



Smart Integrated

Model TAP17

Catalogue 2026



qdtgood.com



COMPANY PROFILE

- Founded in 2004, TGOOD (Stock Code: 300001) was the first company listed on the Growth Enterprise Board of the Shenzhen Stock Exchange in 2009.
- The mission of TGOOD is to create the world's top brand of prefabricated power equipment
- TGOOD's intelligent modular prefabricated substations has occupied a 60% share of power grid and new energy markets.
- TGOOD has delivered product solutions to 6300+ customers, and provided 11,000+ prefabricated substations.
- TGOOD's prefabricated and integrated solutions have been implemented in 50+ countries and regions worldwide.

- ▶ **No.1** The world's No.1 brand of prefabricated substation equipment
- ▶ **The largest in World** One of the largest supplier for prefabricated substation
- ▶ **The largest in China** TGOOD is the largest R&D and production base for prefabricated substations in China
- ▶ **Only in China** The only manufacturer in China achieving digital, technological, specialized, and large-scale production of prefabricated substation.
- ▶ **Champion** MIIT manufacturing industry single item champion enterprise

Four Main Manufacture Factories



Sichuan Chengdu Manufacturing Factory



Hubei Yichang Manufacturing Factory

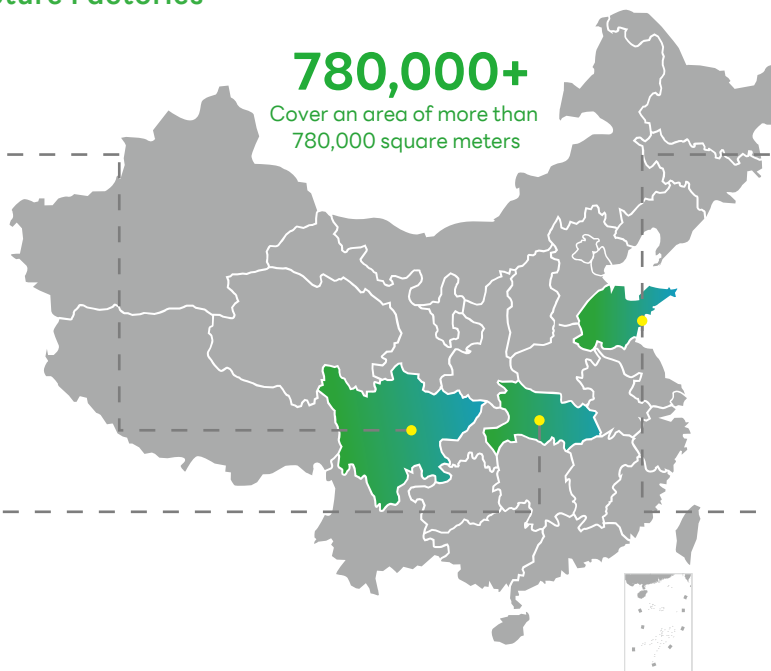

Qingdao West Coast Manufacturing Factory

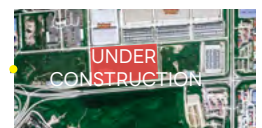

Qingdao Free Trade Zone (China)

Model TAP17

| Application Scenarios



Table of Contents

Company Profile	2
Products	4
Safety	5
Electrical Data	6
Technical Data	7
Installation of Switchgear	8
Recommended Scheme	9
Description	9
Typical Switchgear Layout	9
Cubicle Description	11
IF Incomer and Feeder	11
ID Incomer Direct to Busbar	12
BC Bus Coupler	13
RF Bus Riser Fixed	14
VT Busbar Voltage Transformer	15
RW Bus Riser Withdrawable	16
Panel Design	17
Components	27
Current Transformer	27
Circuit Breaker	29
Transport and Installation	35



Model TAP17

Model TAP17 is a factory-assembled, type-tested, metal-enclosed, gas Insulated indoor switchgear. It is designed as a withdrawable switchgear with a single busbar system. The withdrawable circuit breaker is a vacuum circuit breaker.

- Rated voltage up to 17.5 kV
- Feeder current up to 3150A
- Busbar current of 4000A



Quick-Release
Sliding Door Lock



Independent Compartment
Functional Unit



Logical Mechanical
Interlock Functional Unit

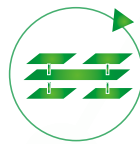

Special Independent
Instrument Box Structure



Flexible Combination
Solutions of Cabinets with
Different Functions

Typical Applications

TAP17 switchgear can be used in a variety of primary distribution systems, such as:

- ▶ **Core scenarios in power systems, for example:**
 - Substations, power plants
 - Power system and utility distribution stations
 - Switching stations, mobile power supply stations and substations
- ▶ **Industrial sectors, for example:**
 - Automotive industry and petroleum industry
 - Step-up substation of photovoltaic and wind power plant
 - Chemical industry and metallurgical industry
- ▶ **Rail transport, for example:**
 - Power supply systems for subways
 - Power supply for high-speed rail and airport
- ▶ **Special industry sectors, for example:**
 - Data centers
 - Port terminals

Technology

- Flexible combination solutions of cabinets with different functions
- Upward relief of gas pressure
- Removable vacuum circuit breakers for circuit units
- Interlocking/mis-operation-proofing protection
- Special structure of independent instrument boxes
- Independent functional compartment units
- Convenient structure of quick-release multi-point door lock
- Cold shrinkable terminals of cable connection
- Single-core cable adaptable to a cross-sectional area of 630 mm²
- Three-core cable adaptable to a cross-sectional area of 300mm²
- Customizable copper busbar and solid insulated busbar connection



Personal Safety

- Enclosure is safe to touch when the panel interior is earthed.
- The maintenance of the cable connection compartment is permitted only when the feeder is earthed.
- Operation can be performed only when the switchgear door is closed
- Logical mechanical interlocks prevent mis-operation
- A voltage indicator is used to check safe isolation from the power supply
- Feeder-side earthing is achieved through a fast earthing switch
- Each high-voltage compartment can be equipped with a channel for releasing arc pressure to the top.



Operation Safety

The high-voltage part of the panel is completely partitioned by different compartments, and these compartments comply with the LSC2B (Loss of Service Continuity Category/Type) as defined in IEC 62271-200.

- Configurable protection, monitoring, and control systems
- Logical mechanical interlock prevents mis-operation
- Mechanical interlock operating holes are equipped with locks to prevent unauthorized access by non-professional personnel



Maintenance and Service

- When not in use, the product should be stored in a dry environment, shielded from light and rain, with a temperature range of -25 °C to +55 °C.
- Real-time support is provided for daily operations: maintenance contracts, technical assistance, spare parts supply, corrective and preventive maintenance, and operation and maintenance training.
- Installation-related service provided:
 - Installation environment analysis
 - Switchgear diagnosis, adaptation, and modification service



Reliability, Service Life, Quality and Environment

- Strict type test and routine test
- Standardized and rigorous CNC production processes
- Quality and environmental management systems according to ISO 9001 and ISO 18001.
- Under normal operating conditions, the expected service life of TAP17 gas Insulated switchgear is at least 20 years, taking the switchgear operation and indoor environment into account

Electrical Data - Switchgear

Name	Unit	1250A	3150A	4000A ₍₁₎	
Rated voltage	kV	17.5	17.5	17.5	
Rated frequency	Hz	50/60	50/60	50/60	
Rated short-timepower frequency withstand voltage	Phase-to-phase, phase-to-earth	kV	38	38	38
	Isolating distance	kV	45	45	45
Rated lightning impulse withstand voltage	Phase-to-phase, phase-to-earth	kV	95	95	95
	Isolating distance	kV	95	95	95
Rated continuous current	A	1250	3150	4000	
Rated short-time withstand current	kA	31.5	31.5	40	
Rated duration of short-circuit	s	3	3	3	
Rated peak withstand current	kA	80/82	80/82	100/104	
Rated short-circuit breaking current	kA	31.5	31.5	40	
Rated short-circuit withstand current of the earthing circuit	kA	31.5	31.5	40	
Rated peak withstand current of the earthing circuit	kA	31.5	31.5	40	
Rated duration of short-circuit of the earthing circuit	s	1	1	1	
Degree of protection	Panel enclosure		IP4X		
	Compartments		IP2X		
Partition class			PM		
Loss of service continuity category			LSC2B		
IAC class			AFLR		
Arc fault current	kA	31.5	31.5	40	
Arc fault duration	s	1	1	1	
Ambient temperature			-5°C/-20°C ₍₂₎ ~+40°C		
Dimensions (height * width * depth) (including arcing channel)	mm	2300*650/ 800*1560	2300*1000*1560	2300*1000*1560	
Standard compliance			IEC 62271-200		

(1) Forced air cooling solution may be customized based on actual rated current requirements.

(2) Forced heating solution may be customized for low-temperature operating environments.

Electrical Data - Circuit Breaker

Name	Unit	1250A	3150A	4000A ₍₁₎	
Rated voltage	kV	17.5	17.5	17.5	
Rated frequency	Hz	50/60	50/60	50/60	
Rated short-timepower frequency withstand voltage	Phase-to-phase, phase-to-earth	kV	38	38	38
	Isolating distance	kV	45	45	45
Rated lightning impulse withstand voltage	Phase-to-phase, phase-to-earth	kV	95	95	95
	Isolating distance	kV	95	95	95
Rated continuous current	A	1250	3150	4000	
Rated short-time withstand current	kA	31.5	31.5	40	
Rated duration of short-circuit	s	3	3	3	
Rated peak withstand current	kA	80/82	80/82	100/104	
Rated short-circuit breaking current	kA	31.5	31.5	40	
Rated short-circuit making current	kA	80/82	80/82	100/104	
DC time constant of rated short-circuit breaking current	ms	45	45	45	
Rated line charging breaking current	A	10	10	10	
Rated cable charging breaking current	A	31.5	31.5	31.5	
Rated operation sequence	O-0.3s-CO-180s-CO				
Class	S1, E2 (list3) C2, M2				
Standard compliance	IEC 62271-100				

(1) Forced air cooling solution may be customized based on actual rated current requirements.



Distribution room layout

Please follow the following distribution room layout and switchgear installation steps:

Installation of Switchgear

Free-standing arrangement (standard)

- 1 row
- 2 rows (face-to-face arrangement)

Option: Wall-standing arrangement

- Switchgear layout dimensions
- Floor openings: For relevant dimensions, see page 25
- Pressure relief direction and related pressure relief space

Pressure relief

According to standard design, pressure is relieved upwards.

Free-standing arrangement of switchgear

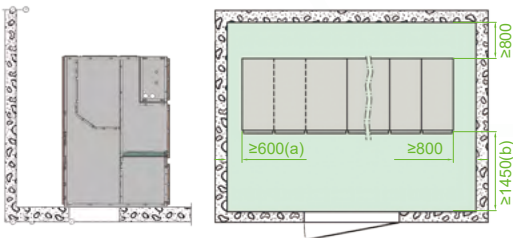

a. For single-row switchgear, the wall-standing arrangement may be chosen in the left space, without considering the maintenance at the top of the switchgear.

b. According to the requirements of the country of installation, and considering daily operation and maintenance and future expansion needs, it is recommended to have a maintenance channel of at least 1450 mm wide. For space-constrained products such as vehicle-mounted mobile substations, the space can be appropriately reduced based on needs.

Free-standing arrangement of switchgear

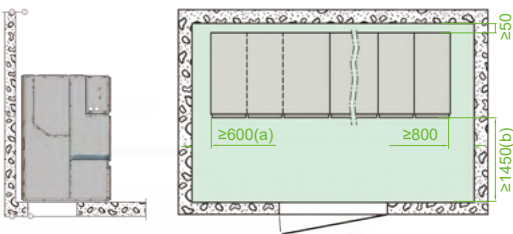

a. For single-row switchgear, the wall-standing arrangement may be chosen in the left space, without considering the maintenance at the top of the switchgear.

b. According to the requirements of the country of installation, and considering daily operation and maintenance and future expansion needs, it is recommended to have a maintenance channel of at least 1450 mm wide. For space-constrained products such as vehicle-mounted mobile substations, the space can be appropriately reduced based on needs.

Installation of Switchgear

Pressure Relief Methods

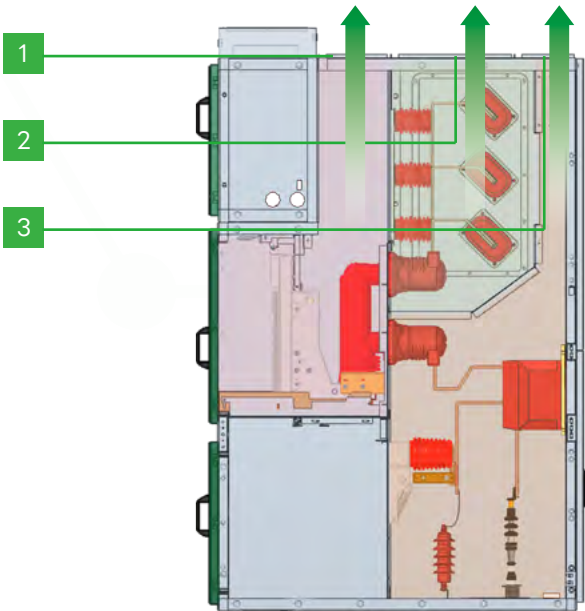

- 1 Arcing pressure relief path in the switching-device compartment
- 2 Arcing pressure relief path in the busbar compartment
- 3 Arcing pressure relief path in the cable connection compartment

Switchgear pressure relieved directly upwards to its top



Option: switchgear pressure relieved to the outside through the top arc fault channel

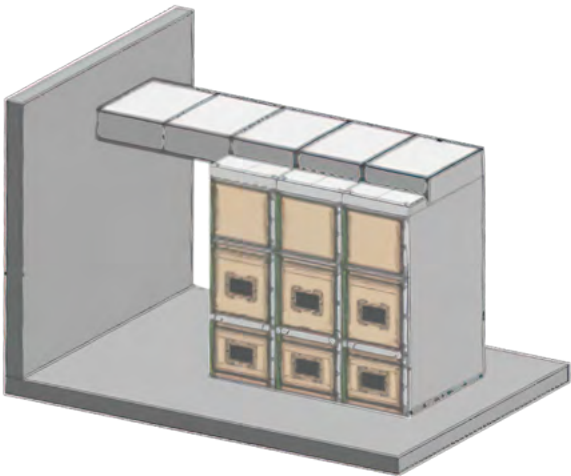







Recommended Scheme

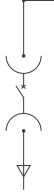

Description

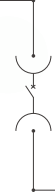
TAP17 series includes 6 functional applications.

The table below can be used to link the requirements with the functional units and provide basic information about the general composition of each unit.

Function	Connection to incomer or feeder lines	Direct connection of supply to busbar	Coupling of two busbars systems
Name	IF Incomer and Feeder	ID Incomer Direct to busbar	BC Bus Coupler
Single Line Diagram			
Function	Solid busbar link to be used in association with a BC unit	Busbar link to disconnector in association with a BC unit	Connect VT to the busbar for metering
Name	RF Bus Riser- Fixed type	RW Busbar Riser- Withdrawable	VT Busbar Voltage Transformer
Single Line Diagram			



Typical Switchgear Layout (Example)

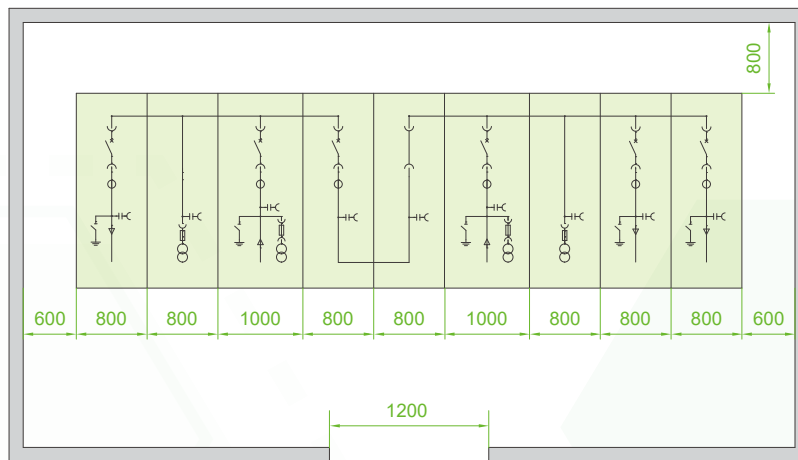

Cubicle Description



IF Incomer and Feeder

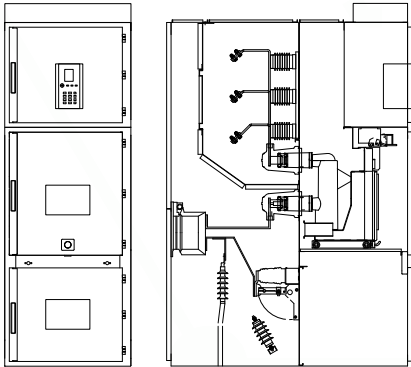

Rated voltage(kV)		12			17.5	
Rated insulation level						
Power frequency withstand voltage 50/60 Hz- 1min (rms kV)		28			38	
Lightning impulse withstand voltage 1.2/50µs (kV peak)		75			95	
Rated current (A)	630	<input checked="" type="checkbox"/>	<input checked="" type="checkbox"/>		<input checked="" type="checkbox"/>	
	1250	<input checked="" type="checkbox"/>	<input checked="" type="checkbox"/>		<input checked="" type="checkbox"/>	
	3150			<input checked="" type="checkbox"/>		<input checked="" type="checkbox"/>
	4000			<input checked="" type="checkbox"/>		<input checked="" type="checkbox"/>
Breaking capacity (kA)	25	<input checked="" type="checkbox"/>	<input checked="" type="checkbox"/>		<input checked="" type="checkbox"/>	
	31.5	<input checked="" type="checkbox"/>	<input checked="" type="checkbox"/>	<input checked="" type="checkbox"/>	<input checked="" type="checkbox"/>	<input checked="" type="checkbox"/>
	40			<input checked="" type="checkbox"/>		<input checked="" type="checkbox"/>
Short-time withstand current (kA/3s)	25	<input checked="" type="checkbox"/>	<input checked="" type="checkbox"/>		<input checked="" type="checkbox"/>	
	31.5	<input checked="" type="checkbox"/>	<input checked="" type="checkbox"/>	<input checked="" type="checkbox"/>	<input checked="" type="checkbox"/>	<input checked="" type="checkbox"/>
	40			<input checked="" type="checkbox"/>		<input checked="" type="checkbox"/>
Dimensions (mm)						
Width (W)		650	800	1000	800	1000
Height (H)		2300				
Depth (D)	top entry	1910				
	bottom entry	1500				



Function

- Low voltage cabinet standard height
- Circuit-breaker TCB range - vacuum technology TCB
- Voltage transformers
- fused withdrawable fused fixed fixed without fuses
- Earthing switch
- Voltage Presence Indication System (VPIS)
- MV cables connection bottom entry top entry
- Current transformers
- 3 MV type 6 MV type 3 MV low powered CTs (up to 1250 A)
- LV toroidal CTs on MV primary bar (up to 1250 A)
- Surge arresters
- Anti condensation heaters

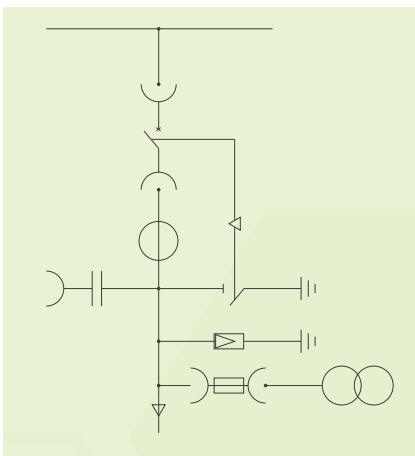

Cubicle Description

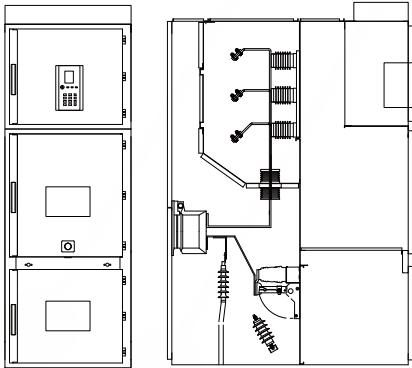

ID Incomer Direct to Busbar

Rated voltage(kV)		12		17.5		
Rated insulation level						
Power frequency withstand voltage 50/60 Hz- 1min (rms kV)		28		38		
Lightning impulse withstand voltage 1.2/50µs (kV peak)		75		95		
Rated current (A)	1250	■	■	■	■	
	3150			■	■	
	4000			■	■	
Short-time withstand current (kA/3s)	25	■	■	■	■	
	31.5	■	■	■	■	
	40			■	■	
Dimensions (mm)						
Width (W)		650	800	1000	800	1000
Height (H)		2300				
Depth (D)	top entry	N/A				
	bottom entry	1500				



Function

- Low voltage cabinet
- standard height
- Voltage transformers
- fused withdrawable fused fixed fixed without fuses
- Earthing switch
- Voltage Presence Indication System (VPIS)
- MV cables connection bottom entry top entry
- Current transformers
- 3 MV type 6 MV type
- 3 MV low powered CTs (up to 1250 A)
- LV toroidal CTs on MV primary bar (up to 1250 A)
- Surge arresters
- Anti condensation heaters

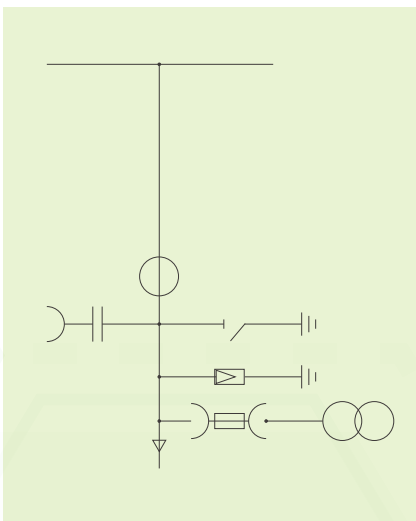

Cubicle Description



BC Bus Coupler

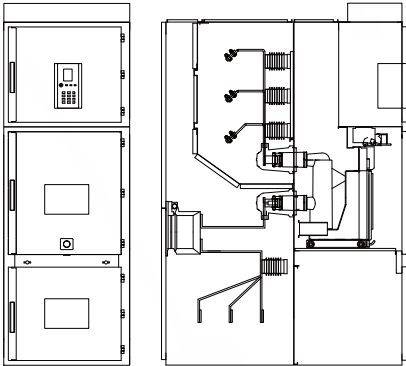

Rated voltage(kV)		12		17.5	
Rated insulation level					
Power frequency withstand voltage 50/60 Hz- 1min (rms kV)		28		38	
Lightning impulse withstand voltage 1.2/50µs (kV peak)		75		95	
Rated current (A)	1250	■		■	
	3150	■	■	■	■
	4000		■		■
Short-time withstand current (kA/3s)	25	■		■	
	31.5	■	■	■	■
	40		■		■
Dimensions (mm)					
Width (W)		800	1000	800	1000
Height (H)		2300			
Depth (D)		1500			



Function

- Low voltage cabinet
- standard height
- Circuit-breaker
- TCB range - vacuum technology TCB
- Earthing switch
- Voltage Presence Indication System (VPIS)
- Current transformers
- 3 MV type
- 6 MV type
- 3 MV low powered CTs (up to 1250 A)
- Surge arresters
- Anti condensation heaters

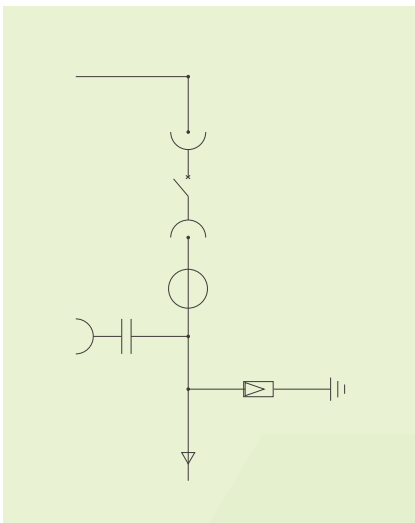

Cubicle Description

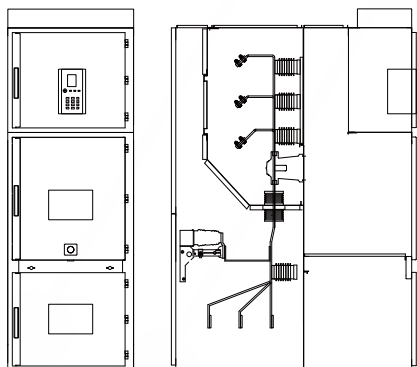

RF Bus Riser Fixed

Rated voltage(kV)		12		17.5		
Rated insulation level						
Power frequency withstand voltage 50/60 Hz- 1min (rms kV)		28		38		
Lightning impulse withstand voltage 1.2/50µs (kV peak)		75		95		
Rated current (A)	1250	■	■	■		
	3150			■	■	
	4000			■	■	
Short-time withstand current (kA/3s)	25	■		■		
	31.5	■	■	■	■	
	40			■	■	
Dimensions (mm)						
Width (W)		650	800	1000	800	1000
Height (H)		2300				
Depth (D)		1500				

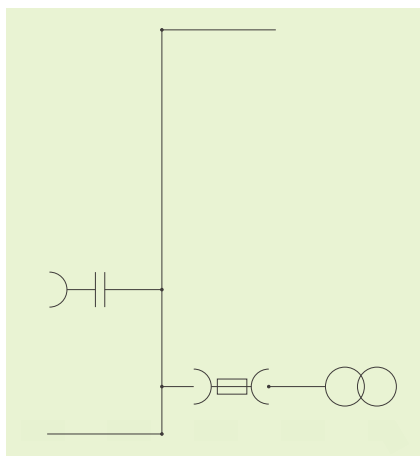

Function

- Low voltage cabinet
- standard height
- Voltage transformers
- fused withdrawable
- fused fixed
- fixed without fuses
- Anti condensation heaters

Cubicle Description



VT Busbar Voltage Transformer

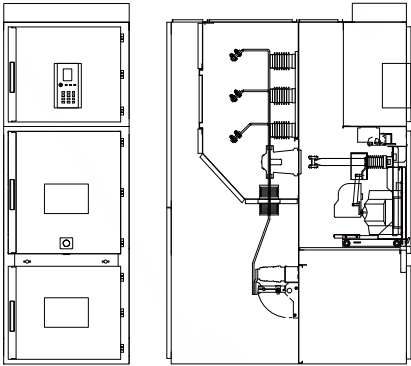

Rated voltage(kV)		12	17.5		
Rated insulation level					
Power frequency withstand voltage 50/60 Hz- 1min (rms kV)		28	38		
Lightning impulse withstand voltage 1.2/50µs (kV peak)		75	95		
Short-time withstand current (kA/3s)	25	■	■	■	
	31.5	■	■	■	
Dimensions (mm)					
Width (W)		800	1000	800	1000
Height (H)		2300			
Depth (D)		1500			



Function

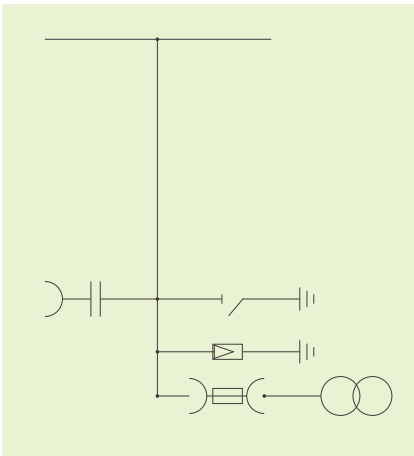

- Low voltage cabinet
- standard height
- Voltage transformers
- fused withdrawable
- fused fixed
- fixed without fuses
- Earthing switch
- Voltage Presence Indication System (VPIS)
- Surge arresters
- Anti condensation heaters

Cubicle Description

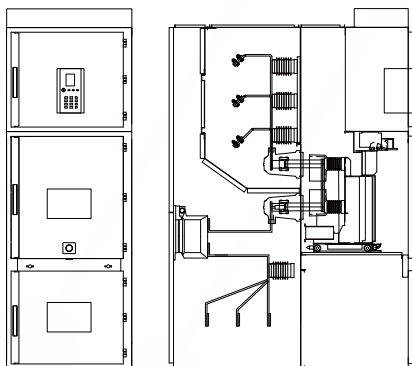

RW Bus Riser Withdrawable

Rated voltage(kV)	12		17.5		
Rated insulation level					
Power frequency withstand voltage 50/60 Hz- 1min (rms kV)	28		38		
Lightning impulse withstand voltage 1.2/50µs (kV peak)	75		95		
Rated current (A)	1250	■	■	■	■
	3150			■	■
	4000			■	■
Short-time withstand current (kA/3s)	25	■	■	■	■
	31.5	■	■	■	■
	40			■	■
Dimensions (mm)					
Width (W)	650	800	1000	800	1000
Height (H)	2300				
Depth (D)	1500				



Function

- Low voltage cabinet
- standard height
- Disconnector truck
- Earthing switch (optional)
- Voltage Presence Indication System (VPIS)
- Optional accessories
- Motor for operating mechanism
- Auxiliary contacts
- Key-type interlocks
- Anti condensation heaters

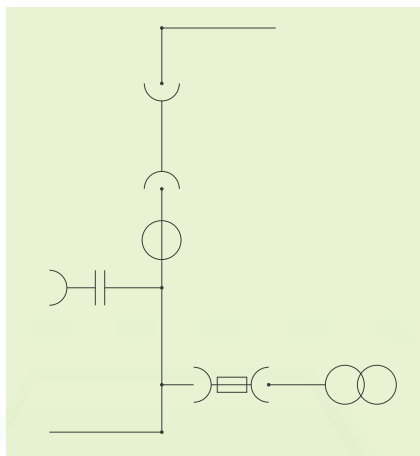



Basic Structure

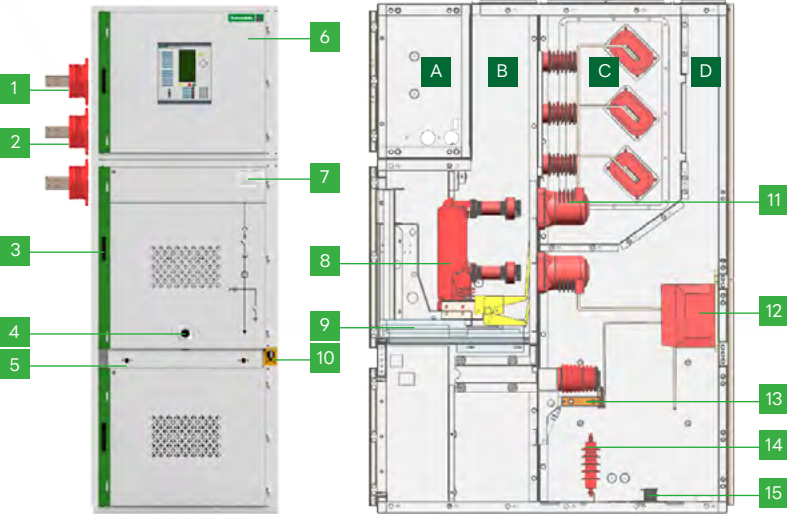

- 1 Busbar
- 2 Busbar insulation bushing
- 3 Door handle
- 4 Switching-device in/out entrance
- 5 Positioning holes for maintenance and transfer trolley
- 6 Low-voltage compartment door
- 7 Nameplate
- 8 Switching-device circuit breaker
- 9 Rails
- 10 Operation openings for earthing switch
- 11 Contact box
- 12 Current transformer
- 13 Earthing switch
- 14 Surge arrester
- 15 Cable clip

- A The switchgear is divided into 4 compartments: A Low Voltage (LV) Compartment
- B Circuit Breaker Compartment
- C Busbar Compartment
- D Cable Connection Compartment

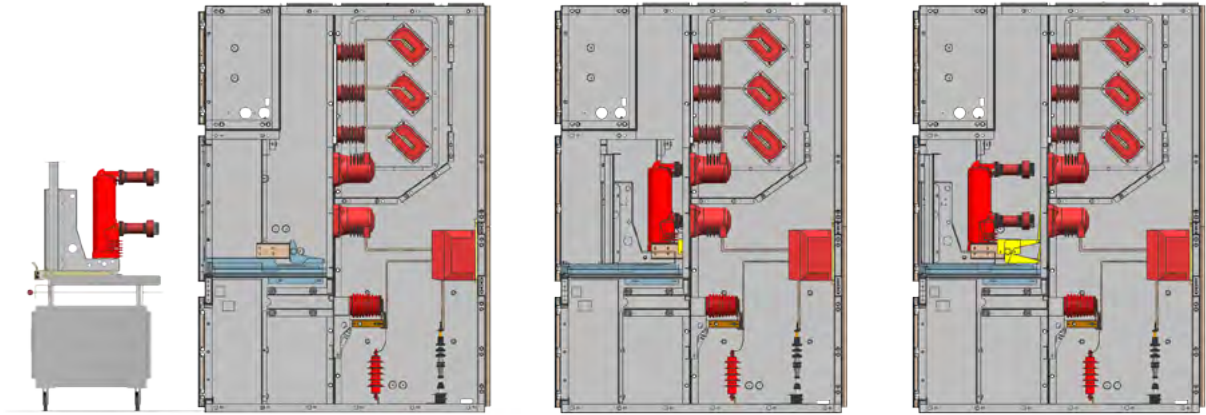

External Transfer of Switching Device (Example)

Test Position (Example)

Service Position (Example)

Panel Design



Low-voltage Compartment
(Example)



Low-voltage compartment

This compartment includes all low-voltage equipment, such as fuses, miniature circuit breakers, control terminals, protective relays, indicator lights/instruments, push buttons, relays, and control switches, which are installed on the low-voltage compartment door and inside the low-voltage compartment.



Busbar compartment

The busbar is made of copper bars and laid in sections from the end switchgear. Depending on the rated current, single-layer (1250A), double-layer (3150A), or triple-layer (4000A) configurations are used.

TAP17 busbars are fixed by busbar bushing. No special clips are required.

Busbars are insulated using heat-shrinkable sleeve. The bolt connection points in the busbar system are encapsulated by insulating covers, so there are no arc fault points along the entire busbar.

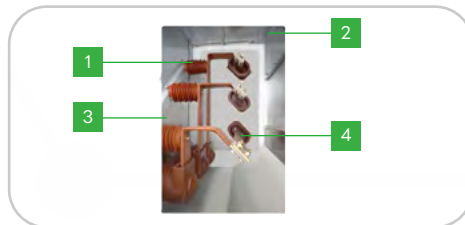

View of Busbar Compartment (Example)

- 1 Busbar heat-shrinkable sleeve
- 2 Pressure relief flap
- 3 Intermediate partition
- 4 Busbar bushing mounting plate



Circuit breaker compartment

The circuit breaker compartment contains the movable circuit breaker equipment and all necessary components to work with it. Like the busbar compartment, all sides are separated by metal partitions.



Circuit Breaker Compartment Shutter (Example)

- 1 Shutter baffle
- 2 Contact box mounting plate
- 3 Contact box

Circuit Breaker Compartment (Example)

- 4 Low-voltage control wiring socket
- 5 Low-voltage control cable trough cover plate
- 6 Earthing contact
- 7 Aviation plug interlock

Cable connection compartment

The cable connection compartment contains current transformers and earthing switches. Depending on the user's requirements, surge arresters can be optionally installed.

Three current transformers are designed to be installed at the rear of the cable connection compartment.

The earthing switch is mounted on the partition in the middle of the cable connection compartment. The earthing switch can be optionally equipped with manual or electric operating mechanisms. The open/close status can be indicated by mechanical and electrical auxiliary switches.

The mechanical indicator located in the partition and faces forward, so it can be observed through the observation window on the lower door at the front of the switchgear.

This switchgear can be connected up to six parallel cables. Customized designs can be provided for busbar connection methods, special cables, or sealed terminal types based on customer requirements.

Three sets of surge arresters can be fixed below the earthing switch, and a withdrawable structure can also be adopted in specific designs.

Low-voltage control cables are laid in cable troughs covered with metal plates, which can protect the low-voltage cables in the event of an arc fault.

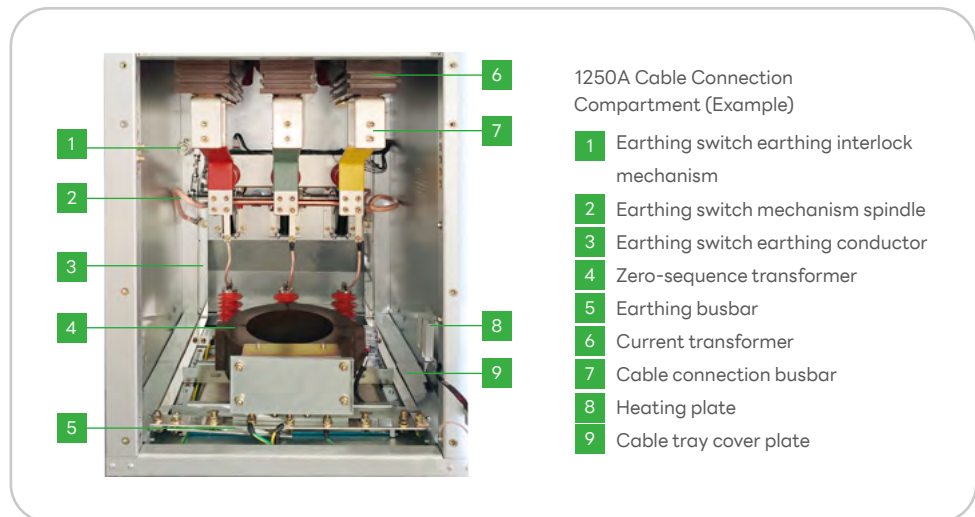

Panel Design



Base Interface

The switchgear should be primarily installed on an embedded base structure that must be levelled with the floor surface of the power distribution room.

If a bracket-lifted plate structure is used for installation, the following conditions must be met:

The maximum height deviation between the front bracket of the switchgear and the floor surface of the power distribution room should be ≤ 10 mm (based on dimensional tolerance standards stated in EN 10034); and the mechanical latch of the maintenance trolley must engage effectively with the switchgear (functional verification requirement).

An example of the typical switchgear foundation is shown below:

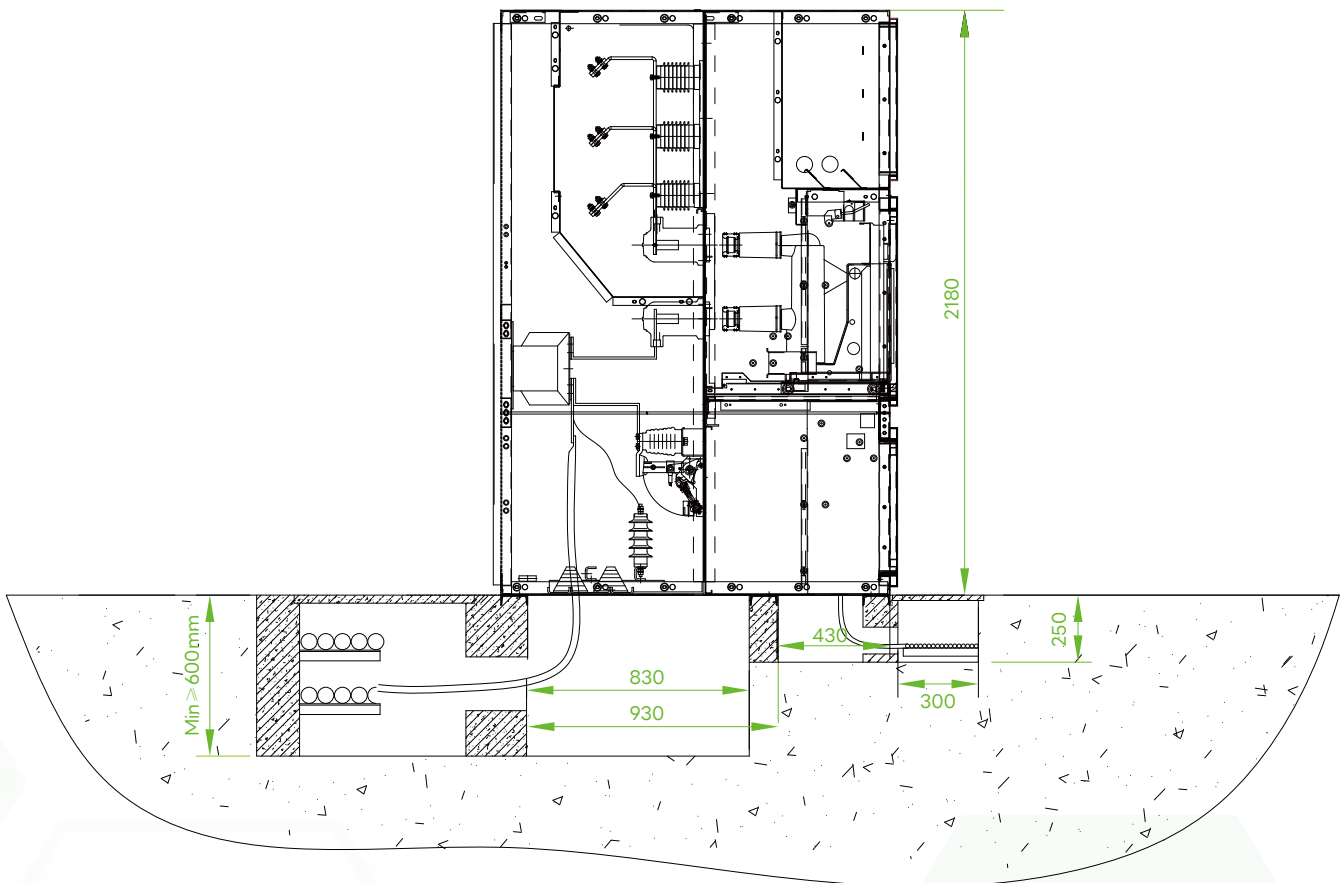

Foundation structure view - including the foundation frame on the concrete base plate



Base Interface

There are several conventional foundation installation methods for switchgear:

Installation Method A – installation on steel-reinforced concrete with foundation rails

Due to the size differences of switchgear, the steel-reinforced concrete with foundation rails may consist of one or more sections. The installation on steel-reinforced concrete with foundation rails is usually carried out by on-site structure personnel.

It is recommended that, when possible, the installation process should be supervised by TGOOD technical experts (to meet the manufacturer's quality control requirements).

Installation Method B – installation on concrete slabs

When the switchgear is installed directly on a horizontal concrete floor, the requirements for floor flatness are significantly increased. With this mounting type, the floor flatness tolerance must align with the installation tolerance for the steel-reinforced concrete with foundation rails specified in Method A.

Installation Method C – installation on bracket lifted plate

The switchgear is fixed by welding its outer side boards to a steel plate frame (implemented when the frame dimensions exceed the switchgear base area, i.e., welding along the outer walls). This mounting method is not recommended if seismic resistance is required.

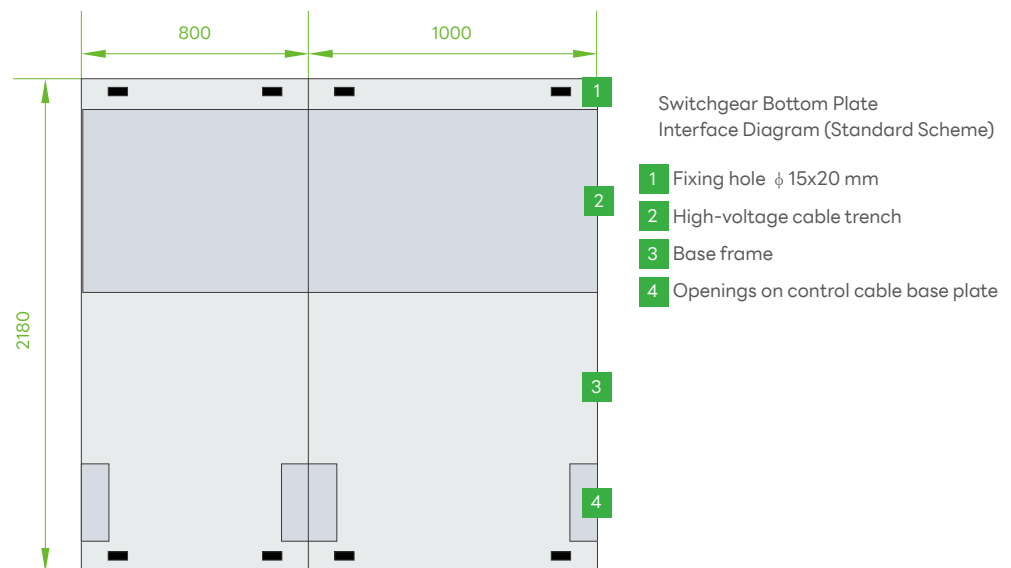

Panel Design



Foundation Installation Solution

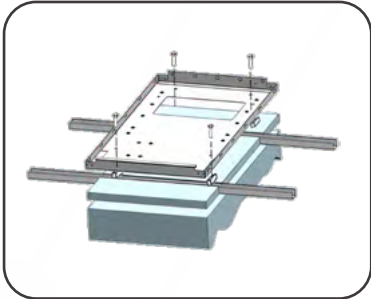

Installation Method A – installation on steel-reinforced concrete with foundation rails

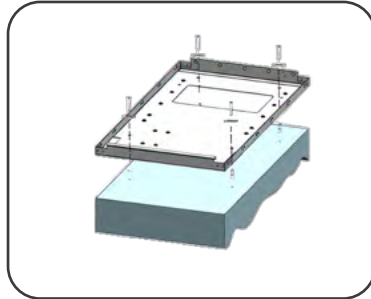

Installation Method B – installation on concrete slabs

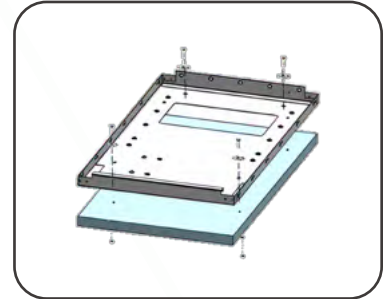

Installation Method C – installation on bracket lifted plate



Combined Switchgears and Components Installation of wall bushing

The wall bushing for switchgear busbars is a removable structure
The accessory bushing must be installed onto the panel before switchgear combination

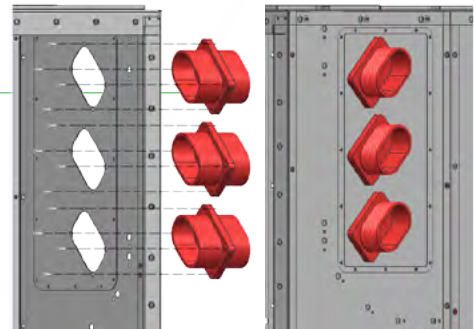

The wall bushing must be fixed before switchgear combination



Combination of switchgear

When installing TAP17 switchgear locally, the accessories are equipped with bolts of tensile strength grade 8.8.
The recommended nominal fastening torque values are provided in the table, and these torque values are also applicable to bolts of other tensile strength grades.
It is recommended to lightly apply oil or lubrication to the threads and head contact surfaces of the bolts to ensure accurate application of the nominal tightening torque



View of Side Fastening Point Location of Switchgear

Bolt Specification	M8	M10	M12	M14	M16	M18	M20	M24
Torque value N•m	8.8~10.8	17.7~22.6	31.4~39.2	51.0~60.8	78.5~98.1	98.0~127.4	156.9~196.2	274.6~343.2

Tightening Torque Value for Connecting Bolts of Deflector Components

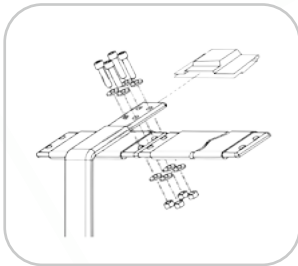

Single-branch busbar overlapping with single-layer busbar

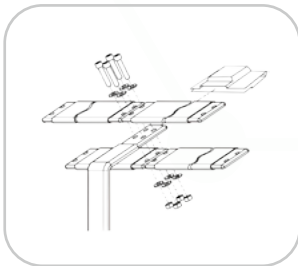

Single-layer branch busbar overlapping with double-layer busbar

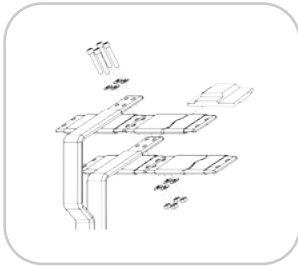

Double-layer branch busbar overlapping with double-layer busbar



Busbar installation

Busbar installation

When installed, busbars can be accessed via removal of the pressure relief plate above the panel.

If you need to access the busbar from the circuit breaker compartment, first remove the circuit breaker, then remove the vertical partition.

After completing the above steps, follow the procedures below:

- Use a soft dry cloth to clean the busbar insulation layer, check for insulation damage, and remove grease or attached dirt.
- Connect the busbar
- Clean the silver-plated surfaces at the connection points with a non-metallic non-woven cleaning cloth
- Prepare insulation bushing according to the corresponding busbar connection specifications and insert them into the busbar.
- Install the busbars on the panel one by one according to the switchgear sequence. Align the busbar components vertically according to the system layout and secure them along the direction of the flat branch conductors using the provided hex screws (operate according to the specified tightening torque).
- Cover the bolted connection points at the overlapping surfaces with insulating sleeves.

Notes: It is recommended to inspect the tightness of busbar connections only during maintenance periods.



Structure and installation of arcing pressure relief plates

High-voltage compartment pressure relief method:

The cover plate is fixed to one side of the switchgear with metal screws (2), and the other side is fixed with nylon screws (1). If a fault occurs inside the high-voltage compartment, the internal pressure will be relieved along the path of least resistance, causing the screws to break and the cover plate to open, thereby venting the high-pressure gas.

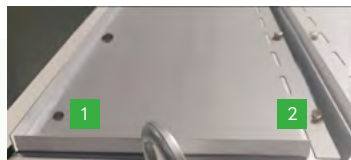

Top View of the Pressure Relief from the Cover Plate of Switchgear

- 1 Nylon bolts used to fix the pressure relief plate to the switchgear and break during an arc fault
- 2 Metal bolts used to secure the pressure relief cover plate to the switchgear

Panel Design



Options and Standards for Arcing Pressure Relief Channel

- a. Classification without Arc Fault
- b. Classification of Arc Protection Level for Arc Deflector
- c. Classification of Arc Protection Level for Pressure Relief Channels

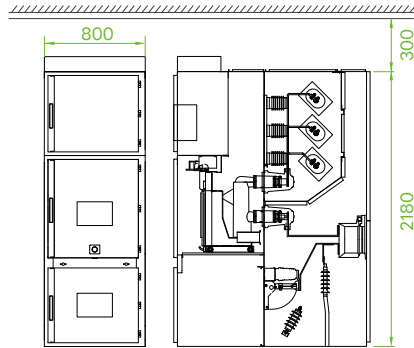

Classification without Arc Fault (Standard)

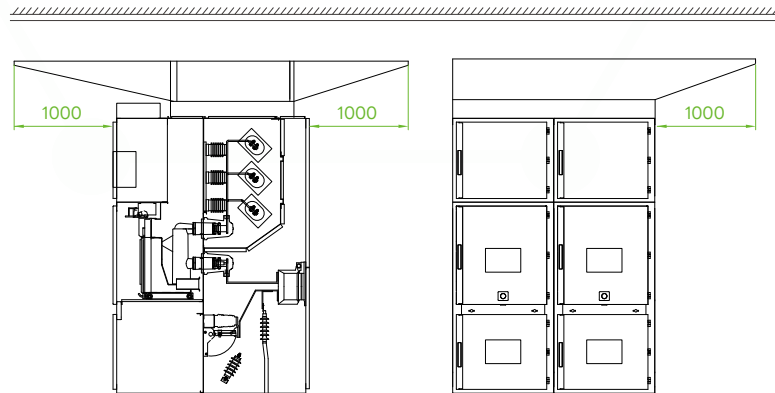

Classification of Arc Deflector Fault

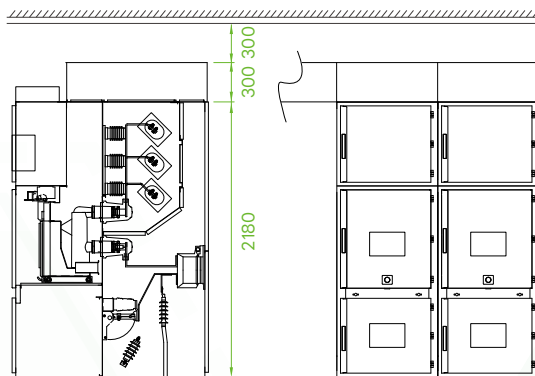

Classification of Arc Channel Faults

Power Cables



Rear View of Connection of Single Cable and Busbar in Switchgear

The power cable enters the switchgear cable connection compartment through the foundation from below, and passes through a rubber reducer ring (the reducer ring can be adjusted to fit the cable diameter).

Cable terminations must be installed to the cable core as per the manufacturer's instructions. Different brands of cable terminations (e.g., Pirelli, Raychem, etc.) may be selected, but the total length of the cable end (including the terminals) must meet the spacing requirements between the cable connection busbar and the switchgear base plate.

The connection busbar is equipped with M12 screw mounting holes. In the standard scheme, the cable shield earthing wire is connected to the earthing busbar near the cable clip, which is connected to earth potential.

Important Notes:

Connections inside the switchgear typically adopt single-core silicone-insulated cables. Special cables (such as 3-core cables and special insulation cables) must be confirmed through consultation between the customer and the manufacturer.



Power Cable Installation Process



Side View of Dual Cable Busbar Connection in Switchgear

- The power cable must first pass into the switchgear, then be cut to length and stripped of insulation.
- The rubber reducer ring must be adjusted according to the cable diameter before being inserted into the cable.
- The cable termination must be processed and installed to the cable core according to the manufacturer's instructions.
- The cable termination must be connected to the pre-fabricated connection busbar via pressure relief devices.
- Each cable must be correctly earthed.
- Cable sealing covers must be mounted for segmented base plates.
- The reducer ring must be moved downward so that it fits into the corresponding groove in the base sealing plate, to seal the cable channel.
- The cable must be fixed with pre-fabricated cable clips.

Cable Connection Design

Low-voltage Control Cable (entry from bottom)

- The low voltage control cable must pass into the left cable trough inside the switchgear and be laid upward along the internal cable trough.
- To facilitate cable entry, the left and right sides of the switchgear bottom remain open.
- The cables are fully protected by a metal cable trough, which extends along the interior of the panel to the low-voltage compartment. Both sides are enclosed by metal plates, isolating them from other areas of the panel.
- The cable troughs on the front left/right sides of the low-voltage compartment's base plate route the secondary wiring from inside/ outside the switchgear to the low-voltage compartment
- The low-voltage control cables must be stripped and fixed at the top of the cable trough, with the conductors connected to the terminals in the low-voltage compartment
- Control cables are connected to the terminal blocks according to the wiring diagram
- Control circuits are electrically connected to adjacent switchgears through cable entry holes covered by flanges on the left and right sides of the switchgear.

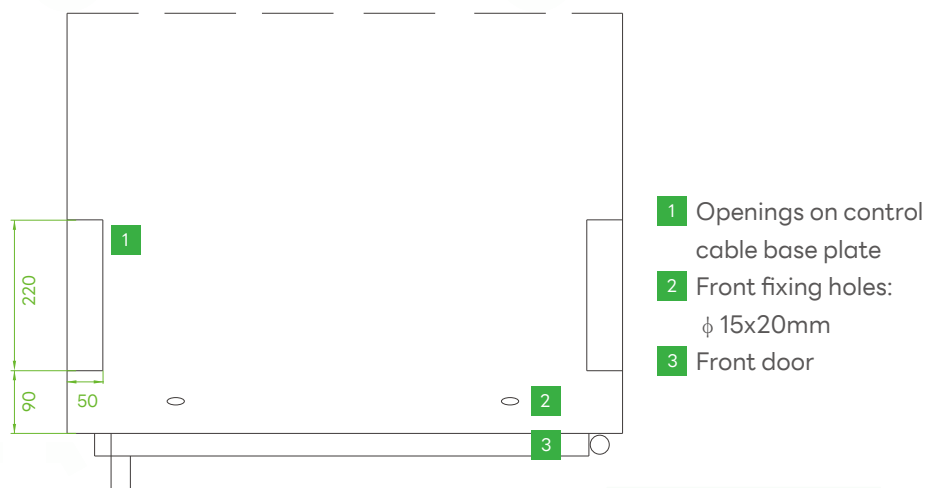

Top-Down View of Base Plate of Low-Voltage Control Cable Trough



I _{ln} (A)	10-400	<400-3150
I _{th} (kA)	25	31.5/40
t (s)	1	3
Accuracy class	5P/0.5/0.2S	



Current Transformer

The conventional current transformer is used to provide current input for metering, measurement, or protection and controlling devices, capable of measuring primary currents from 10A to 4000A, in compliance with IEC 61869-2.

To facilitate the matching of accuracy characteristics, TGOOD has compiled a list for model selection of current transformers suitable for digital protection devices.

The transformer is installed at the rear of the functional compartments, and the live parts are encapsulated with epoxy resin, offering both electrical insulation and high mechanical strength.

The transformer exhibits linear response characteristics over a wide current range and enters saturation only after exceeding the breaking current.

Core data include:

- Rated primary current
- Extended primary current
- Accuracy-class primary current (or ALF accuracy limit factor)



I _{ln} (A)	<3150-4000
I _{th} (kA)	31.5/40
t (s)	3
Accuracy class	5P/0.5/0.2S



Zero Sequence Core Balance Current Transformer

This transformer achieves more sensitive protection functions by directly measuring the earthing fault currents. This type of transformer is specifically designed for particular relays and can be directly connected to the “residual current” input port.

The model differences are only reflected in the inner diameter specifications:

- Model 120 – inner diameter 120 mm
- Model 200 – inner diameter 200 mm



Voltage Transformer

A voltage transformer is a device used to transform the voltage on a line or busbar, primarily to reduce high voltage to a low voltage suitable for measurement and protection.

It is widely used in power systems to measure line voltage, power, and electrical energy, protect valuable equipment, motors, and transformers in the line, and provide electrical isolation with the medium-voltage (MV) section. Its design complies with IEC 61869-3.

TGOOD has compiled a list for model selection of voltage transformers suitable for digital protection devices.

Such transformers are installed at the bottom of functional compartments, and live parts are encapsulated with epoxy resin, providing reliable electrical insulation performance and excellent mechanical strength.



Components



Voltage Presence Indication System (VPIS)

VPIS works in conjunction with contact-type capacitive high-voltage sensors in the primary circuit to display the live status of each phase of the main circuit in the form of light.

In addition to display and voltage verification functions, the voltage indicator provides contact into the magnetic lock control circuit to lock earthing switches or doors.

This voltage indicator is installed on the door panel of the low-voltage compartment, and its voltage coverage range complies with IEC 61958, with five levels in total:

• 1.0~1.9 kV • 2.0~3.0 kV • 3.1~5.9 kV • 6.0~8.9 kV • 9.0~17.9 kV



Secondary Components

Power monitoring and control devices

This power meter is an economical and efficient high-performance instrument that can operate as an independent device or be integrated into the power monitoring system (please consult us for details).

Basic monitoring functions:

- Billing class: Current/voltage accuracy 0.2%
- Embedded storage module: For energy consumption analysis
- Embedded clock/calendar: Support for time/data stamping Application flexibility:
- Standalone meter and display module
- Direct connection voltage up to 600V (higher voltage requires a voltage transformer)

Other devices: applicable to devices such as line monitors for medium voltage (MV) and low voltage (LV) networks, with main functions including:

- Comprehensive power monitoring
- Power quality analysis and recording
- Input/output control



Other Components

An example of the TAP17 switchgear standardized component integration solution is as follows:

- Low-voltage circuit breaker: Covering the full current range from 1A to 100A
- Push button
- Turn button switch
- Signal indicator
- Temperature sensor
- Sensors (temperature, humidity, arc, partial discharge)
- Communication unit: Industrial-grade communication box

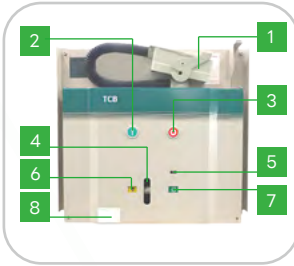

Circuit Breaker Front Panel (Example)

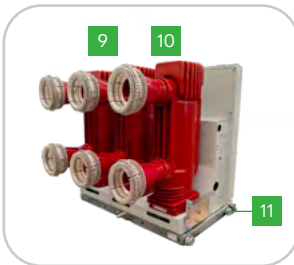

Removable Components of Circuit Breaker (Example)

- 1 Low voltage control circuit plug
- 2 Push button for mechanical closing
- 3 Push button for mechanical opening
- 4 Operating position of energy storage handle
- 5 Mechanical operations counter
- 6 Energy storage status indicator
- 7 Closing/opening status indicator
- 8 Nameplate
- 9 Contact arm
- 10 Star contact
- 11 Chassis cart



TCB Circuit Breaker Performance

The withdrawable circuit breaker forms a complete module, including the TCB-type circuit breaker body, withdrawable component, isolating connection arm with contacts, and control cable connector.

The withdrawable component is electrically connected to the circuit breaker via a multi-core control cable connector and is linked to the panel through a mechanical structure. The fixed side is secured to the panel using plug-in connectors on both sides, while the movable side (including the circuit breaker) can be moved between the service and test positions with the switchgear door closed, through manual or motor-driven screw rods. The auxiliary switch accurately determines the service and test positions and provides real-time feedback of the screw rod's final position and angle.

Withdrawable components of the same specifications are interchangeable. If the component sizes are the same but the circuit breaker configurations differ, the coding design of the control cable connector prevents the connection of mismatched connectors.



Reliability and Stability

The reliability and operational stability of the switchgear are ensured by its internal components, forming a coordinated system architecture among the components. This technology can provide the highest level of power supply continuity assurance for user devices.



Embedded Poles

The TCB vacuum circuit breaker is configured with an embedded pole structure, offering the following technical advantages:

- Adaptability to harsh environments: being suitable for dusty, salty, humid, and high- altitude conditions
- Use of PGA technology: enhancing the mechanical strength of TCB, making it more reliable and meeting the highest Mechanical duration class (IEC 62271-100: Class M2)
- Enhanced insulation performance: significantly improving the continuous operation reliability of the equipment.



Pre-assembled Mechanism

TCB adopts a modular design and pre-assembled spring mechanism, and its outstanding mechanical performance has been verified as follows:

- Mechanical duration: 10,000 Times
- Energy storage power: 120W/120VA

Components



Universal Interfaces

Universal interfaces facilitate replacement, maintenance, and upgrades, including:

- Operation interface: open/close push button, position indicator, switching device operation position
- Installation interface: pole clearance, phase clearance, bottom wheel spacing, push plate position, earthing switch lock interface
- Connection interfaces: Low-voltage plug (including pin numbering and plug dimensions)



TCB Vacuum Circuit Breaker (12kV - 17.5kV)

TCB circuit breakers are applied in protection and control applications for medium-voltage public or industrial distribution grids.

- Rated voltage: 12kV/17.5kV
- Short-circuit breaking capacity: Up to 40kA
- Rated current scope: 630A~4000A
- Core technology: Axial magnetic field (AMF) breaking technology
- Installation type: Withdrawable structure

TCB circuit breakers are compatible with IF and BC switchgear, with a maximum voltage rating of 17.5 kV



High Electrical Duration

A magnetic field is applied along the axis of the contact of the vacuum interrupter, and this technology maintains the arc diffusion mode even under high current values. This process ensures that energy is optimally distributed across the contact surface, preventing partial temperature rise.

Technical advantages

- Compact vacuum interrupter
- Low arc energy loss, TCB meets the highest electrical duration class (IEC 62271-100: Class E2)
- Excellent current switching performance (IEC 62271-100: Class C2)



Energy Storage Mechanism Operation

This mechanism ensures that the device's opening and closing speed is unaffected by the operating mode (electric or manual command). The electric control mechanism performs the re-closing cycle and automatically stores energy via a gear motor after each closing operation.

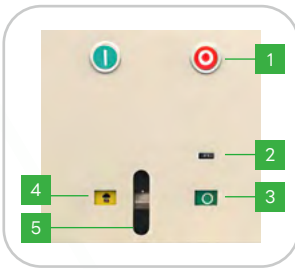

Description of TCB
Circuit Breaker Functions



Composition of Circuit Breaker

This device consists of the following components:

- Energy storage mechanism, which stores the energy required for opening and closing operations via springs
- Provided with an operating rod for manual energy storage (5) (suitable for situations where auxiliary power is unavailable)
- Manually controlled device through a push button (1) on the front panel (test position accessible)
- The remote electric closing device includes a trip-free mechanism with an anti-pumping relay
- The electric opening device includes one or more releases, such as:
 - Shunt release
 - Under-voltage release
- Operations counter (2)
- Breaker open/close status indicator achieved via a mechanical indicator (3)
- Auxiliary contact group: Includes 3 groups of 4-contact modules, adjustable according to the wiring scheme
- Energy storage status indicator (4): Achieved via a mechanical indicator and electrical contacts

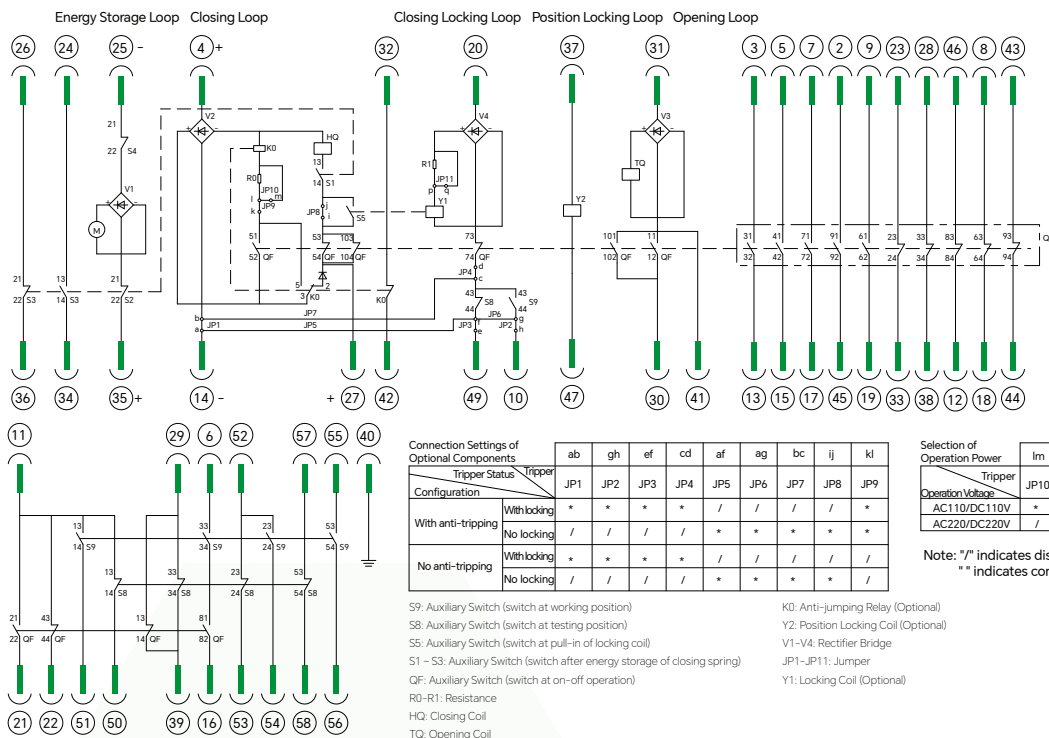

Note: this diagram indicates the opening, non-energy storage, handcart test positions of circuit breaker;
 When the operation power is DC power, the motor shall be connected by diagrammatic polarities.

Components



Withdrawable Component Data: Circuit Breaker

Electrical features comply with IEC 62271-100

Ur 17.5 kV	Isc	Ir			
Clearance width (mm)			800	1000	
Ud 50 kV 50/60 Hz, 1 min Up 125 kV peak	25kA	630A	■		
		1250A	■		
		2500A		■	
	31.5kA	630A	■		
		1250A	■		
		2500A			■
		3150A			■
	40kA	4000A			■
Additional features comply with IEC 62271-100					
Rated values					
Voltage	Ur	kV rms	17.5		
Insulation voltage					
Power frequency withstand voltage	Ud	kV rms	38		
Lightning impulse withstand voltage (1.2/50 μ s)	Up	kV peak	95		
Frequency	fr	Hz	50-60		
Short-time withstand current	Ik/tk	kA	Isc/3s		
Peak withstand current	Ip	kA peak	2.5 Isc (50 Hz)		
			2.6 Isc (60 Hz)		
Short-circuit making capacity		kA peak	2.5 Isc (50 Hz)		
			2.6 Isc (60 Hz)		
Other features					
Operating sequence	O-0.3s-CO-3min-CO				
Closing and opening times	Opening	ms	≤ 50		
	Breaking	ms	≤ 60		
	Closing	ms	≤ 70		
Mechanical duration	Class		M2		
	Operating cycles		10000		
Electrical duration	Class		E2		
Capacitive current breaking capacity	Class		C2		
Operating environment	-5 °C to +40 °C				
Average relative humidity	Over 24 h		< 95%		
	Over 1 month		< 90%		

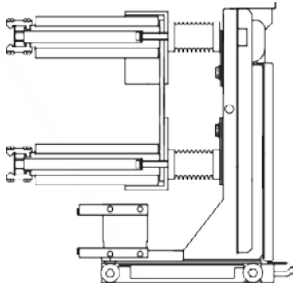

Isolation switching device

The device is used to disconnect the upstream and downstream circuits within the compartment, with the installation position being the same as the withdrawable circuit breaker, and equipped with a device to lock it in the service position.

Electrical features

Rated voltage	Ur	kV	12~17.5	
Phase clearance		mm	210	275
Rated normal current	Ir	A	1250	3150
Short-time withstand current (3 s)	I _{lk}	kA	31.5	31.5

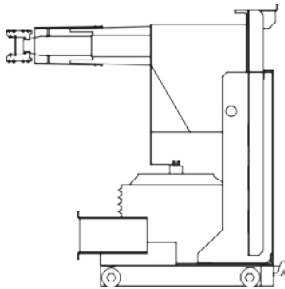

Voltage transformer switching device

This device is a mobile switching device integrated with a medium-voltage voltage transformer, used for voltage measurement of the main busbar within the compartment, with the same installation position as the withdrawable circuit breaker.

Electrical features

Rated voltage	Ur	kV	12~17.5	
Phase clearance		mm	210	275

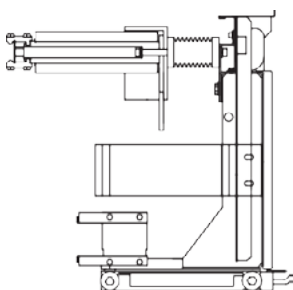

Earthing switching device

This device is a safety accessory used to replace the withdrawable circuit breaker for busbar earthing. It is locked in the service position via a position lock.

Electrical features

Rated voltage	Ur	kV	12~17.5	
Phase clearance		mm	210	275
Short-time withstand current (3 s)	Ir	A	31.5	31.5

Components



Withdrawable Component

Operation The “insertion” function is achieved through the following components:

- Chassis cart—used to support the circuit breaker (movable part)
- Fixed base with contact arms and contacts
- Low-voltage plug

Operation

The circuit breaker can be in 3 stable positions:

- Service position: The circuit breaker is inserted and locked, and the low-voltage plug is connected
- Test position: The circuit breaker is withdrawn and locked, and the low-voltage plug remains connected
- Disconnected position: The circuit breaker is withdrawn and locked, and the low-voltage plug is disconnected

Function

- Insertion/withdrawal of the circuit breaker is achieved. Insertion operation must be performed with the switchgear door closed.
- Interlocking of circuit breaker status and switching device: The switching device can only be inserted or withdrawn when the circuit breaker is in the Open state for operational safety.
- Interlocking of low-voltage plug and switching device: The switching device can only be inserted after the low-voltage plug is connected.
- Mechanical interlock between the switching device and the earthing switch: The TCB switching device and the earthing switch are set with a rigid mechanical interlock.
- Protective shield (IP2X): When the circuit breaker is withdrawn, the guard automatically isolates the fixed contacts to prevent personnel from touching them.
- Maintenance operations:
 - Lock the shutter mechanism in the locked position using a padlock.
 - Unlock the blocking shutter mechanism to contact the fixed contacts.
- (Optional) The operating holes of the switching device interlock with the compartment doors, ensuring that the circuit breaker can only be operated when the switchgear door is closed.

Accessories

- 1 set of lock system: Used to lock the operating rod slot to prevent insertion operation
- Circuit breaker compartment door lock

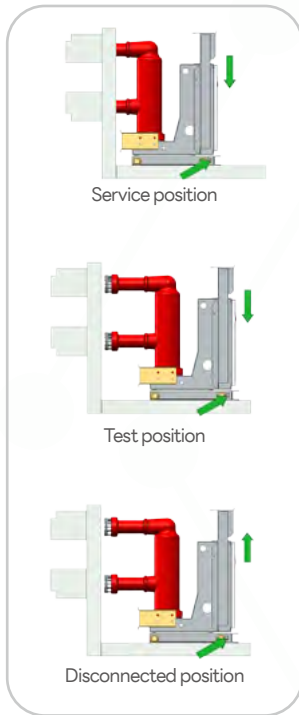

Maintenance trolley



Trolley handle



Energy storage handle



Earthing switch operating handle

Packaging

The switchgear is packaged according to the specific requirements of the customer.

During international transport, the switchgear must be:

- Placed on a wooden pallet and fixed with bolts
- Sealed with polyethylene film
- Sealed with aluminum foil welding
- Included humidity indicator
- Placed desiccant bags for transport in the panel
- Sealed with fumigated wooden box board
- Stored for a maximum period of: 6 months

Desiccants are provided inside the switchgear for more effective moisture prevention.

Busbars are not pre-installed, and their materials, fasteners, and accessories must be packaged separately.

The use of desiccant bags complies DIN 55473, as detailed below:

- Blue indicator: Container is dry
- Pink indicator: Container is damp (relative humidity exceeds 40%)

Transport

The appropriate transport method should be selected based on the final destination and customer requirements.

For international transport, switchgears are shipped with appropriate packaging based on current conditions (e.g., packaging suitable for sea transport).

A detailed packing list will be provided to the carrier during transport to ensure smooth customs clearance at the destination port.

Transportation must comply with the following guidelines:

- Ensure the switchgear should be always upright during the transport
- Provide four ring-type lifting lugs provided for lifting with straps or steel cables
- Ensure the switchgear should be transported inside a sealed container
- Do not stack switchgears on top of each other
- Always keep the container dry
- Only use lifting equipment that meets the rated values of the switchgear

* Consideration must be given to its high center of gravity characteristics. Loading and unloading operations can only be performed when all personnel and materials are properly protected and when using cranes, forklifts, or hydraulic carts for handling.

Crane loading/unloading requirements:

- Lifting ropes and shackles that conform to the load capacity must be provided (opening width ≥ 30 mm, fastening hole diameter 30 mm).
- Lifting ropes and crane hook connection lines must maintain an angle of at least 60° with the horizontal plane.
- Lifting ropes must be ensured in good condition
- Crane operators must have appropriate qualifications
- The crane must be located on stable ground and accurately positioned.



TOP



KEEP DRY



LIFTING
ARRANGEMENT

Marks Required
for Transport

Transport and Installation

Delivery

Upon arrival, the switchgear, circuit breakers, and components should be immediately checked for signs of transport damage.

- Any visible external damage must be confirmed by the driver on the freight documentation
- Efforts must be made to check for moisture and its harmful effects
- Based on insurance claim conditions, any damage must be reported in writing to the delivery transport agent within two weeks
- Hidden damage can only be detected after removing the packaging material. Claims for subsequent transport damage must be reported to the manufacturer within one week of delivery.

All components and accessories must be cross-checked against the packing list, with key items including:

- Components
- Tools
- Spare Parts

The manufacturer's serial number on the delivery note must match the serial number on the switchgear nameplate exactly.

The external unloading of the switchgear must follow the operating markings on the packaging crate.

Unpacking

Switchgear

The switchgear must always be kept upright. Switchgear unloading must be performed using a crane with sufficient lifting capacity, and care must be taken during lifting operations to avoid excessive swaying of the equipment. The following unpacking procedures are for reference only, and actual operations primarily depend on the available resources in the work area:

- Remove the top cover of the container
- Open the protective panels around the container
- Remove the fixing bolts between the switchgear and the transport container chassis

Notes: All removed bottom fixing bolts must be reused after the switchgear is positioned on the designated foundation.

- Equip the switchgear with four lifting lugs for use with lifting straps or steel cables.
- Lift the switchgear vertically off the pallet.
- Remove the pallet from the bottom of the switchgear and place it in a safe position.
- Use a crane to slowly move the switchgear to the installation position or a temporary storage location.

Notes: Avoid subjecting the panel to severe impacts or vibrations during handling. Do not walk on the top of the switchgear (which may cause damage to the pressure relief vent).

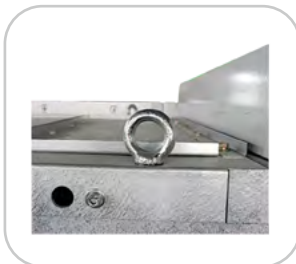

View of One of the Top Lifting Lugs of the Circuit Breaker



View of Switchgear Lifting



View of One of the Side Lifting Lugs of the Circuit Breaker

Unpacking

Circuit breaker

The circuit breaker is individually packaged in a fumigated wooden box and must remain in its packaging until delivery and inspection.

The unpacking process for the circuit breaker is the same as for the switchgear. Each side of the circuit breaker is equipped with 2 lifting lugs for hoisting the circuit breaker onto a maintenance vehicle.

Notes: When placed on the maintenance cart, the top panel must remain level; once positioned, confirm that the locking device is fixed before disconnecting the lifting hook.

Intermediate Storage

The switchgear is packaged for transport and storage when it leaves the factory. The switchgear can be stored for up to 6 months under the following conditions:

- The switchgear is placed outdoors on a dry and covered ground or moisture-proof insulating material.
- After inspection for transport damage, the original packaging must be restored to its delivery condition.
- The switchgear should be stored in a clean, dry, and well-ventilated environment.
- The storage area must prevent the following factors from causing equipment deterioration:
 - a. Water
 - b. Water vapor
 - c. Salt-containing air
 - d. Any type of contaminants
 - e. Microorganism

Transport and Installation



Precautions

- The switchgear must be kept upright during storage.
- Stacking switchgears is strictly prohibited.
- The switchgear is not weatherproof, and outdoor storage is prohibited (rainwater and moisture may cause irreversible damage).
- For short-term storage (≤ 2 weeks), the switchgear must be covered with a dustproof plastic sheet.
- Do not walk on top of the switchgear (which may cause damage to the pressure relief device).

Additional requirements for long-term storage:

- Use heat-sealing moisture-proof cloth to wrap the panel (with the maintenance door must be retained as a visual window);
- Regularly replace desiccant bags;
- Periodically inspect the integrity of the packaging seals.

Operational procedures after unpacking the equipment:

- Perform basic maintenance tasks;
- Test the minimum operating threshold of the electrical control coils ($\geq 85\%$ of rated voltage).

Installation qualification requirements:

To ensure the best installation process and quality standards, on-site installation of the switchgear must be performed by qualified personnel who have received professional training, or supervised throughout the operation by a responsible engineer.



Requirements for On-site Conditions

Before installing TAP17, the power distribution room must meet the following requirements:

- All civil works must be completed, including the lighting system and power supply access.
- The room must have a closing function and a dry environment, and be equipped with ventilation facilities.
- All cable laying and pre-installation work (wall penetrations, cable trenches, etc.) must be completed before power and control cables are introduced into the switchgear

Installation requirements for special structures:

When the switchgear has structures like a secondary busbar compartment installed at the top, any of the following conditions must be met:

- The ceiling height must be sufficient to accommodate the full stroke of the pressure relief baffle.
- A top pressure relief channel system must be installed.



Installation of Switchgear

Installation steps:

- Remove the lifting lugs
- Transport the switchgears to the pre-designated installation location in the sequence shown on the switchgear layout diagram
- Align the switchgear with the steel-reinforced concrete with foundation rails according to the assembly diagram.
- Connect each switchgear using fasteners
- Remove the fixing screws of the vertical intermediate partition in front of the busbar compartment
- Align each switchgear with the foundation frame one by one to ensure accurate positioning and vertical alignment (the vertical deviation of the switchgear edges must not exceed 2 mm, with particular attention to the front), and connect the switchgears with bolts. If more than ten switchgears are involved, it is recommended to start the installation from the center.
- After the switchgears are assembled, fix them to the concrete floor with bolts, or weld/bolt them to the foundation frame



Final Installation Operations

- Inspect the painted areas of the switchgear for damage and re-coat if necessary.
- Inspect the bolt connections and tighten them as required, with particular attention to the bolts installed on-site for the busbar and earthing systems
- Thoroughly clean the switchgear
- Remove all foreign objects from inside the switchgear.
- Correctly reposition any parts like cover plates that were removed during the installation and wiring process.
- Check the smoothness of the isolating contacts and interlocking mechanisms, and lubricate again if necessary.
- Place the withdrawable circuit breaker component and connect the control wiring.
- Ensure doors are properly closed and locked



**POWERING GLOBAL ENERGY TRANSITION,
FULFILLING TGOOD COMMITMENT**

TGOOD ELECTRIC(300001.SZ)

Address: No.336 Songling Road,Laoshan District,Qingdao,China
Website:www.qdtgood.com E-mail: info@qdtgood.com
Tel: +86 532 8908 8929 Fax: +86 532 8908 3066