



Smart Integrated

CMD190

Low-voltage Switchgear Assembly

Catalogue 2026



COMPANY PROFILE

- Founded in 2004, TGOOD (Stock Code: 300001) was the first company listed on the Growth Enterprise Board of the Shenzhen Stock Exchange in 2009.
- The mission of TGOOD is to create the world's top brand of prefabricated power equipment
- TGOOD's intelligent modular prefabricated substations has occupied a 60% share of power grid and new energy markets.
- TGOOD has delivered product solutions to 6300+ customers, and provided 11,000+ prefabricated substations.
- TGOOD's prefabricated and integrated solutions have been implemented in 50+ countries and regions worldwide.

No.1

The world's No.1 brand of prefabricated substation equipment

The largest in World

One of the largest supplier for prefabricated substation

The largest in China

TGOOD is the largest R&D and production base for prefabricated substations in China

Only in China

The only manufacturer in China achieving digital, technological, specialized, and large-scale production of prefabricated substation.

Champion

MIIT manufacturing industry single item champion enterprise

Four Main Manufacture Factories



Sichuan Chengdu Manufacturing Factory



Hubei Yichang Manufacturing Factory

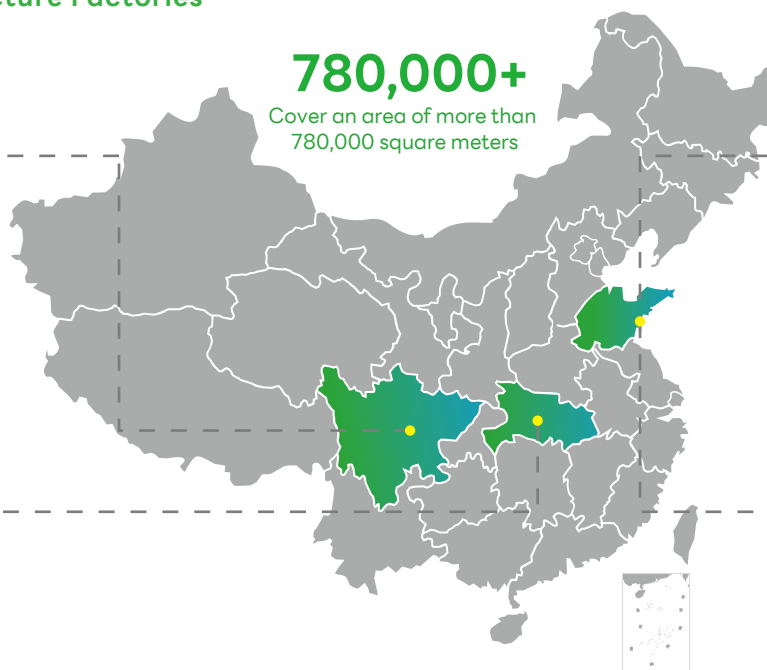

Qingdao West Coast Manufacturing Factory



Qingdao Free Trade Zone (China)

CMD190

Low-voltage Switchgear Assembly

| Application Scenarios



Large Public Buildings



Data Centers



Nuclear Power Plants

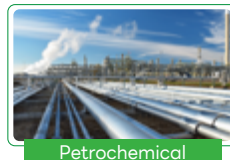

Petrochemical



Rail Transport



Electronic Factories

Table of Contents

Company Profile	2
Products	4
Product Overview	4
Technical Data	6
Electrical Data	6
Mechanical Data	6
Main Type	7
Incoming Cabinet	7
Capacitance Compensation Cabinet	8
Fixed Partition Cabinet	9
Drawer Cabinet	10
Qualifications and Honors	11
Intelligent Distribution	12
Recommended Scheme for Primary System	14
Transport and Installation	18



CMD190 Low-voltage Switchgear Assembly



General Description

CMD190 low-voltage switchgear assembly is a compact, intelligent, and highly reliable switchgear developed by TGOOD in accordance with standards such as IEC61439, IEEE323, IEEE384, RCC-E, and GB7251. It is mainly used in power plants, substations, industrial enterprises, and civil buildings to receive and distribute electrical energy, and to implement functions such as control, protection, monitoring, and communication.

■ Core Scenarios in Power Systems

- Rail Transport and Aerospace
- Ships and Oil Rigs
- Public Utilities
- New Energy Materials
- Petrochemical Engineering
- New Energy Power Generation, etc.
- Communications, Data Centers, and Smart Computing Centers
- Municipal Water Supply and Sewage Treatment Plants
- Commercial Centers, Hotels, and Residences
- Nuclear Power Plants, and Military Industries
- Industrial and Mining Enterprises

■ Technical Features

- CMD190 low-voltage switchgear assembly has more advantages over traditional switchgears
- Highly intelligent
- Back-to-back arrangement of panels and economical layout of power distribution circuits
- Full-series standardization and use of standard components
- Appropriate protection degree designed according to different working and environmental conditions
- Flexible combination of fixed and withdrawable models in one panel
- Anti-arc design and panel protection against earthquake, vibration and impact
- Convenient upgrading and modification, and maintenance-free operation to the maximum degree
- High operation continuity and reliability.
- Compact structure and reduced panel volume
- Sufficient protection for operators' personal safety



Personal Safety

- Self-tapping screws feature robust structure, high structural strength, excellent surface treatment, and reliable earthing continuity, with protection degree up to IP44.
- The distribution busbar system has functions of insulation, isolation, flame resistance and self-extinguishing, and does not contain CFCs and halogens.
- The primary and secondary cable connection compartments are distinctly separated, with the primary and secondary cables kept apart, and the components and wiring within the functional units are arranged in a more organized and visually appealing manner.



Convenient Operation

- The service life of primary connectors in next-generation drawers is increased by over 5 times, with low operating temperature rise, along with reliable and easy operation.
- The secondary connectors in drawers adopt the automatic guiding and insertion technology, and offer flexible and reliable connection.
- The interlocking mechanism simultaneously achieves switch operation and mechanical interlocking of drawers, and features convenient and reliable operation.
- The roller design on the drawer unit allows for easy and smooth operation, and achieves good interchangeability.

Design for Special Operating Environment

- Tropics
- Earthquake-affected areas
- Air-raid shelters
- Ships
- Offshore regions

Maintenance and Service

- When not in use, the equipment should be stored in a dry, clean, and well-ventilated indoor environment, with temperatures ranging from -25°C to $+55^{\circ}\text{C}$
- Real-time support is provided for daily operations: including maintenance contracts, technical assistance, spare parts supply, corrective and preventive maintenance, and training on operation and maintenance.
- Service is provided in relation to equipment installation.

Technical Data

Electrical Data	Unit	Parameter Value
Rated operating voltage	V	380~690
Rated insulation voltage	V	800, 1000
Rated impulse withstand voltage	kV	8, 12
Rated frequency	Hz	50, 60
Rated current of horizontal busbar	A	200~7500
Rated short-time withstand current of horizontal busbar	kA/1s	30~120
Rated peak withstand current of horizontal busbar	kA	63~264
Rated current of vertical busbar	A	200~4300
Rated short-time withstand current of vertical busbar	kA/1s	20~85
Rated peak withstand current of vertical busbar	kA	40~187
Arc fault resistance		100kA/0.5s

Mechanical Data	Unit	Parameter Value
Protection degree of enclosure	/	IP30~IP44
Impact resistance	/	IK05~IK10
Internal segregation type	/	2b~4b
Seismic resistance	Intensity	9 degree
Altitude for use	m	5000
Nominal dimension	Height (H)	mm 2200, 2300
	Width (W)	mm 400, 600, 800, 1000, 1200, 1400, 1600
	Depth (D)	mm 600, 800, 1000, 1200



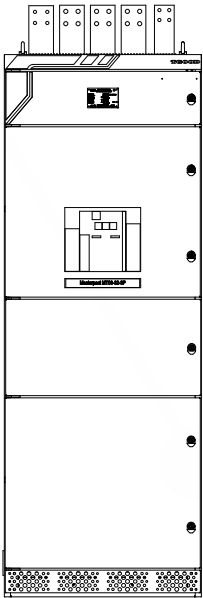

Main Features

- System power incoming line
- Multiple incoming and outgoing ways
- Real-time monitoring, and over-voltage and over-current protection
- Three major functional compartments including functional unit compartment, busbar compartment, and cable connection compartment
- Strict separation of functional units to effectively prevent the expansion of accidents

1



- Concealed installation design: concealed installation holes to facilitate foot bolt installation

2



- Scientific and aesthetic layout, and safe and convenient operation and maintenance
- Maximum current up to 7,500 A

3



- Anti-magnetic structural design: non-magnetic materials of busbar clamp installation beam to effectively prevent eddy current heating
- Removable busbar compartment: removable upper part of the horizontal busbar compartment to facilitate on-site busbar assembly

Capacitance Compensation Cabinet

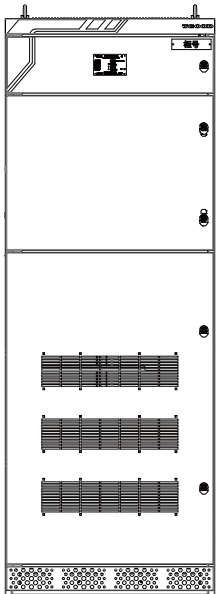

Main Features

- Reactive power compensation
- Modular design
- Hybrid compensation, fault self-diagnosis, over-voltage, under-voltage, over-current, short circuit, overtemperature, and harmonic protection
- Protection with surge arrester, and unbalanced protection against internal faults of capacitors

1



- Capacity: 60 – 380 kVar
- organized component arrangement, easy operation and maintenance, excellent heat dissipation, and effective protection for safe operation

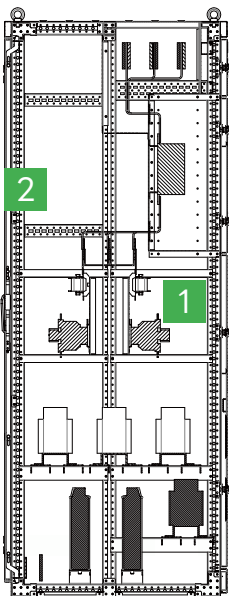

2



Sound ventilation and heat dissipation channels: air inlet or honeycomb holes at the lower front of the switchgear, internal ventilation channels, and fan at the upper back of the switchgear ensure effective ventilation and heat dissipation.

Fixed Partition Cabinet

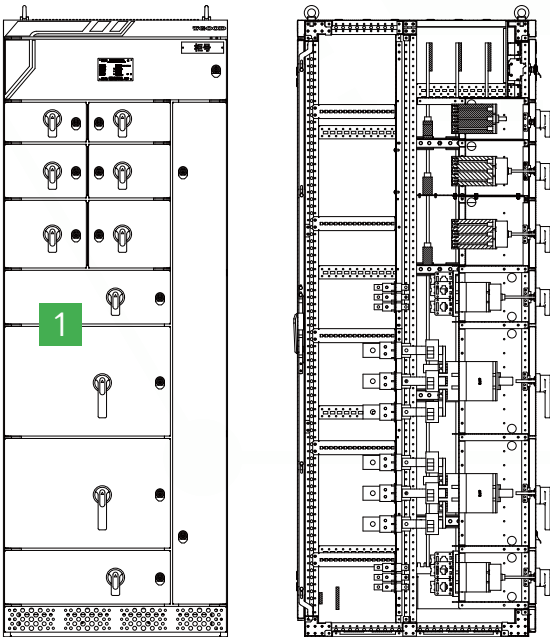

Main Features

- Power supply cabinet
- Functional units at a fixed interval
- Strict separation of functional units to effectively prevent the expansion of accidents
- Clear circuit labeling, and easy and quick maintenance and inspection
- Large and reasonable cable connection space
- Reasonable layout: primary and secondary incoming lines are separated for easy connection, inspection and maintenance by users

1



- Tidy and aesthetic panel
- Plug-in switches
- Current ratings: 32 to 800 A
- Specifications: 150/2, 150, 200, 300, 350, 400, and 450

Drawer Cabinet

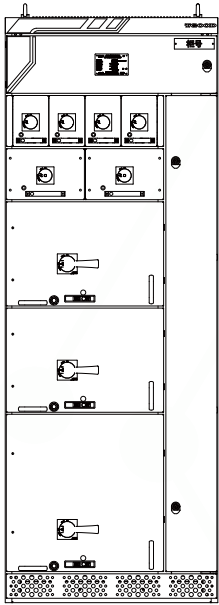

Main Features

- Power supply cabinet
- Functional units of a drawer type
- Specifications: 8E/4, 8E/2, 6E, 8E, 12E, 16E, and 24E
- Current ratings: 32 to 630 A
- Simple and elegant panel design
- High component installation density
- Easy and quick maintenance and inspection
- Large and reasonable cable connection space

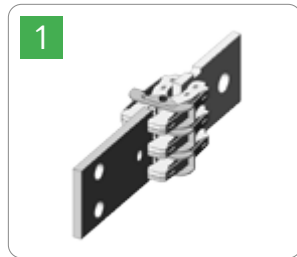
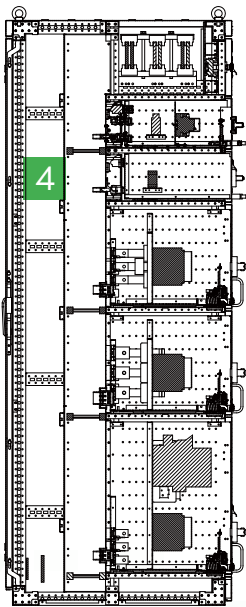
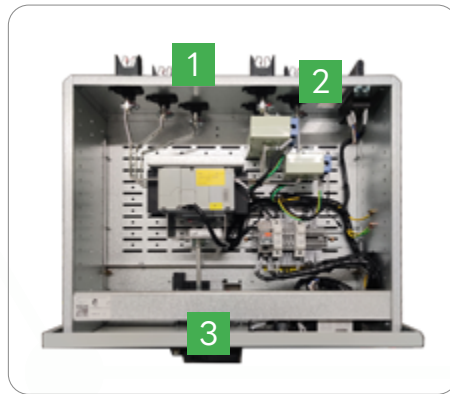

- Double-clamp structure of drawer connectors, good contact performance, and low temperature rise
- Plug-in secondary connectors, easy installation and maintenance, and sufficient clamping force
- Swing-in drawers, easy operation, and no damage to connectors and components

Qualifications and Honors



This entire product series has passed all type tests and certifications according to international or national standards, including incoming cabinets, interconnection cabinets, reactive power compensation cabinets, fixed partition cabinets, drawer cabinets, dual-power transfer cabinets, motor frequency conversion soft-start cabinets, filter cabinets, etc.

In addition to type tests, this series has also passed special environmental tests such as EMC, seismic, aging, high altitude, internal fault arc, weather resistance, and salt spray resistance tests.

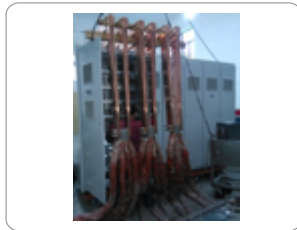

Nuclear-grade design and manufacturing capability: this series has passed aging, seismic tests, and expert evaluation, and obtained the national nuclear-level safety equipment design and manufacturing license.



This series has adopted over 30 independent core patent technologies, awarded the second prize for scientific and technological progress in Chengdu, and honored as provincial and ministerial-level nameplate products.

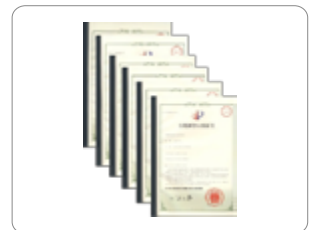

Intelligent Distribution

Intelligent Distribution

Small footprint

The cabinet can accommodate 24 circuits
+ Saves 33% of installation space

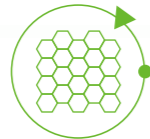

Edge computing gateway

+ The back-end monitoring system is simple
+ Real-time monitoring via mobile app



Status monitoring

Cabinet status visualization
+ Switch data visualization
+ Meter data visualization
+ Data cloud upload option



Circuit breaker characteristic monitoring

Circuit breaker energy storage coil status monitoring
+ Circuit breaker real-time data monitoring
+ Circuit breaker health monitoring
+ Circuit breaker six-point temperature measurement

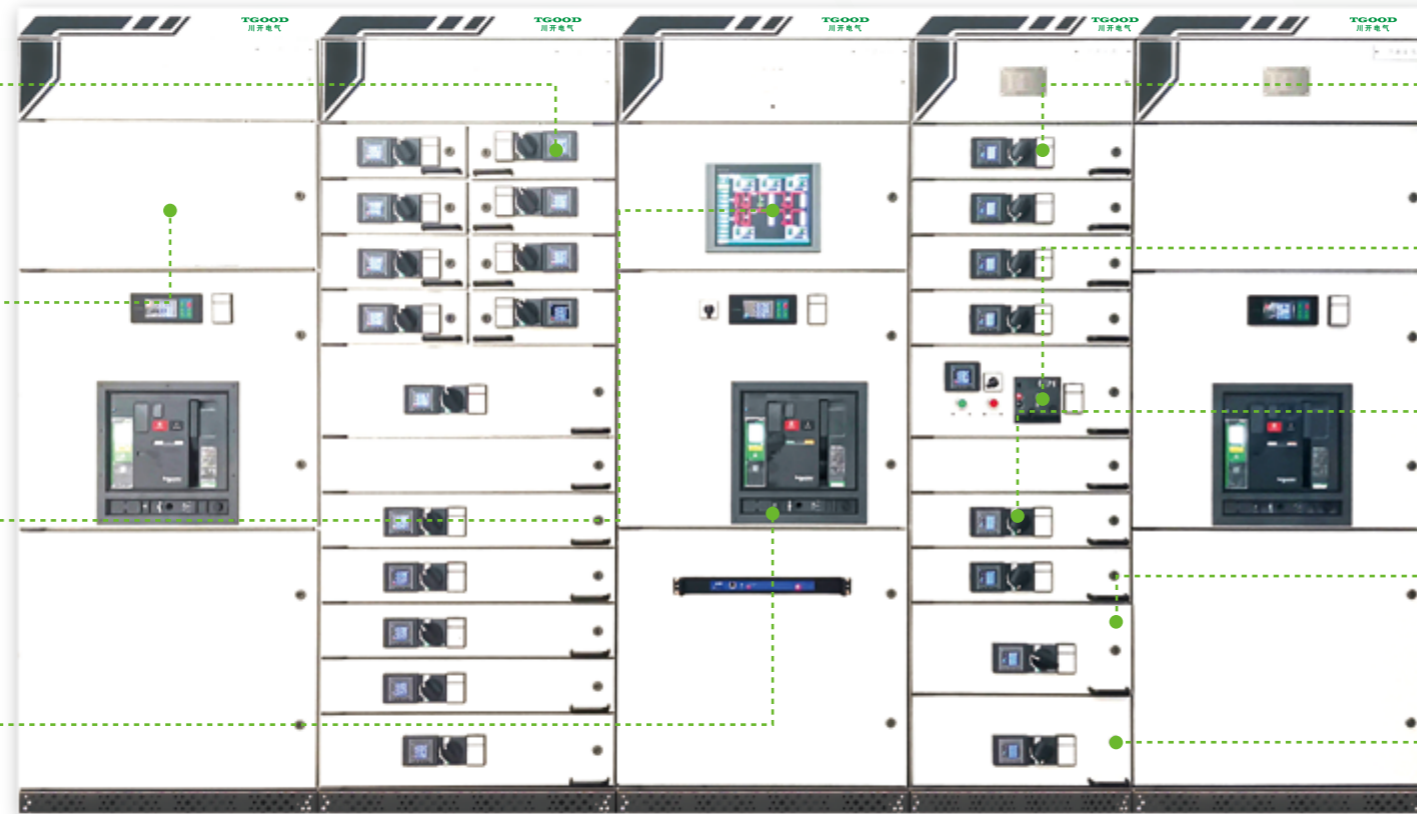

Circuit monitoring

Circuit real-time data monitoring
Power quality real-time monitoring (63rd harmonic)
Three-phase wireless temperature measurement, temperature rise alarm
Switch operation and fault count recording
Leakage current monitoring



Electric control

Remote control electric operation

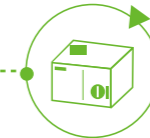

Current transform

Transformer integration, easy maintenance, and no power outage during replacement

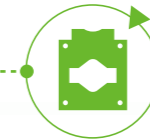

Secondary connection

Modular integration of secondary equipment, 70% reduction of connection points
All low voltage electric settings on the door



Primary connection

Fixed connection between the circuit breaker and copper busbar, safer and more reliable

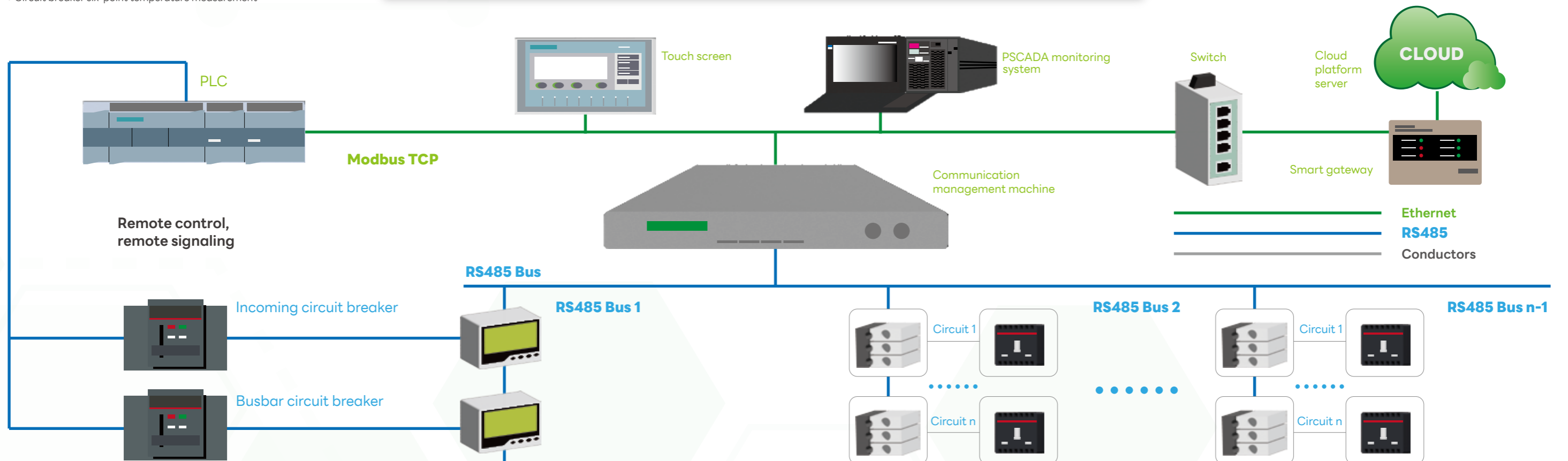
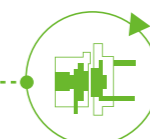

Recommended Scheme for Primary System

Scheme No.	01				02			
Main Circuit Diagram								
Purpose	Incoming, interconnection, feeder				Interconnection			
Switch manufacturer	Schneider, ABB, Changshu Switch, LAZZEN, People Electric, etc.				Schneider, ABB, Changshu Switch, LAZZEN, People Electric, etc.			
Frame current (A)	Below 1600	2000~3200	4000	5000~6300	Below 1600	2000~3200	4000	5000~6300
Width (mm)	600	800	1000	1200	600	800	1000	1400
Depth (mm)	800/1000	800/1000	1000/1200	1000/1200	800/1000	800/1000	1000/1200	1000/1200
Height (mm)	2200				2200			

Scheme No.	03				04			
Main Circuit Diagram								
Purpose	Dual power transfer				Reactive power compensation			
Switch manufacturer	Schneider, ABB, Changshu Switch, LAZZEN, People Electric, etc.				Schneider, ABB, Changshu Switch, LAZZEN, People Electric, etc.			
Switch current(A)/ Compensation circuit	Below 1600	800~1200	1600~3000	4000	6-way (180kVar)	8-way (240kVar)	10-way (300kVar)	12-way (360kVar)
Width (mm)	800	800	1200	1400	600	800	1000	1200
Depth (mm)	800/1000	800/1000	1000/1200	1000/1200	800/1000	800/1000	1000/1200	1000/1200
Height (mm)	2200				2200			

Recommended Scheme for Primary System

Scheme No.	05	06
Main Circuit Diagram		
Purpose	Dual-frame switch power supply cabinet	Triple-frame switch power supply cabinet
Switch manufacturer	Schneider, ABB, Changshu Switch, LAZZEN, People Electric, etc.	Schneider, ABB, Changshu Switch, LAZZEN, People Electric, etc.
Frame current (A)	Below 3200	Below 1600
Width (mm)	800	800
Depth (mm)	1000/1200	1000/1200
Height (mm)	2200	2200

Scheme No.	07	08		
Main Circuit Diagram				
Purpose	Fixed partition feeder cabinet	Drawer feeder cabinet		
Switch manufacturer	Schneider, ABB, Changshu Switch, LAZZEN, People Electric, etc.	Schneider, ABB, Changshu Switch, LAZZEN, People Electric, etc.		
Frame current (A)	Below 3200	Below 3200	Below 1600	Below 1600
Width (mm)	800	800	800	800
Depth (mm)	1000/1200	1000/1200	1000/1200	1000/1200
Height (mm)	2200		2200	

Recommended Scheme for Primary System

Scheme No.	09	10
Main Circuit Diagram		
Purpose	Frame switch, partitioned mixed cabinet	Frame switch, drawer mixed cabinet
Switch manufacturer	Schneider, ABB, Changshu Switch, LAZZEN, People Electric, etc.	Schneider, ABB, Changshu Switch, LAZZEN, People Electric, etc.
Frame current (A)	Below 3200	Below 3200
Width (mm)	800	800
Depth (mm)	1000/1200	1000/1200
Height (mm)	2200	2200

Scheme No.	11		
Main Circuit Diagram			
Purpose	Frame switch, partitioned mixed cabinet		
Switch manufacturer	Schneider, ABB, Changshu Switch, LAZZEN, People Electric, etc.		
Frame current (A)	Below 75	90~132	160~355
Width (mm)	600	800	1000
Depth (mm)	800/1000	1000/1200	1000/1200
Height (mm)	2200		

Recommended Scheme for Primary System

Scheme No.	13				14			
Main Circuit Diagram								
Purpose	Fixed partition PC unit circuit				Drawer PC unit circuit			
Frame current (A)	Below 160	160~250	315~400	630	Below 100	160~250	315~400	630
Unit height (mm)	150 200 250/2	200/250	300/350/400	300/350/400	200	200/250	300/350/400	

Scheme No.	15				16			
Main Circuit Diagram								
Purpose	Fixed partition PC unit circuit				Drawer PC unit circuit			
Frame current (A)	Below 100	160~250	315~400	630	Below 100	160~250	315~400	630
Unit height (mm)	200	250	300/350/400	300/350/400	200	250	300/350/400	

Transport

This entire product series has passed all type tests and certifications according to international or national standards, including incoming cabinets, interconnection cabinets, reactive power compensation cabinets, fixed partition cabinets, drawer cabinets, dual-power transfer cabinets, motor frequency conversion soft-start cabinets, filter cabinets, etc.

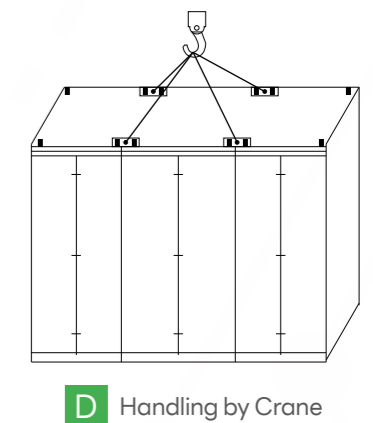
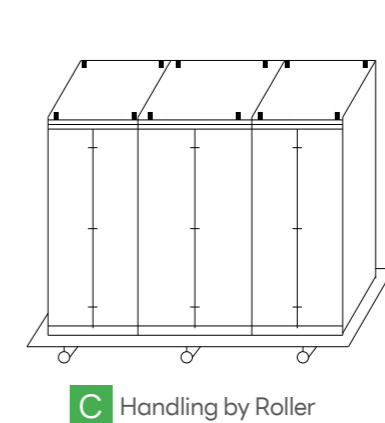
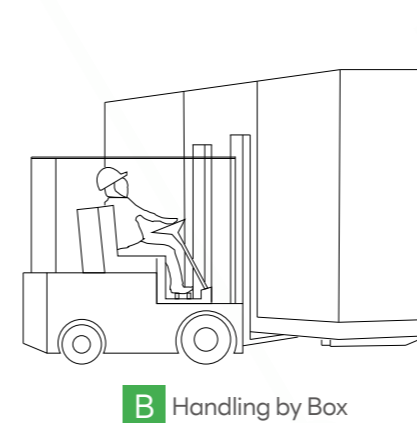
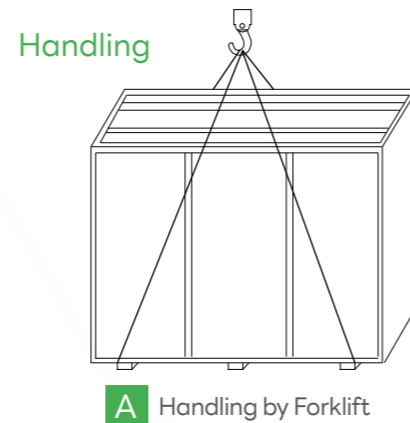

Installation

Dimension Requirements for Project Installation:

- When the product is arranged in a single row, the minimum width of the front operation corridor is 1,500 mm, the minimum width of the rear maintenance passage is 800 mm (1,000 mm for fixed cabinets), and the minimum width of the side maintenance passage is 800 mm.
- When the product is arranged in double rows, the minimum width of the front operation corridor is 1,800 mm, the minimum width of the rear maintenance passage is 800 mm (1,000 mm for fixed cabinets), and the minimum width of the side maintenance passage is 800 mm.

Basic Diagram for Installation with Bottom Entry and Bottom Exit

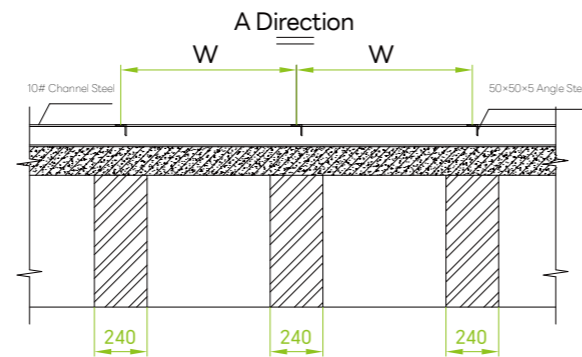
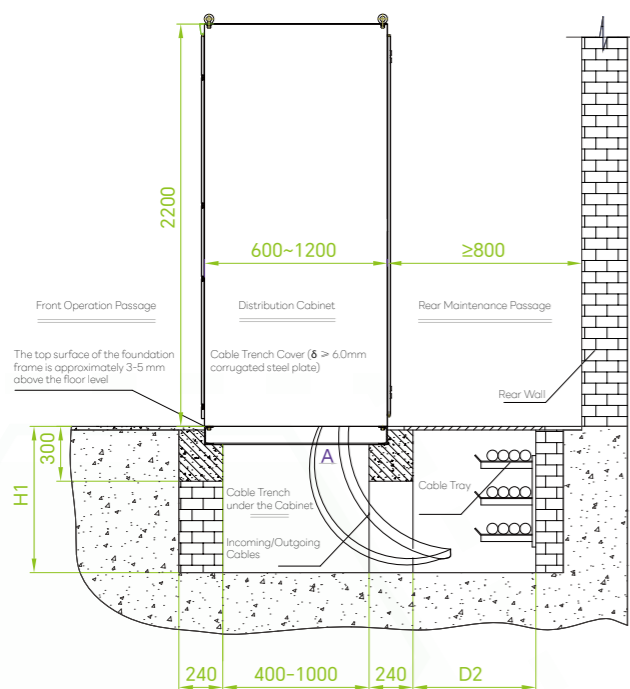

Notes:

- The steel channels for installation are made of 10# channel steel, and the stiffeners are 50×50×5 angle steel.
- For the bolted connection of the panel, $\phi 14$ holes are drilled on steel channels and M12 nuts are welded inside steel channels, while no drilling is required for the welded connection of the panel.

Foundation Diagram for Installation with Top Entry and Top Exit

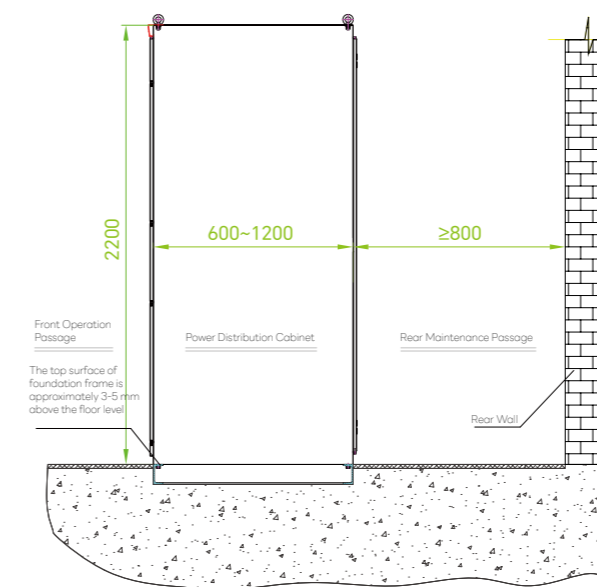

Installation of Steel Channel on Foundation

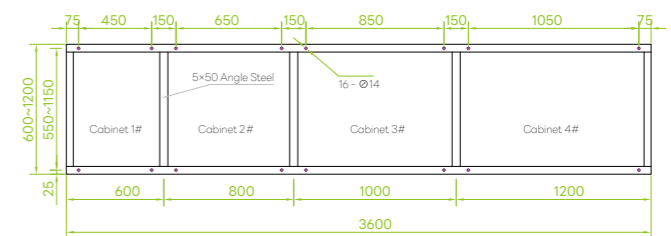

Notes:

- The height of the cable trench (H) and the width of the main cable trench (D) should be designed by the user based on the number of cables.
- The dimensions (W) in the "A"-direction view should be determined based on the width of the switchgear.
- The cable trench cover plate should be level with the floor.
- Along both sides of the cable trench, 40×6 flat steels were embedded and connected to the earthing network to fix the cable tray and also serve as an earthing body.
- The drainage slope of the cable trench bottom should be no less than 0.5%, and it should slope towards the outside of the building.



**POWERING GLOBAL ENERGY TRANSITION,
FULFILLING TGOOD COMMITMENT**

TGOOD ELECTRIC(300001.SZ)

Address: No.336 Songling Road,Laoshan District,Qingdao,China
Website:www.qdtgood.com E-mail: info@qdtgood.com
Tel: +86 532 8908 8929 Fax: +86 532 8908 3066