



**Smart Integrated**

**66kV**

**Renewable Energy Step-Up Kiosk**

**Catalogue 2026**



## COMPANY PROFILE

- Founded in 2004, TGOOD (Stock Code: 300001) was the first company listed on the Growth Enterprise Board of the Shenzhen Stock Exchange in 2009.
- The mission of TGOOD is to create the world's top brand of prefabricated power equipment
- TGOOD's intelligent modular prefabricated substations has occupied a 60% share of power grid and new energy markets.
- TGOOD has delivered product solutions to 6300+ customers, and provided 11,000+ prefabricated substations.
- TGOOD's prefabricated and integrated solutions have been implemented in 50+ countries and regions worldwide.

**No.1**

The world's No.1 brand of prefabricated substation equipment

**The largest in World**

One of the largest supplier for prefabricated substation

**The largest in China**

TGOOD is the largest R&D and production base for prefabricated substations in China

**Only in China**

The only manufacturer in China achieving digital, technological, specialized, and large-scale production of prefabricated substation.

**Champion**

MIIT manufacturing industry single item champion enterprise

## Four Main Manufacture Factories



Sichuan Chengdu Manufacturing Factory



Hubei Yichang Manufacturing Factory

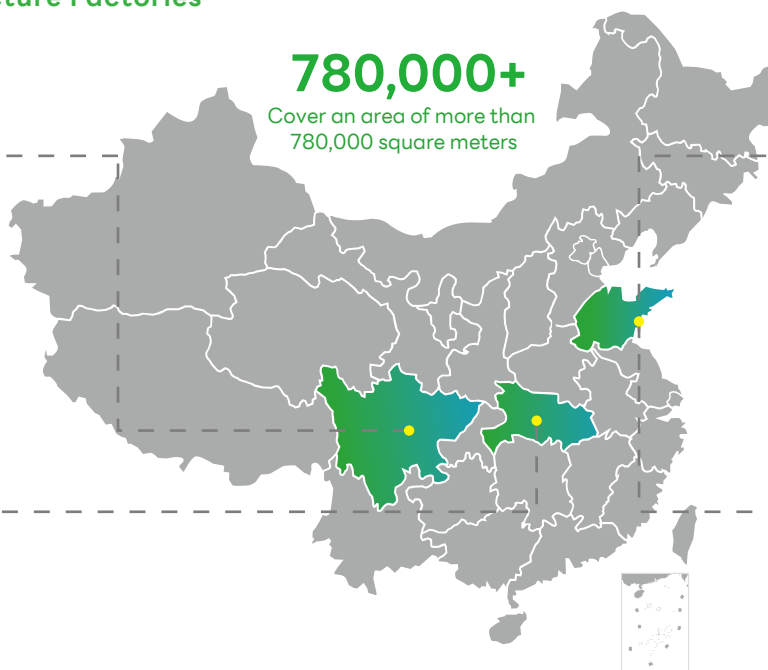

Qingdao West Coast Manufacturing Factory



Qingdao Free Trade Zone (China)

# 66kV New Energy Step-Up Kiosk

## | Application Scenarios



## Table of Contents

Company Profile	2
Products	4
Product Overview	4
Technical Data	7
Electrical Data	7
Design and Structure	12
New Energy Step-Up Kiosk	12
72.5 kV Blue GIS	14
69 kV Transformer and Cooler	15
Low-voltage Switchgear	17
Suggested Foundation Plan	17
Transport and Lifting	18
Transport Requirements	18
Disassembly Requirements	18
Lifting Diagram	18
Lifting Requirements	19
Storage Requirements	19



# 66 kV New Energy Step-Up Kiosk



## Product Overview

The 66 kV New Energy Step-Up Kiosk is core equipment that integrates key primary and secondary equipment such as 72.5 kV GIS, transformer, low-voltage switchgear, measurement and control devices through a prefabricated substation for integrated assembly and factory prefabrication. It is widely used in new energy power generation, distribution loads, and other major application scenarios including offshore photovoltaic generation, offshore wind power, large-scale onshore wind power, and onshore photovoltaic generation.

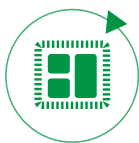

Clean air insulated



Strong short-circuit resistance



Intelligent HVAC

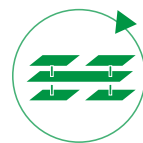

High corrosion resistance



## Applicable Standard

- ▶ IEC 62271-202:2014, High-voltage switchgear and controlgear—Part 202: High-voltage/low-voltage prefabricated substation, MOD
- ▶ IEC 62271-203:2011, High-voltage switchgear and controlgear—Part 203: Gas-insulated metal-enclosed switchgear for rated voltages above 52 kV, MOD
- ▶ GB/T 17467 High-Voltage/Low-Voltage Prefabricated Substations
- ▶ GB/T 7674 Gas-Insulated Metal-Enclosed Switchgear for Rated Voltages of 72.5 kV and Above
- ▶ GB/T 1094.1 Power Transformers - Part 1: General

The 66 kV New Energy Step-Up Kiosk is core equipment that integrates key primary and secondary equipment such as 72.5 kV GIS, transformer, low-voltage switchgear, measurement and control devices through a prefabricated substation for integrated assembly and factory prefabrication. It is widely used in new energy power generation, distribution loads, and other major application scenarios including offshore photovoltaic generation, offshore wind power, onshore large-scale wind power, and onshore photovoltaic generation.

- Rated voltage is up to 72.5 kV
- Transformer capacity is 2,500 kVA-12,500 kVA

## Typical Applications

The 66 kV New Energy Step-Up Kiosk can be used in various new energy or power distribution systems, such as:

### ■ New energy, for example:

- Onshore photovoltaic generation, and offshore photovoltaic step-up substations
- Onshore wind power, and offshore wind power step-up substations
- 72.5 kV energy storage systems

### ■ Core scenarios in power systems, for example:

- Substations and power plants
- Power system and utility distribution stations
- Switching stations, mobile power supply stations and substations

### ■ Rail transport, for example:

- Power supply systems for subways
- Power supply for high-speed rails and airports

## Technology

- A grid-shaped layout and factory prefabrication are adopted to achieve high integration, compact structure and small footprint.
- 72.5 kV Blue GIS, with clean air as an insulating gas and the vacuum breaking technology, is fully insulated and enclosed, and maintenance-free.
- Transformers feature strong short-circuit resistance, efficient overload capacity, and excellent seismic performance, capable of supporting forced oil-air cooling, water cooling, and radiator self-cooling schemes.
- The prefabricated substation with high corrosion resistance adopts a fully enclosed design, and features a high protection degree.
- Intelligent HVAC can achieve precise cooling and high energy efficiency.
- The prefabricated substation adopts a container design, which can meet the requirements of container ship transport, and can realize multi-layer stacking of containers for convenient transport.
- Type-F bushing plug-in structures are adopted to achieve plug-and-play operation, and accessories such as surge arrester adopt a cable rear plug-in design for flexible expansion.



## Personal Safety

- A sound earthing system is in place to ensure the product is properly earthed and the enclosure is safe to touch.
- With an anti-arcing classification of IAC 31.5kA/0.5s, the product is designed with a dedicated arcing pressure relief channel that ensures the safety of operators.
- Breathable air is used to insulate the gas compartment, eliminating the hazards to maintenance personnel caused by SF<sub>6</sub> gas leakage in traditional GIS.
- Reliable mechanical and electrical interlocks ensure that the operators are always in a safe state.
- High-voltage switchgear and transformer, adopting touchable Type-F bushing plug-in structure, are fully insulated and enclosed for effective protection of personnel safety.
- Intelligent HVAC enables precise cooling and accurate monitoring and control of temperature, humidity and other environmental parameters, to ensure that the operating environment meets requirements and protects personnel health.



## Operation Safety

- With a grid-shaped layout, compartments of low-voltage switchgear and transformer are completely partitioned by different compartments, which comply with LSC2B [Loss of Service Continuity Category/Type] as defined in IEC 62271-200.
- Protection, monitoring, and control systems are optional.
- Logical mechanical interlock prevents mis-operation.
- Maintenance and Service
  - When not in use, the product should be stored in a dry environment, shielded from light and rain, with a temperature range of -25 °C to +55 °C.
  - Real-time support is provided for daily operations: maintenance contracts, technical assistance, spare parts supply, corrective and preventive maintenance, and operation and maintenance training.
  - Installation-related service:
    - Installation environment analysis;
    - Diagnostic, adaptation and modification of kiosks.



## Reliability Quality and Service Life

- Strict type test and routine test
- Standardized and rigorous CNC production processes
- Quality and environmental management systems meet the requirements of ISO 9001 and ISO 18001.
- The expected service life is at least 25 years under normal operating conditions.

# Electrical Data - Kiosk

Name	Unit	Parameter Value
<b>Product Model</b>		ZBWH-72.5
Transformer's rated capacity	kVA	2500-12500
Rated frequency	Hz	50, 60
Rated high voltage	kV	72.5
Rated low voltage	kV	0.8, 1.14, 1.8
Transformer liquid surface temperature rise limit value (K)	K	≤ 53
Transformer winding temperature rise limit (K)	K	≤ 58
Rated short-time withstand current (HV side)	kA/s	31.5kA/4s
Rated peak withstand current (HV side)	kA	80
Rated short-time withstand current (LV side)	kA/s	85kA/1s
Rated peak withstand current (LV side)	kA	200
Rated short-time withstand current of earthing circuit	kA/s	31.5kA/2s
Rated peak withstand current of earthing circuit	kA	80
Internal arc fault current (HV side)	kA/s	31.5kA/0.5s
Power frequency voltage withstand test (HV side)	kV	160 (Phase-to-phase, phase-to-earth)
Power frequency voltage withstand test (LV side) ≤1.14 kV	kV	5 (Phase-to-phase and phase-to-earth)
Rated lightning impulse withstand voltage (HV connection line)	kV	380 (Phase-to-phase, phase-to-earth)
Rated lightning impulse withstand voltage (LV side) ≤1.14 kV	kV	12 (Phase-to-phase, phase-to-earth)
Enclosure protection degree (IP code)	kV	IP66 at maximum (Option: IP54 onshore)
Enclosure protection degree (IK code)	kV	IK10

- (1) Forced oil-air cooling, water cooling, heat sink or other cooling solutions may be selected based on actual needs  
 (2) The transformer may be placed either inside or outside the kiosk depending on onshore or offshore operation scenarios



# Electrical Data – 72.5 kV Blue GIS

Main Technical Data	Unit	Parameter Value
Rated voltage	kV	72.5
Rated current	A	1250
Rated short-circuit breaking current	kA	31.5
Rated frequency	Hz	50, 60
Rated short-time withstand current	kA	31.5
Rated short-time withstand current peak	kA	80
Rated short-circuit duration	s	4
Rated frequency 1min withstand voltage (disconnection)	kV	160+42
Rated lightning impulse withstand voltage peak value (disconnection)	kV	380+60
Gas leakage rate		≤0.1%
insulating medium in gas compartment		Dry air
Rated inflation pressure	MPa	0.5
Degree of protection	Panel	IP5X
	Gas Compartment	IP68
Internal arc and protection degree	/	31.5kA/0.5sAFLR



# Electrical Data - Transformer

Main Technical Data	Unit	Parameter Value
Transformer's rated capacity	kVA	2500-17600
Rated frequency	Hz	50, 60
Rated high voltage	kV	69 Voltage values can be designed according to applicable agreements.
Rated low voltage	kV	0.8, 1.14, 1.8
Transformer liquid temperature rise limit (K)	K	≤53
Transformer winding temperature rise limit (K)	K	≤63
Insulation level		HV: Um/LI/LIC/AC 72.5/325/360/140kV LV: AC 5kV (0.8kV) LV: AC 6kV (1.14kV) LV: AC 10kV (1.8kV)
Transformer tap range		±2×2.5% , ±5%
Connection group number		Yd11-d11(Dy11-y11)、Yd11(Dy11)、Dyn11
Insulation class		Class A



# Electrical Data - Low-voltage Switchgear

Main Technical Data	Unit	Parameter Value
Rated voltage	kV	0.8, 1.14, 1.8
Rated frequency	Hz	50, 60
Rated peak withstand current	kA	200
Rated short-time withstand current	kA/s	85kA/1s
Power frequency voltage withstand test ( $\leq 1.14$ kV)	kV	5 (Phase-to-phase and phase-to-earth)
Lightning impulse withstand voltage:	kV	12 (Phase-to-phase and phase-to-earth)

## Low-voltage universal circuit breaker

Fixed, manually/electrically operated, with the following parameters when the rated voltage is AC800V: rated insulation voltage  $U_i=1800V$ , impulse withstand voltage  $U_{imp}=18$  kV, rated operating voltage  $U_e=800V$ , rated current  $I_n=5000A$ , rated ultimate short-circuit breaking capacity  $I_{cu}=70kA$  (at AC800V), rated short-time withstand current  $I_{cw}=75kA/1s$ . The above parameters are determined according to different project voltages and circuit breaker manufacturers.

## Molded case circuit breaker

Fixed, manually operated, rated insulation voltage  $U_i=1250V$ , impulse withstand voltage  $U_{imp}=12$  kV, rated operating voltage  $U_e=800V$ , rated current  $I_n=320A$ , rated ultimate short-circuit breaking capacity  $I_{cu}=50kA$  (at AC800V), thermo-magnetic detachment (TMD); the above parameters are determined according to the different project voltages and molded case circuit breaker manufacturers.

## Incoming cable

Designed according to specific project requirements.

## Degree of protection

IP55 outdoors, or IP30 indoors, to be designed according to specific project requirements



# Typical Primary Scheme

## Typical Primary Scheme of New Energy Step-Up Kiosk

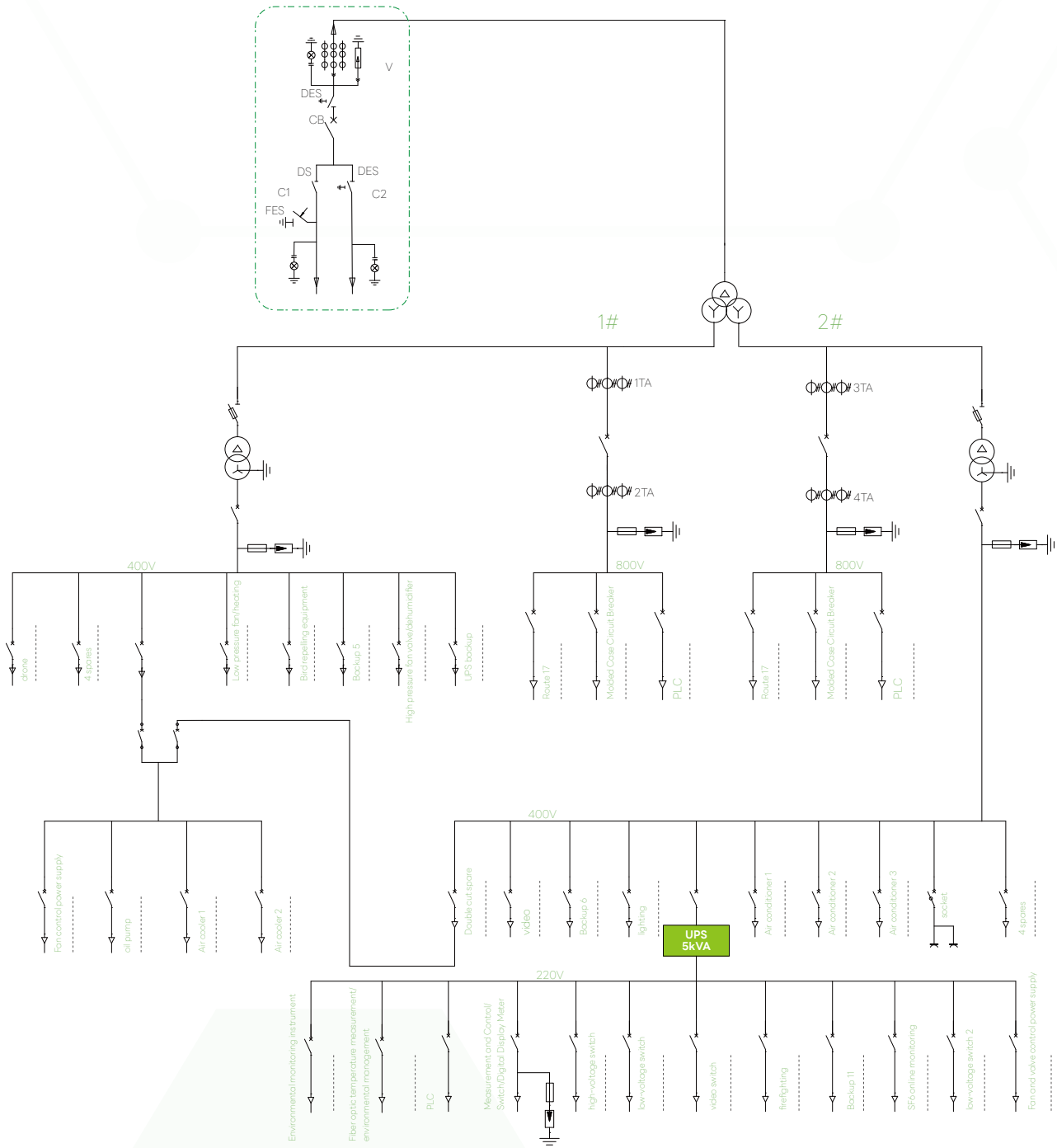

Apperance



Left side



Right side

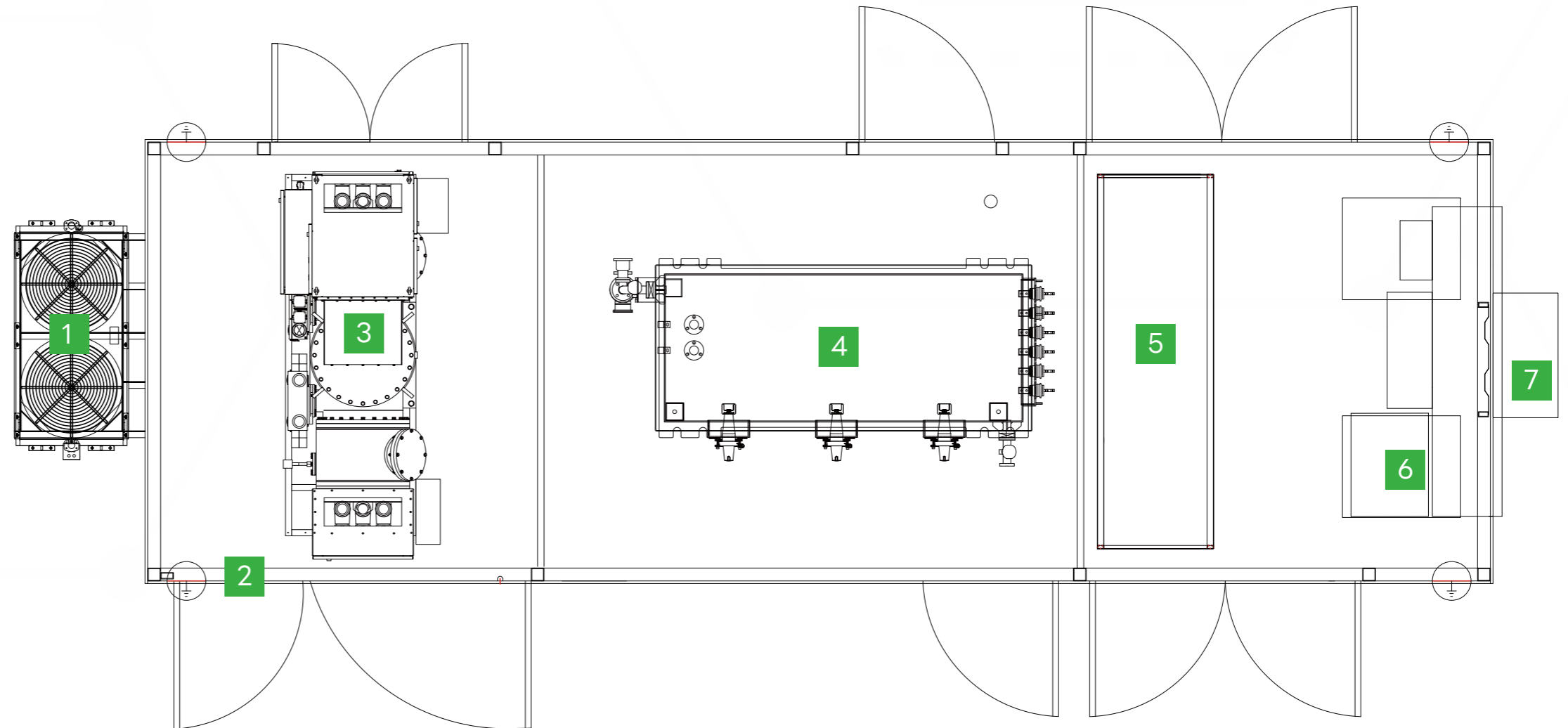

- 1 Forced oil-air cooler
- 2 Prefabricated substation
- 3 72.5 kV Blue GIS
- 4 Transformer
- 5 Low-voltage distribution cabinet
- 6 Auxiliary equipment cabinet
- 7 Air conditioner

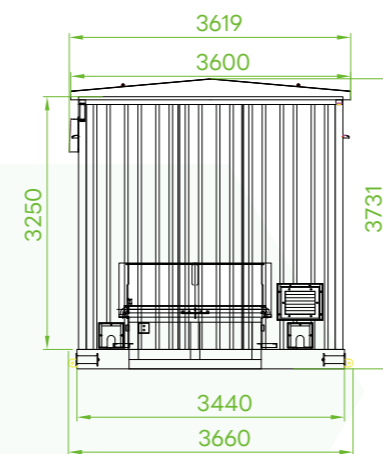
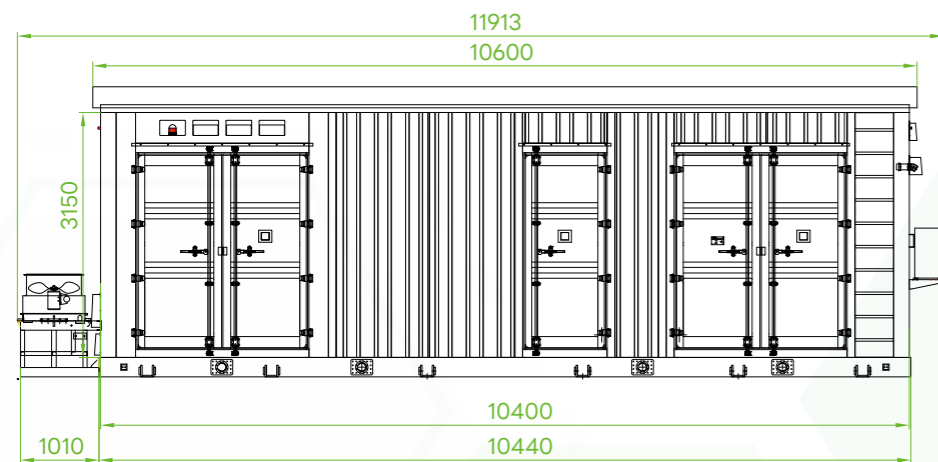

External Dimensions

The kiosk is made from containers, and contains a high-voltage compartment, a transformer compartment, and low-voltage module. The transformer is located in the middle of the kiosk. Featuring a grid-like layout, factory prefabrication, high integration, compact structure, and small footprint, the kiosk can provide different degrees of protection based on different on-site usage environments, and the highest protection degree up to IP66.

# Design and Structure



## 72.5 kV Blue GIS

### Appearance and Technical Features

- Environment friendliness: With a vacuum interrupter for breaking and dry air for insulation, the GIS has zero greenhouse potential (GWP=0) and truly realizes zero-carbon emission;
- Compact structure: The interval is 1040\*2420\*2313 mm only, allowing the GIS to enter and exit through the door and shortening the installation and maintenance time;
- High marine adaptability: High corrosion resistance (up to C5), protection degree (IP55) and seismic performance (AG5) enable the GIS to meet different environmental requirements;
- Modular design: The modular characteristics of the GIS are fully leveraged to achieve flexible design based on the main wiring of the switchgear inside the tower and specific project requirements;
- Low leakage: The overall three-phase common-enclosure structure, with an annual leakage rate of less than 0.1%, allows for maintenance-free operation;
- Cable connection convenience: Type-F bushing plug-in structures are adopted to achieve plug-and-play operation and facilitate installation and replacement, and surge arrester and other accessories with a rear cable insertion design allow for flexible expansion.
- Comprehensive product solutions: the product meets relevant technical standards and the habits and needs of users on both domestic and international markets;
- Small size: The product is small in size, which meets the space layout requirements of both the conventional indoor power distribution room and the outdoor kiosks;
- With an anti-arcing classification of IAC 31.5kA/0.5s, the product is designed with a dedicated arcing pressure relief channel that ensures the safety of operators even in the event of potential arcing incidents.

### Main Wiring Diagram

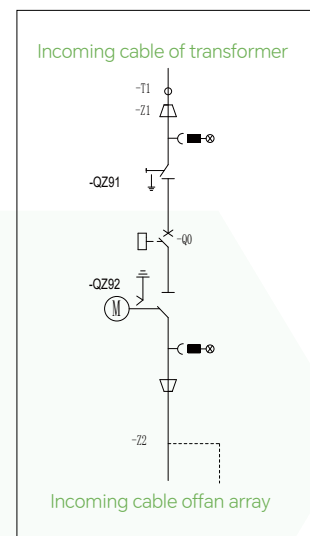
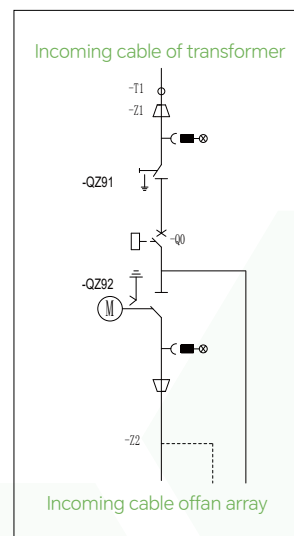
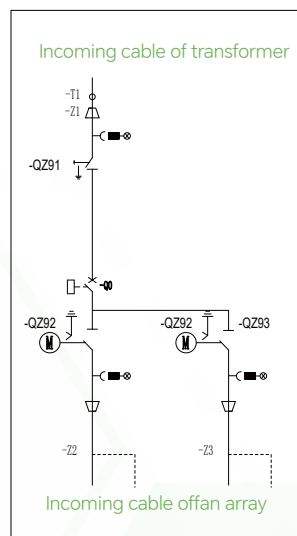



## Transformer

### Appearance and Technical Features

- Ultra-strong short-circuit-resistant structure and elliptical cross-section coil evenly disperse short-circuit impact;
- Efficient overload capacity, reasonable current density, and optimized heat dissipation ensure long-term stable operation;
- High mechanical strength and robust structure provide resistance to external impacts and protect equipment safety;
- Excellent seismic performance and six-point rigid positioning adapt to complex road conditions and ensure transport safety;
- Natural ester or synthetic ester plant oils with high flash points and high-temperature resistance are used as appropriate on site to offer excellent environmental protection properties and environmental adaptability;
- Forced oil-air cooling, water cooling, heat sink or other cooling solutions are optional for transformers;
- Transformer, adopting touchable Type-F bushing plug-in structure, is fully insulated and enclosed for effective protection of personnel safety;



## Transformer

### Technical Features of Forced Oil And Air Cooler

- **Efficient heat dissipation and high load capacity:** Forced oil and air cooling technology drives hot oil to quickly flow through cooling pipes via an oil pump, and the fan forces air convection to improve heat dissipation efficiency;
- **Enhanced heat transfer through structure optimization:** The axial groove or spiral rib structure on the inner wall of the new cooling tube effectively increases the heat dissipation area, and promotes the heat exchange between the hot oil and the wall of the low-temperature oil through the disturbance effect to further enhance heat dissipation efficiency;
- **Stable oil flow control:** The oil pump's start-up acceleration can be dynamically adjusted based on ambient temperature to avoid insulation damage caused by oil flow impact in low-temperature environments;
- **Multiple safety protection:** The oil flow relay monitors the oil flow status in real time and triggers an alarm or trips the circuit when the flow rate is abnormal;
- **High corrosion resistance:** The cooler, with an offshore corrosion resistance category of CX, effectively improves the service life of transformers;
- **Low maintenance costs:** Modular design enables the overall replacement of cooling components;
- **Intelligent control:** The operating status of the fan and the oil pump are automatically adjusted according to oil temperature and load;
- **Low-noise design:** Low-speed fans and sound insulation materials reduce the noise to below 65dB, meet the requirements of residential areas;

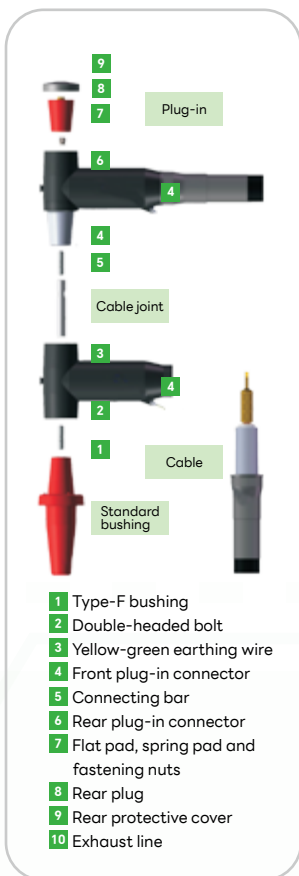

### Technical Features of High-voltage Type-F Bushing, Type-T Shielded Front Plug-In Connectors, Type-T Rear Plug-In Surge Arrester

- Simulation-assisted design is adopted to optimize product performance and structure;
- Well-crafted Type-F bushings, Type-T cable accessories and surge arresters ensure reliable assembly and cooperation;
- Interface dimensions of the Type-F bushings comply with EN50673;
- This product has passed the salt spray and mold test and better met the needs of offshore wind power generation;
- The quality of the product exceeds the technical requirements specified by applicable standards, and its overall performance reaches the international advanced level;



## Low-voltage Switchgear

### Appearance and Technical Features

- The low-voltage module consists of a low-voltage switchgear with a protection degree of above IP30, which prevents accidental contact with live parts when the low-voltage switchgear door is opened, and a protective mesh is installed at the air inlet to meet protection requirements;
- The low-voltage switchgear is connected to the transformer via flexible or rigid busbars in the vertical and horizontal planes, and busbar connections are completed before delivery, requiring no additional on-site construction;
- Each low-voltage switchgear has no less than 34/17 inverter circuit inputs, and the corresponding double-split transformer each low-voltage winding has no less than 17 or inverter circuit inputs. There is an operation hole in the cabinet door to facilitate the operation of ACB in front of the panel; and there is a circuit marking below the operation hole;
- Busbars in the kiosk are made of T2 copper, heat-shrinkable sleeves are provided for busbars in the low voltage switchgear, and the electrical gap between the main circuit and the phase- to-earth circuit meets the insulation requirements to ensure safety;
- The low-voltage module is provided with two air conditioners for efficient ventilation and heat dissipation to ensure the optimal operating environment for components.



## Suggested Foundation Plan

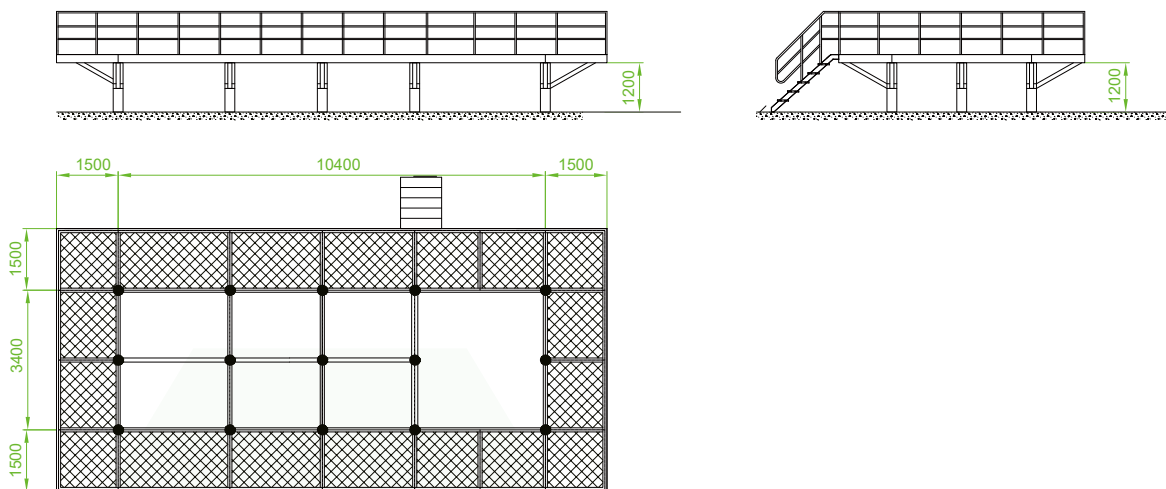

Steel frame foundations or kiosk foundations can be chosen according to on-site conditions and requirements.

## Transport Requirements

- After the kiosk is lifted onto the transport vehicle, angle steel should be welded around the kiosk to limit its position;
- When fixing the kiosk to the transport vehicle, do not use binding ropes to wrap the kiosk with the vehicle, but tie the holes in the bottom profile of the kiosk with the vehicle body;
- Never use binding ropes or steel wires to strangle the kiosk during transport as it may cause paint to peel off or scratches on the surface;
- During the entire transport process, control the start and braking processes smoothly, and avoid emergency braking or abrupt movements;
- Avoid large potholes, and when driving over speed bumps or uneven surfaces, slow down the speed to below 10 km/h;
- When turning or navigating curves, speed should be slowed down to avoid sharp turns at high speeds, and when going around bends, maintain a speed of no higher than 20 km/h;
- During the entire transport process, maintain a speed of no higher than 80 km/h on highways, and avoid sudden acceleration or emergency braking while driving at a constant speed;
- During the whole transport process, the speed limit is 40km/h in the road conditions other than the highway, such as suburbs and lower roads.

## Unloading Requirements

- After transport reaches the destination, first remove the binding ropes securing the bottom of the box to the transport vehicle;
- After binding ropes are removed, welded angle steel around the kiosk should be grounded off to remove the limiting fixtures;
- When unloading the kiosk, lifting straps combined with shackles should be used for lifting, and the use of steel wire ropes for lifting is prohibited.

### Lifting Diagram

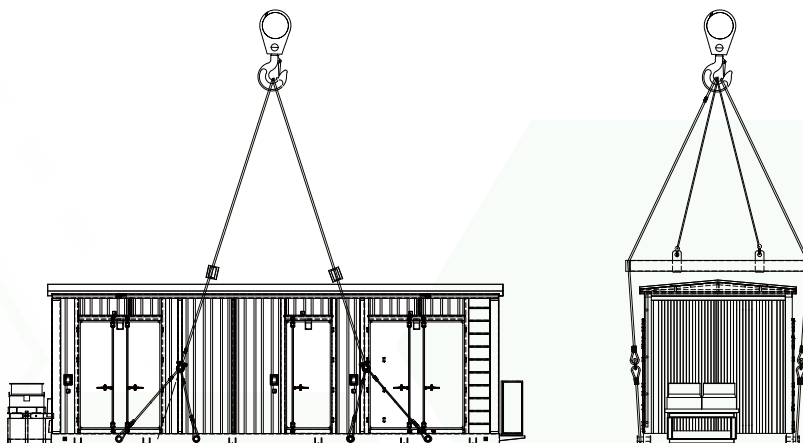



## Lifting Requirements

- Before lifting the kiosk, the angle steel welded to the vehicle body before delivery should be removed to prevent scratching the kiosk during lifting;
- The lifting capacity of the crane should be greater than the nominal weight of the kiosk, allowing for an appropriate safety margin, and the appropriate crane capacity should be selected based on the site location;
- The lifting straps should be of appropriate length, and the hook should generally be 2 to 4 meters above the top cover of the kiosk;
- The kiosk should be lifted with the 8-point lifting approach as shown in the lifting diagram, where the transformer base is lifted from the 8 points other than lifting rings on the top cover or the four corners of the top cover;
- Before the kiosk is lifted, the angle steel welded to the vehicle body before delivery should be removed to prevent scratching the kiosk during lifting, and the kiosk should be lifted into place with care;
- Vibrations should be minimized to avoid damage to electrical components;
- The lifting of the kiosk should be steady to ensure the outer edge of the steel channel on the bottom of the kiosk overlaps entirely with the steel channel on the foundation surface;
- After the kiosk is placed on the foundation, leveling shims (provided by the manufacturer) should be used to prevent deformation that would make the external doors difficult to open, and then all external doors should be tested for opening and closing to prevent deformation;
- Earthing bars should be installed on the earthing bolts (posted with earthing markings) on the steel channel on the bottom of the kiosk, and connected to the earthing network on the foundation to ensure proper earthing of the kiosk;



## Storage Requirements

- The altitude of the storage location should not exceed 2,000 m generally;
- The surrounding air temperature should not be higher than +55 °C or lower than -25 °C;
- Outdoor wind speed should not exceed 20 m/s;
- Relative humidity: The daily average value should not exceed 80%, and the monthly average value should not exceed 70%;
- Ground slope should not exceed 3°;
- The maximum horizontal seismic acceleration should not exceed 0.4 m/s<sup>2</sup>;
- The maximum vertical seismic acceleration should not exceed 0.2 m/s<sup>2</sup>;
- Installation location: The installation location should be free from fire, explosion hazards, severe pollution, chemical corrosion, and intense vibrations.
- The accessories should be properly installed on site and protected from fire, rain, moisture, and frost;
- For equipment damage, missing accessories, or technical documentation during transport, please contact TGOOD's after-sales service team within 24 hours.



**POWERING GLOBAL ENERGY TRANSITION,  
FULFILLING TGOOD COMMITMENT**

**TGOOD ELECTRIC(300001.SZ)**

Address: No.336 Songling Road,Laoshan District,Qingdao,China  
Website:[www.qdtgood.com](http://www.qdtgood.com) E-mail: [info@qdtgood.com](mailto:info@qdtgood.com)  
Tel: +86 532 8908 8929 Fax: +86 532 8908 3066