



HYGN01-20251206



[www.qdtgood.com](http://www.qdtgood.com)

**QINGDAO TGOOD ELECTRIC CO.,LTD.**  
**TGOOD ELECTRIC(300001.SZ)**

Address: No.336 Songling Road,Laoshan District,Qingdao,China

E-mail: [info@qdtgood.com](mailto:info@qdtgood.com)

Tel:+86 532 8908 8929

Fax:+86 532 8908 3066



# TGP-40.5

## Gas-Insulated AC Metal-Enclosed Switchgear



[www.qdtgood.com](http://www.qdtgood.com)



# Company Profile

- > Founded in 2004, TGOOD (Stock Code: 300001) was the first company listed on the Growth Enterprise Board of the Shenzhen Stock Exchange in 2009.
- > The mission of TGOOD is to create the world's top brand of prefabricated power equipment.
- > TGOOD's intelligent modular prefabricated substations has occupied a 60% share of power grid and new energy markets.
- > TGOOD has delivered product solutions to 6300+ customers, and provided 11,000+ prefabricated substations.
- > TGOOD's prefabricated and integrated solutions have been implemented in 50+ countries and regions world wide.

## No.1

The world's No.1 brand of prefabricated substation equipment

## The largest in World

One of the largest supplier for prefabricated substation

## The largest in China

TGOOD is the largest R&D and production base for prefabricated substations in China

## Only in China

The only manufacturer in China achieving digital, technological, specialized, and large-scale production of prefabricated substation

## Champion

MIT manufacturing industry single item champion enterprise

## Four Main Manufacture Factories

Cover an area of more than **780,000** square meters



# Product Overview



The product is an SF<sub>6</sub> gas-insulated AC metal-enclosed switchgear, designed for three-phase AC 50/60Hz single busbar and busbar sectioning, featuring a metal enclosure and fixed installation as an indoor complete set of equipment. It applies to 40.5 kV primary distribution systems for energy control and protection.

## Applicable Standard

- IEC 62271-1 High-voltage switchgear and controlgear –Part 1: Common specifications
- IEC 62271-200 High-voltage switchgear and controlgear –Part 200:AC metal-enclosed switchgear and controlgear for rated voltages above 1 kV and up to and including 52 kV
- GB/T 11022 Common Specifications for High-Voltage Alternating-Current Switchgear and Controlgear Standards
- GB/T 3906 Alternating-Current Metal-Enclosed Switchgear and Controlgear for Rated Voltages Above 3.6 kV and up to and including 40.5 kV

## Product Features

- Independent Ventilation Duct
- Double-Cell Gas Compartment
- Mechanical Interlock Protection
- Independent Instrument Box Structure
- Flexible Combination Solutions of Cabinets with Different Functions



# Table of Contents

<b>Company Profile</b>	<b>02</b>
<b>Product Overview</b>	<b>04</b>
<b>2 Products</b>	<b>06</b>
2.1 Product Overview	06
2.2 Application Scenarios	08
<b>3 Technical Data</b>	<b>09</b>
3.1 Electrical Data - Switchgear	09
3.2 Electrical Data - Circuit Breaker	10
3.3 Electrical Data - Three-position Switch (TPS) Disconnecter and Earthing Switch	10
3.4 Technical Data - Installation of Switchgear	11
<b>4 Product Range</b>	<b>12</b>
4.1 Recommended Scheme	12
4.2 Scheme Description: Circuit Breaker Cabinet	13
4.3 Scheme Description: Isolation Cabinet	14
4.4 Scheme Description: Busbar PT Cabinet	15
4.5 Scheme Description: Busbar Connection Cabinet	16
<b>5 Design and Structure</b>	<b>17</b>
5.1 Panel Design (Example)	17
5.2 Panel Design - Base Interface	18
5.3 Panel Design - Base Interface	19
5.4 Components - Circuit Breaker	20
5.5 Components - TPS Disconnecter - Earthing Switch	21
5.6 Components - Current Transformer	22
5.7 Components - Voltage Transformer	23
5.8 Components - Surge Arrester	24
5.9 Components - Voltage Indicator	25
5.10 Components - SF <sub>6</sub> Gas Density Monitor	26
5.11 Secondary Components - Power monitoring and control devices	27
5.12 Cable Connection Design	28
<b>6 Transport and Installation</b>	<b>30</b>
6.1 Packaging	30
6.2 Lifting	31
6.3 Transport	32
6.4 Delivery	33
6.5 Intermediate Storage	34
6.6 Requirements for On-site Conditions	35
6.7 Installation of Switchgear	35
6.8 Final Installation Operations	35

## 2.1 Product Overview



### Features

TGP-40.5 Switchgear is a complete indoor device that is factory-assembled, type-tested, metal-enclosed, fixed-mounted, SF<sub>6</sub> gas-insulated, designed for three-phase AC 50/60Hz, featuring single busbar and busbar sectioning.

- Rated voltage up to 40.5 kV
- Feeder current up to 3150A
- Busbar current of 3150A

### Typical Applications

The TGP-40.5 switchgear is suitable for use in primary distribution systems:

#### Core scenarios in power systems, for example:

- Substations, power plants
- Power system and utility distribution stations
- Switching stations, mobile power supply stations and substations, and vehicle-mounted mobile substations

#### Industrial sectors, for example:

- Step-up substation of photovoltaic and wind power plant
- Automotive industry and petroleum industry
- Chemical industry and metallurgical industry

#### Rail transport, for example:

- Power supply systems for subways
- Power supply for high-speed rail and airport

#### Special industry sectors, for example:

- Data centers
- Port terminals

### Technology

- Flexible combination solutions of cabinets with different functions
- 304 stainless steel laser-welded gas-insulated gas compartment with excellent corrosion resistance
- Independent power distribution rooms for busbar disconnectors and circuit breakers
- Independent functional modules as functional compartment units
- Dedicated arcing pressure relief channels for upward gas pressure relief
- Special structure of independent instrument boxes
- Independent ventilation channel, significantly improving product heat dissipation capacity
- Earthing switch interlocked with the cable connection compartment door
- Interlocking/mis-operation-proofing protection
- Pluggable cable terminations and surge arresters
- Customizable solid insulated busbar connections

## > Safety

### Personal Safety

- Primary circuit, SF<sub>6</sub> gas-insulated and sealed, with an enclosure that can be safely touched
- The maintenance of the cable connection compartment is permitted only when the feeder is earthed
- Operation can be performed only when the switchgear door is closed
- Logical mechanical interlocks prevent mis-operation
- A voltage indicator is used to check safe isolation from the power supply
- Feeder-side earthing is achieved through the earthing switch and circuit breaker
- Each high-voltage compartment is designed with an arcing pressure relief channel

### Operation Safety

- The high-voltage part of the panel is completely partitioned by different compartments, and these compartments comply with the LSC2 (Loss of Service Continuity Category/Type) as defined in IEC 62271-200
- Configurable protection, monitoring, and control systems
- Logical mechanical interlock prevents mis-operation
- Mechanical interlocking operating holes are equipped with locks to prevent unauthorized access by non-professional personnel

### Maintenance and Service

- When not in use, the product should be stored in a dry environment, shielded from light and rain, with a temperature range of -25 °C to +55 °C
- Real-time support is provided for daily operations: maintenance contracts, technical assistance, spare parts supply, corrective and preventive maintenance, and operation and maintenance training.
- Installation-related service provided:
  - Installation environment analysis
  - Switchgear diagnosis, adaptation, and modification service

### Reliability

- Strict type test and routine test
- Standardized and rigorous CNC production process

### Quality and Environment

- Quality and environmental management systems according to ISO 9001 and ISO 18001

### Service Life

- Under normal operating conditions, the expected service life of TGP Gas-Insulated Switchgear is at least 25 years, taking the switchgear operation and indoor environment into account

# 2 Products

## 2.2 Application Scenarios



New Energy

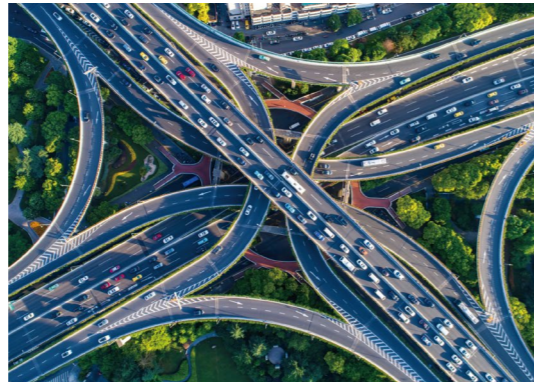

Transport



Petrochemical Engineering



State Grid



Rail Transport



Urban Power Distribution

# 3 Technical Data

## 3.1 Electrical Data - Switchgear

Name	Unit	1250A	2500A	3150A*
Rated voltage	kV	40.5	40.5	40.5
Rated frequency	Hz	50/60	50/60	50/60
Rated short-time power frequency withstand voltage	kV	95	95	95
Rated lightning impulse withstand voltage	kV	185	185	185
Rated current	A	1250	2500	3150
Rated short-time withstand current 3s	kA	31.5	31.5	40
Rated duration of short-circuit	s	3	3	3
Rated peak withstand current	kA	82	82	105
Rated short-circuit breaking current	kA	31.5	31.5	40
Rated short-circuit withstand current of the earthing circuit	kA	31.5	31.5	40
Rated peak withstand current of the earthing circuit	kA	31.5	31.5	40
Rated duration of short-circuit of the earthing circuit	s	2	2	2
Composition of insulating fluid		SF <sub>6</sub>	SF <sub>6</sub>	SF <sub>6</sub>
Mass of insulating fluid	kg	5	7	8.5
Rated filling level for insulation	MPa	0.04	0.04	0.04
Alarm level for insulation	MPa	0.02	0.02	0.02
Minimum functional level for insulation	MPa	0.01	0.01	0.01
Degree of protection	Gas compartment of switchgear	IP67	IP67	IP67
	Enclosure of switchgear	IP4X	IP4X	IP4X
	Compartments of switchgear	IP2X	IP2X	IP2X
Separation level		PM		
Loss of service continuity category		LSC2C		
Internal arcing classification		AFLR		
Arc fault current	kA	31.5	31.5	40
Arc fault duration	s	1	1	1
Ambient temperature	°C	-25~+40		
Dimensions (height * width * depth) (including arcing channel)	mm	2450*600/800*1500	2450*800*1500/1800	2450*900*1800
Standard compliance		IEC 62271-200		

## 3.2 Electrical Data - Circuit Breaker

Name	Unit	1250A	2500A	3150A*
Rated voltage	kV	40.5	40.5	40.5
Rated frequency	Hz	50/60	50/60	50/60
Rated short-time power frequency withstand voltage	kV	95	95	95
Rated lightning impulse withstand voltage	kV	185	185	185
Rated current	A	1250	2500	3150
Rated short-time withstand current	kA	31.5	31.5	40
Rated duration of short-circuit	s	3	3	3
Rated peak withstand current	kA	82	82	105
Rated short-circuit breaking current	kA	31.5	31.5	40
Rated short-circuit making current	kA	82	82	105
DC time constant of rated short-circuit breaking current	ms	45	45	45
Rated line charging breaking current	A	10	10	10
Rated cable charging breaking current	A	31.5	31.5	31.5
Rated operation sequence		0-0.3s-C0-180s-C0		
Class		S1, E2 (list3), C2, M2		
Standard compliance		IEC 62271-100		

\* Forced air cooling solution may be customized based on actual rated current requirements.

\* For high-capacity capacitive currents, a dual-break circuit breaker is optional, capable of interrupting back-to-back capacitive currents up to 1250A.

## 3.3 Electrical Data - Three-position Switch (TPS) Disconnect and Earthing Switch

Name	Unit		
Rated voltage	kV	40.5	40.5
Short-time withstand current 4s	kV	31.5	40
Short-circuit making capacity	E1/E2	E2	E2
Mechanical duration class	M1/M2	M2	M2
Number of auxiliary contacts	-	10NC10NO	10NC10NO

## 3.4 Technical Data - Installation of Switchgear

### Distribution room layout

Please follow the following distribution room layout and switchgear installation steps:  
Installation of Switchgear

### Free-standing arrangement

- 1 row
- 2 rows (face-to-face arrangement)
- Switchgear dimensions
- Floor openings: For related dimensions, refer to the "Panel Design" section

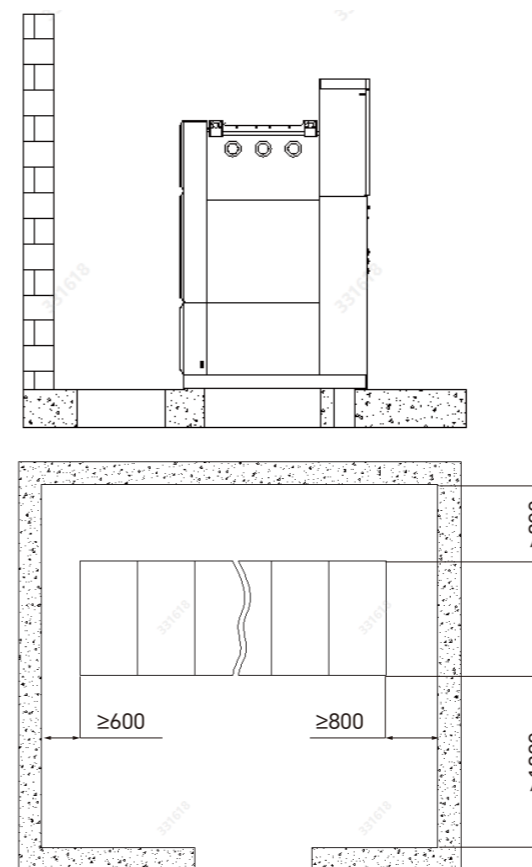

Free-standing arrangement of switchgear

### Pressure relief

- According to the standard design, pressure is relieved upwards
- The gas compartment is equipped with a pressure relief valve
- The gas compartment relieves pressure backward (via the pressure relief channel)

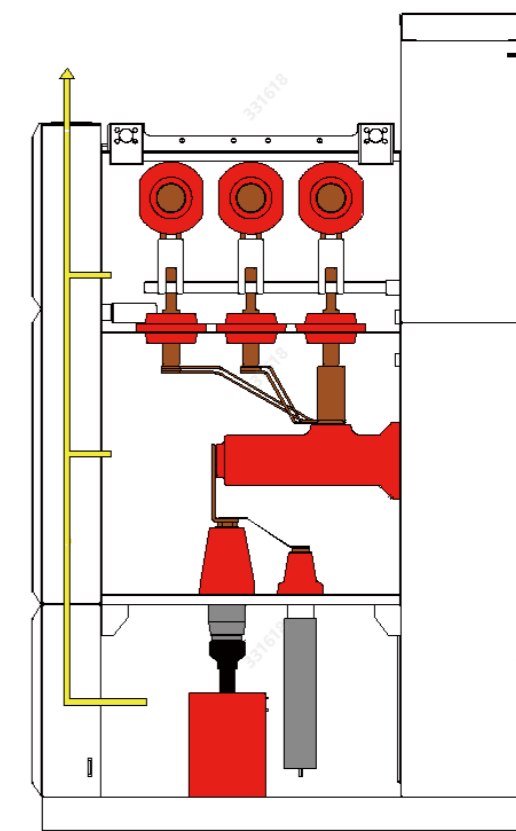

Pressure relief method

## 4.1 Recommended Scheme

TGP-40.5 series includes 6 typical functional application schemes

Name	Circuit Breaker Cabinet	Isolation Cabinet	Busbar PT Cabinet
Primary Scheme			
Function	Connection to main incomer or feeder line	Connection to main incomer line	Connection to busbar voltage transformer

Name	Busbar Connection Cabinet	Metering Cabinet	Direct Connection Lifting Cabinet
Primary Scheme			
Function	Main busbar segmentation, and coupling of two busbar systems	Metering of the busbar system	Connection between the busbar and the busbar connection cabinet

## 4.2 Scheme Description: Circuit Breaker Cabinet

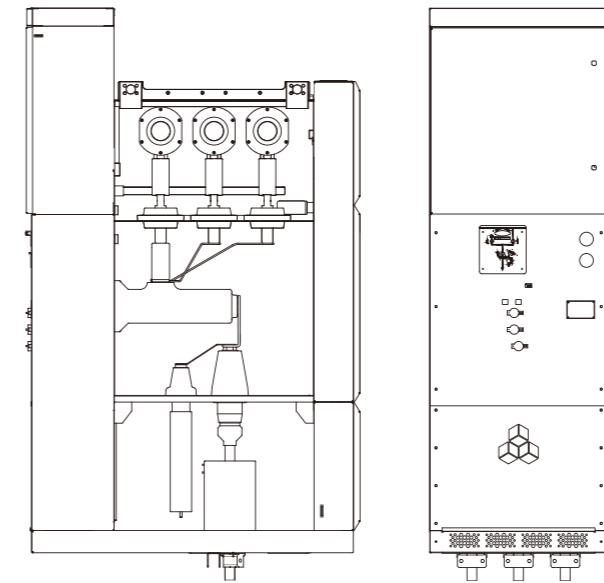

Voltage rating (kV)		40.5		
Rated insulation level				
Power frequency withstand voltage (kV)		95		
Lightning impulse withstand voltage (kV)		185		
Rated current (A)	1250	■	■	
	2500		■	
	3150			■
Breaking capacity (kA)	25	■	■	
	31.5	■	■	
	40			■
Short-time withstand current (kA/3s)	25	■	■	
	31.5	■	■	
	40			■
Dimensions (mm)				
Width (mm)		600	800	900
Height (mm)		2450/2600		
Depth (mm)	Bottom Incoming / Outgoing Line	1500	1800	
	Top Incoming / Outgoing Line/Line PT	1800		

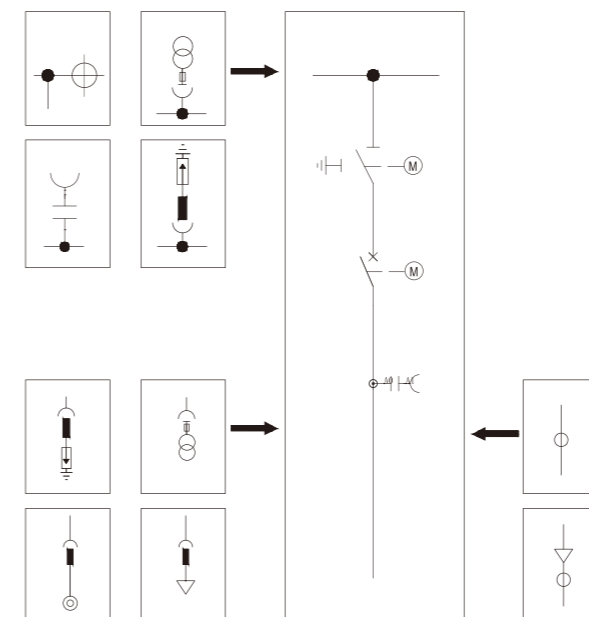

### Function

- Circuit breaker
- Disconnect
- Earthing switch
- Inner cone socket (cable connection)
- Voltage indicator
- Anti-condensation heater
- Low-voltage compartment
- 2# Inner cone socket (surge arrester connection or pt connection)
- Standard height
- Voltage transformer
- Removable fuse
- Fixed fuse
- No fuse
- Bottom wiring
- Top wiring
- Current transformer
- Surge arrester

## 4.3 Scheme Description: Isolation Cabinet

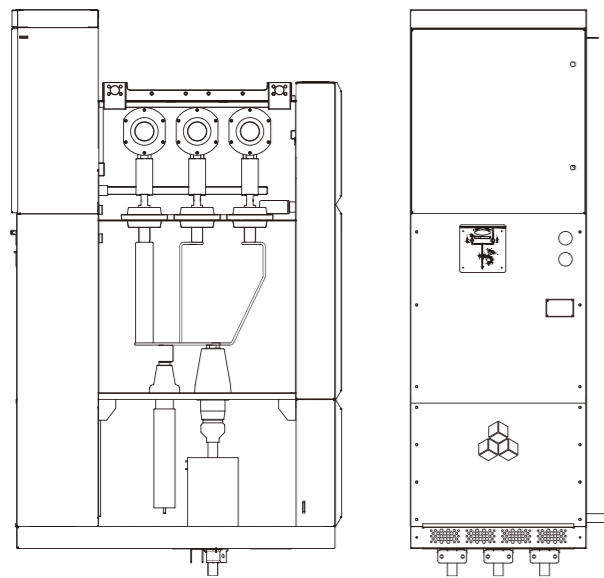

Voltage rating (kV)		40.5		
Rated insulation level				
Power frequency withstand voltage (kV)		95		
Lightning impulse withstand voltage (kV)		185		
Rated current (A)	1250	■	■	
	2500		■	
	3150			■
Breaking capacity (kA)	25	■	■	
	31.5	■	■	
	40			■
Short-time withstand current (kA/3s)	25	■	■	
	31.5	■	■	
	40			■
Dimensions (mm)				
Width (mm)		600	800	900
Height (mm)		2450/2600		
Depth (mm)	Bottom Incoming / Outgoing Line	1500		1800
	Top Incoming / Outgoing Line/Line PT	1800		

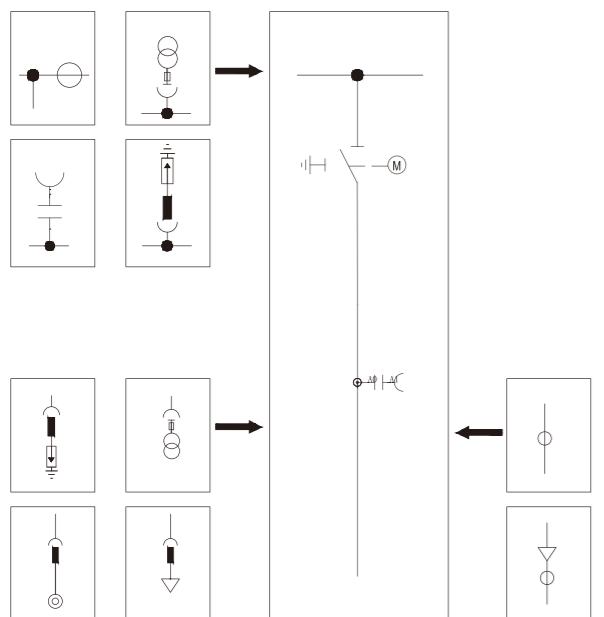

### Function

- Disconnecter
- Earthing switch
- Inner cone socket (cable connection)
- Voltage indicator
- Anti-condensation heater
- Low-voltage compartment
- 2# Inner cone socket (surge arrester connection or pt connection)
- Standard height
- Voltage transformer
- Removable fuse
- Fixed fuse
- No fuse
- Bottom wiring
- Top wiring
- Current transformer
- Surge arrester

## 4.4 Scheme Description: Busbar PT Cabinet

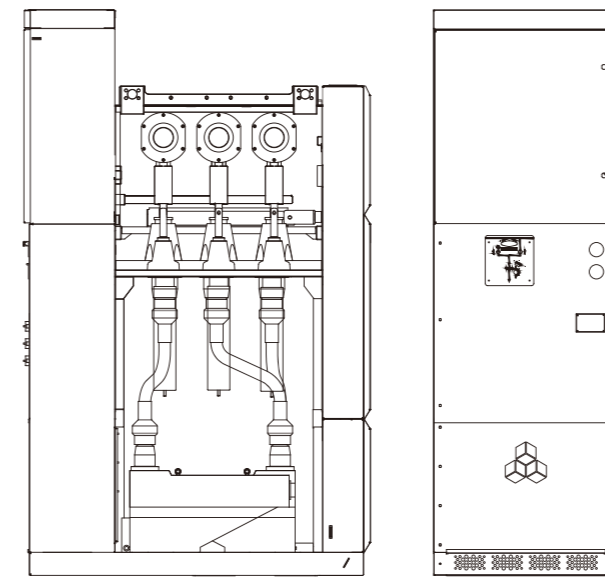

Voltage rating (kV)		40.5	
Rated insulation level			
Power frequency withstand voltage (kV)		95	
Lightning impulse withstand voltage (kV)		185	
Short-time withstand current (kA/3s)	25	■	
	31.5	■	
	40	■	
Dimensions (mm)			
Width (mm)	800		
Height (mm)	2450/2600		
Depth (mm)	1500		

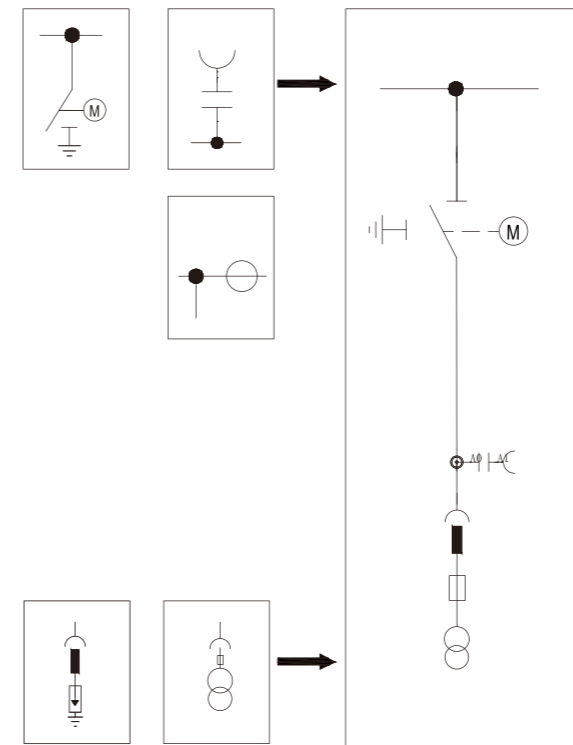

### Function

- Disconnecter
- Earthing switch
- Inner cone socket (PT cable connection)
- Voltage indicator
- Anti-condensation heater
- Low-voltage compartment
- 2# Inner cone socket (surge arrester connection or pt connection)
- Standard height
- Voltage transformer
- Removable fuse
- Fixed fuse
- No fuse
- Current transformer
- Surge arrester

# 4 Product Range

## 4.5 Scheme Description: Busbar Connection Cabinet

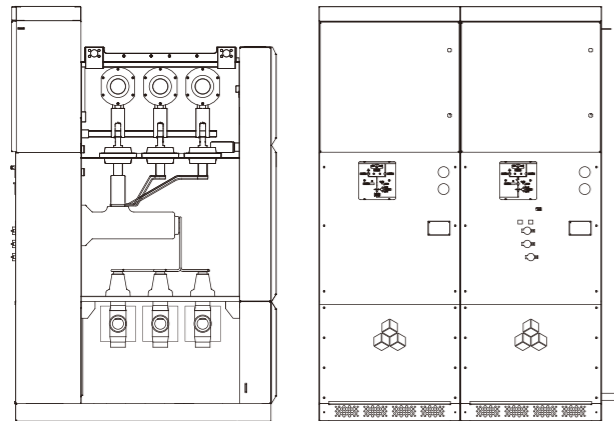

Voltage rating (kV)		40.5	
Rated insulation level			
Power frequency withstand voltage (kV)		95	
Lightning impulse withstand voltage (kV)		185	
Rated current (A)	1250	■	■
	2500		■
	3150		■
Breaking capacity (kA)	25	■	■
	31.5	■	■
	40		■
Short-time withstand current (kA/3s)	25	■	■
	31.5	■	■
	40		■
Dimensions (mm)			
Width (mm) (single unit dimensions)	600	800	900
Height (mm)	2450/2600		
Depth (mm)	1500		

\* The busbar connection cabinet consists of two gas-insulated switchgear units, including busbar sectioning cabinet and busbar isolation cabinet

### Function

- Circuit breaker
- Disconnecter
- Earthing switch
- Outer cone busbar socket
- Voltage indicator
- Anti-condensation heater
- Low-voltage compartment
- 2# Inner cone socket (surge arrester connection or pt connection)
- Standard height
- Voltage transformer
- Removable fuse
- Fixed fuse
- No fuse
- Current transformer
- Surge arrester

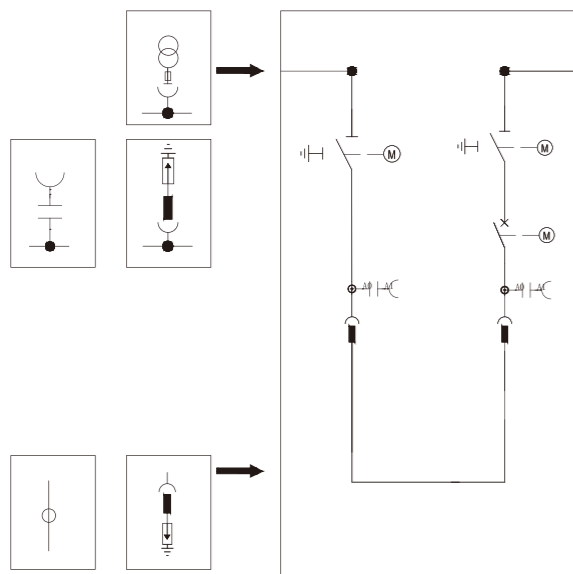

# 5 Design and Structure

## 5.1 Panel Design (Example)

### Basic Structure

The switchgear is divided into 6 compartments:

- A. Low-voltage (LV) compartment
- B. Busbar disconnecter gas compartment
- C. Operating mechanism compartment
- D. Circuit breaker gas compartment
- E. Cable connection compartment
- F. Pressure relief channel compartment

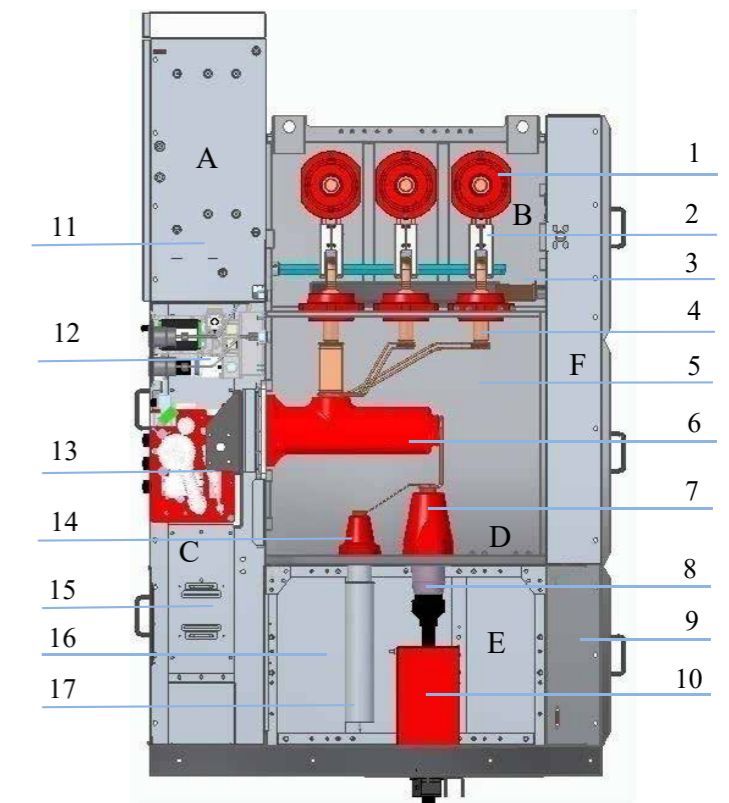
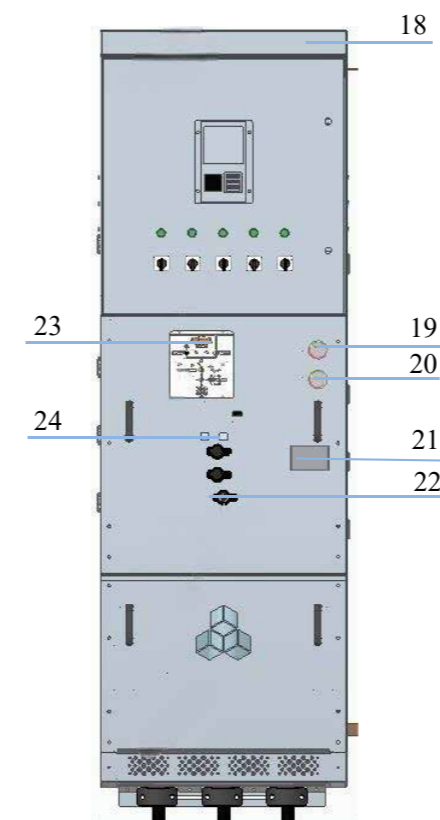

- 1. Busbar connection bushing between cabinets
- 2. TPS disconnecter
- 3. Busbar disconnecter gas compartment
- 4. Upper and lower compartment insulators
- 5. Circuit breaker gas compartment
- 6. Fixed-mounted circuit breaker
- 7. 3# inner cone socket
- 8. 3# cable termination
- 9. Pressure relief channel
- 10. Line-side CT
- 11. Low-voltage compartment
- 12. TPS disconnecter operating mechanism
- 13. Circuit breaker operating mechanism
- 14. 2# inner cone socket
- 15. Mechanism operating compartment
- 16. Cable connection compartment
- 17. Surge arrester
- 18. Top trim
- 19. Gas density relay for TPS gas compartment
- 20. Gas density relay for circuit breaker gas compartment
- 21. Nameplate
- 22. Circuit breaker operating holes
- 23. TPS disconnecter plate
- 24. Circuit breaker open/close indicator

## 5.2 Panel Design - Base Interface

### Basic Requirements:

- The upper surface of the foundation steel should be 5-10 mm higher than the floor surface of finished distribution room or kiosk
- The flatness tolerance of the foundation steel is  $\pm 1$  mm/1 m
- The straightness tolerance of the foundation steel is  $\pm 1$  mm/1 m
- The height difference between adjacent steel beams is  $\pm 1$  mm
- The depth of the cable trench must meet the minimum bending radius requirement for the primary cable in one go. When laying cables, reserve a certain length of cable and ensure it is 1.5 meters above the floor surface of the distribution room or kiosk
- The product is fixed to the foundation steel and adjusted to level before being bolted for fixed connection
- Cutting out of foundation and switchgear coordination, refer to design drawings (switchgear bottom frame design)

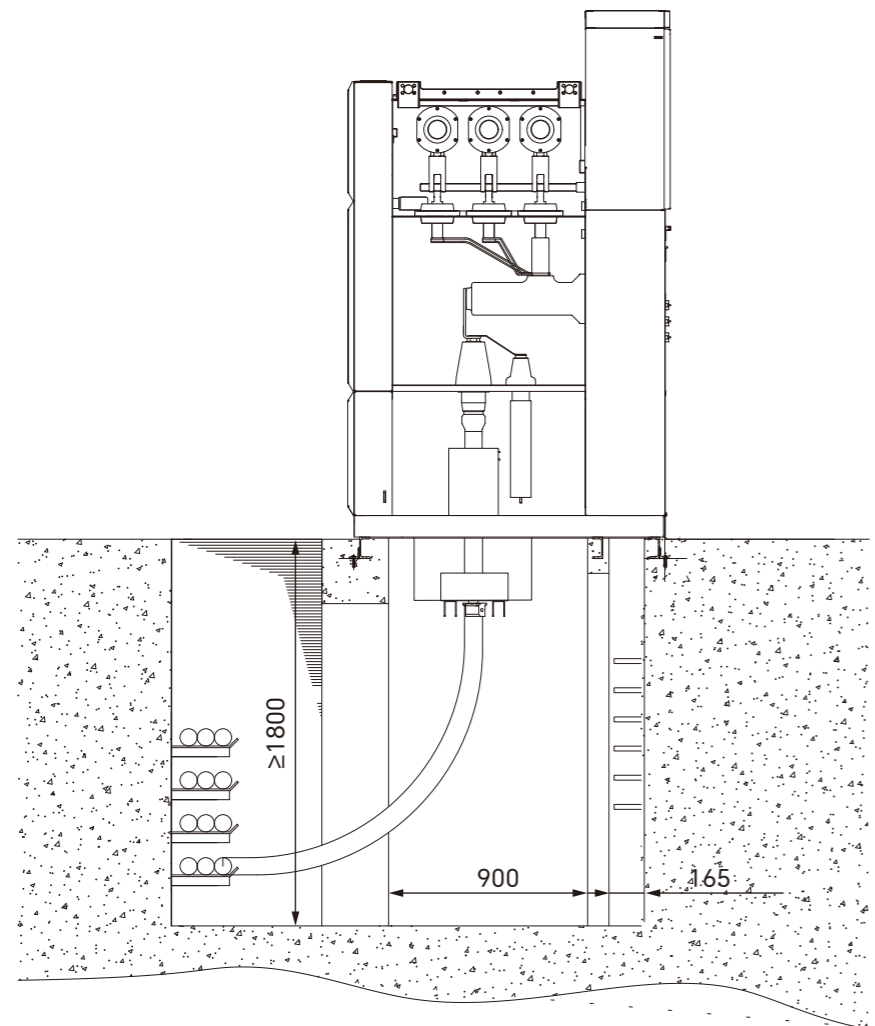

## 5.3 Panel Design - Base Interface

900 Wide Cabinet

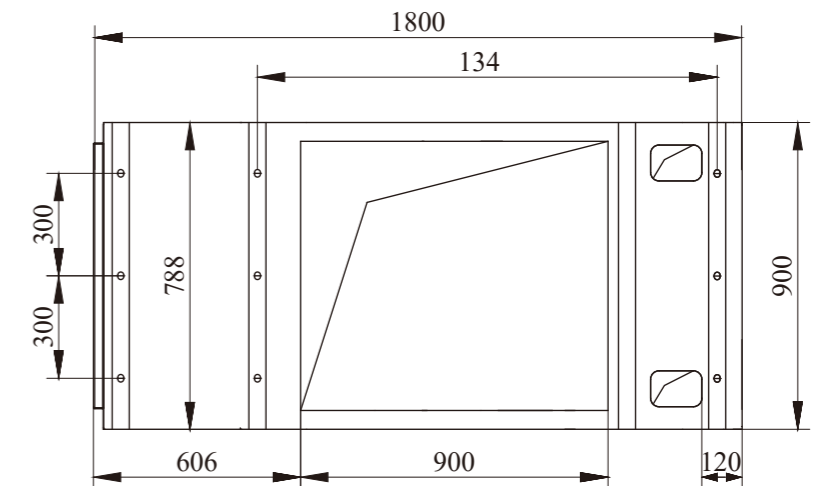

800 Wide Cabinet

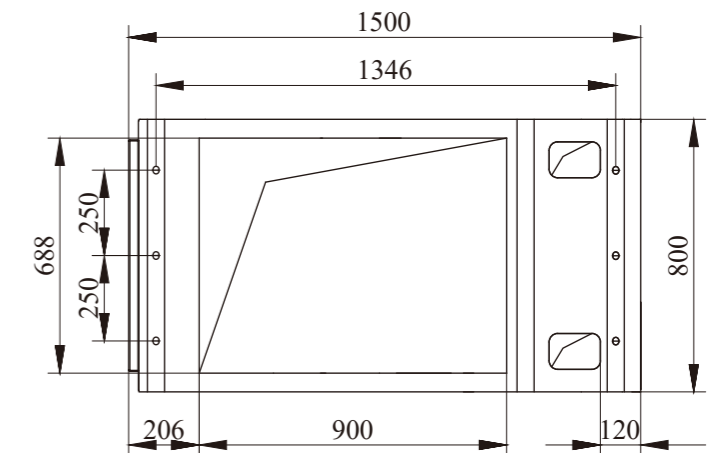

600 Wide Cabinet

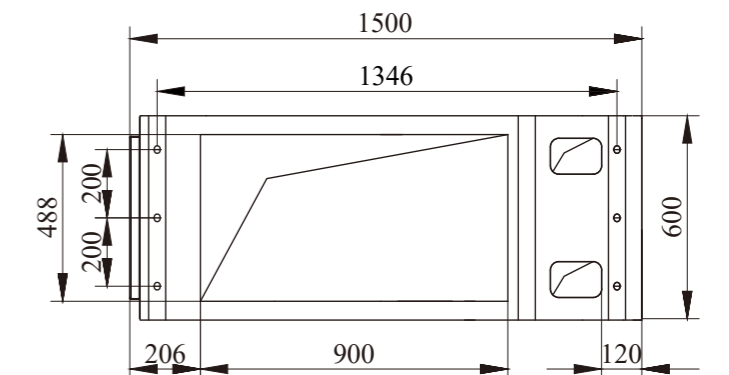

## 5.4 Components - Circuit Breaker

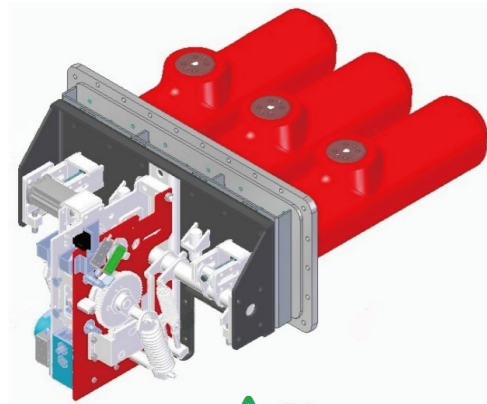

The product complies with GB/T 1984 and IEC 62271-100

Circuit breaker switch rating			
Function	Type	Standard	Performance
Switch rating	M2	IEC62271-100 GB/T1984	10,000 times mechanically without maintenance
	E2		10,000 times rated normal current, 30 times short-circuit breaking current
	C2		Extremely low re-ignition rate

Operating time	
Closing time	25-75ms
Opening time	20-60ms
Arcing time	≤15ms
Energy storage time	≤20s

### Structural layout:

- A/B/C three-phase arranged horizontally from left to right
- Installation and commissioning outside the switchgear, with the entire unit fixed-mounted in place
- Vacuum interrupter located within the switchgear gas compartment
- Gas compartment and vacuum interrupter separated by a metal bellows
- For interrupting large-capacity capacitive currents, a double-break circuit breaker is optional

### Trip-free mechanism:

- The vacuum circuit breaker is fitted with a trip-free mechanism
- The product complies with GB/T 1984 and IEC 62271-100

### Operating cycle and operating mechanism:

- The switching operation of the vacuum circuit breaker is related to the configured operating mechanism

### Motor-operated mechanism:

- For auto-reclosing (K)
- For synchronized closing and rapid load transfer (U)

### Operating mechanism features:

- Installed outside the gas compartment and the mechanism box of the control board
- Spring energy storage operating mechanism for 10,000 operating cycles
- Option: Spring energy storage operating mechanism for 20,000 operating cycles

### Operating mechanism functions:

- Motor-operated mechanism or manual operating mechanism
- Closing spring is charged electrically and manually
- Close by Close push button or a closing coil
- Open by Open push button or an opening coil
- Option: open by a secondary opening coil

### Mechanical interlock:

- Three-position switch mechanical interlock
- Three-position switch can only be operated with vacuum circuit breaker in the OPEN position

## 5.5 Components - TPS Disconnecter - Earthing Switch

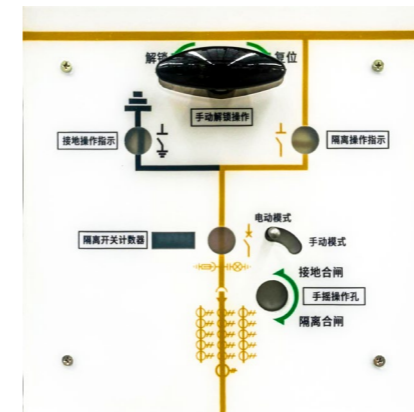

Free-standing arrangement of switchgear

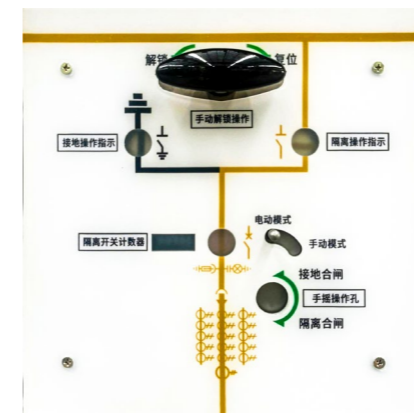

Disconnecter CLOSED and Circuit Breaker CLOSED

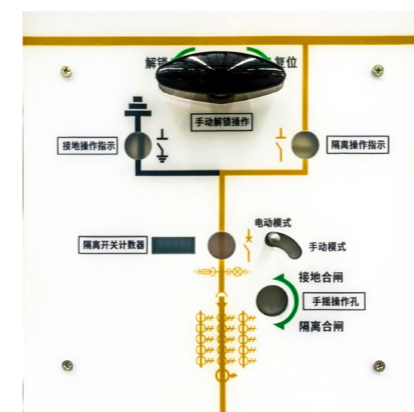

Earthing Switch CLOSED and Circuit Breaker CLOSED

### Features

- Rated current up to 3150A
- Up to 5000 operating cycles for the disconnecter
- Up to 5000 operating cycles for the earthing switch
- Operating shaft and moving contacts with common center of rotation and reliable switch position on front plate
- Gas-tight bushings separate the busbar and circuit breaker gas compartment underneath the disconnecter contacts
- Maintenance-free under normal operating conditions in accordance with GB/T11022 and IEC62271-1

### Switch Positions

- “Close”, “Open”, “Earthed” or “Ready to Earth”
- Closing: Moving contacts connected with the busbar: Main circuit closed between busbar and circuit breaker
- Opening: Main circuit open between busbar and circuit breaker, and isolating distances withstand test voltages
- Ready-to-Earth: Contact blades connected with the earthing contact
- Earthed: Circuit breaker closed for feeder earthing

### Operating Mechanism

- Only permissible operations possible due to logical mechanical interlocks
- Mechanical position indicator
- Common operating shafts for the “isolation/earthing” function
- With manual operating mechanism
- With motor operating mechanism
- Same operations of the “CLOSE” or “OPEN” functions

### Interlock

- Select permitted operations via the control door mechanically interlocked with the vacuum circuit breaker (the disconnecter can only be operated when the circuit breaker is in the OPEN position)
- Remove the operating handle only after the switch operation is completed
- Option: Manual operating holes can be equipped with locks

## 5.6 Components - Current Transformer

The conventional current transformer is used to provide current input for metering, measurement, or protection and controlling devices, capable of measuring primary currents from 10A to 3150A, in compliance with IEC 61869-2.

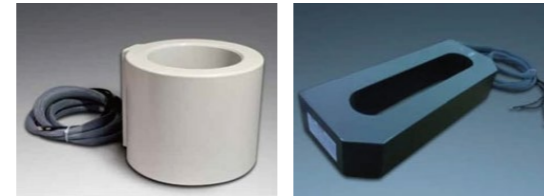

### Features

- Single-pole and ring core current transformers
- Free of dielectric stress epoxy-resin parts
- Insulation class E
- Inductive type
- Certified
- Independent of environmental effects
- Secondary connection via terminal blocks in the low-voltage compartment
- Epoxy-resin insulated

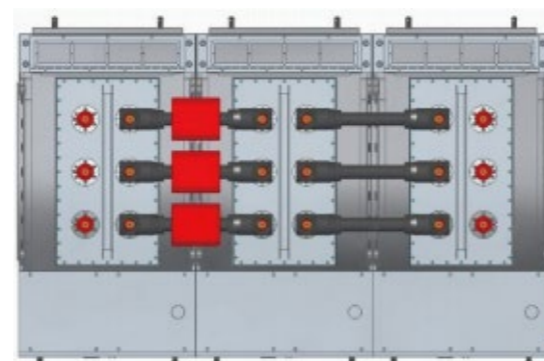
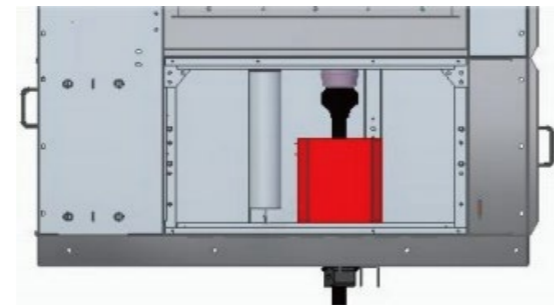

### Installation

- Arranged outside/inside the primary gas compartment (optional)
- Installed on the line side (cable connection compartment)
- Installed on the busbar side (between cabinets)
- Installation example shown below

## 5.7 Components - Voltage Transformer

A voltage transformer is a device used to transform the voltage on a line or busbar, primarily to reduce high voltage to a low voltage suitable for measurement and protection. It is widely used in power systems to measure line voltage, power, and electrical energy, and to protect valuable equipment, motors, and transformers on the lines. Its design complies with IEC 61869-3.



### Features

- Single-pole, plug-in design
- Connection system with plug-in connectors compliant with EN50181
- Inductive type
- Metal enclosure allowing safe contact
- Certified
- Independent of environmental effects
- Secondary connection via terminal blocks in the low-voltage compartment
- Epoxy-resin insulated
- With or without fuse

### Installation

- Arranged in the gas compartment at the primary side
- Directly installed on the busbar side (without a disconnect)
- Installed as separate busbar PT cabinet
- Installation example shown below

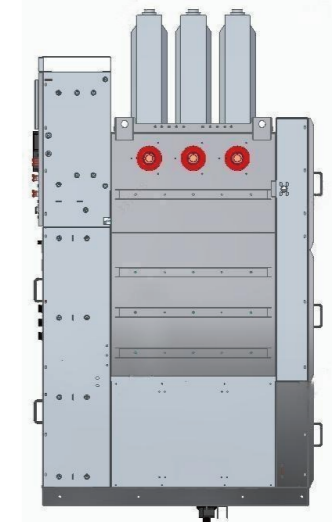
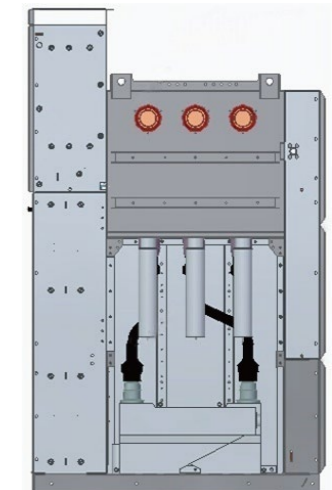

## 5.8 Components - Surge Arrester

The surge arrester utilizes the excellent nonlinear volt-ampere characteristics of zinc oxide, allowing a very small current (microampere or milliampere level) to flow through the arrester at normal operating voltage. When overvoltage occurs, the resistance drops sharply, releasing the overvoltage energy to protect objects.

### Features

- Single-pole, plug-in design
- Connection system with plug-in connectors compliant with EN50181
- Metal enclosure allowing safe contact
- Certified
- Independent of environmental effects
- Epoxy-resin insulated



## 5.9 Components - Voltage Indicator

The high-voltage voltage indicator is installed in locations where it needs to show whether the device is live, preventing electrical mis-operation, in compliance with IEC 61958.

### Features

- Installed on the busbar side or the line side
- Offering locking contact for high-voltage electrical appliances
- Compatible with 50Hz and 60Hz
- External testing socket
- Compliant with IEC standards
- Supporting external voltage testing and phase verification testing
- Having self-inspection function
- Standard product configuration



## 5.10 Components - SF<sub>6</sub> Gas Density Monitor

SF<sub>6</sub> pressure gauge is used to monitor the gas density inside the gas compartment of the TGP-40.5 switchgear, and it is capable of withstanding harsh outdoor environmental conditions. It promptly issues alarm signals, interlock signals, or overpressure signals in response to SF<sub>6</sub> gas leaks in electrical devices, to ensure their safe operation.

### Features

- Offer pressure value color zones
- Replenish gas in the gas compartment without removing the meter
- Give low pressure alarm and interlock signal
- Provide optional pressure display units
- Offer optional communication function
- Provide at most three pairs of signal outputs
- Enable on-site verification of the gauge possible
- Have automatic temperature compensation
- Provide each gas compartment with a gas pressure density relay



## 5.11 Secondary Components - Power monitoring and control devices

This energy meter is an economical and efficient high-performance instrument, which can operate as an independent device or be integrated into the power monitoring system (please consult us for details).

### Basic monitoring functions:

- Billing class: Current/voltage accuracy 0.2%
- Embedded storage module: For energy consumption analysis
- Embedded clock/calendar: Support for time/data tagging

### Application flexibility:

- Standalone meter and display module
- Direct connection voltage up to 600V (higher voltage requires a voltage transformer)

### Other devices:

Applicable to devices such as line monitors for medium voltage (MV) and low voltage (LV) networks, with main functions including:

- Comprehensive power monitoring
- Power quality analysis and recording
- Input/output control



## 5.12 Cable Connection Design

### Power Cables

- The power cable enters the switchgear cable connection compartment through the foundation from below, and passes through a rubber reducer ring (the reducer ring can be adjusted to fit the cable diameter)
- Cable terminations must be installed to the cable core as per the manufacturer's instructions
- Various connection methods are designed based on the number of parallel cables, rated current, and short-circuit current values
- In all cases, the cable shield earthing is achieved through a earthing busbar near the fixed cable clip, with the earthing busbar connected to earth potential

### Important Notes:

- Internal connections usually adopt single-core plastic insulated cables
- Special cables (such as three-core cables, solid insulated busbars, and other special insulated cables) need to be confirmed through consultation

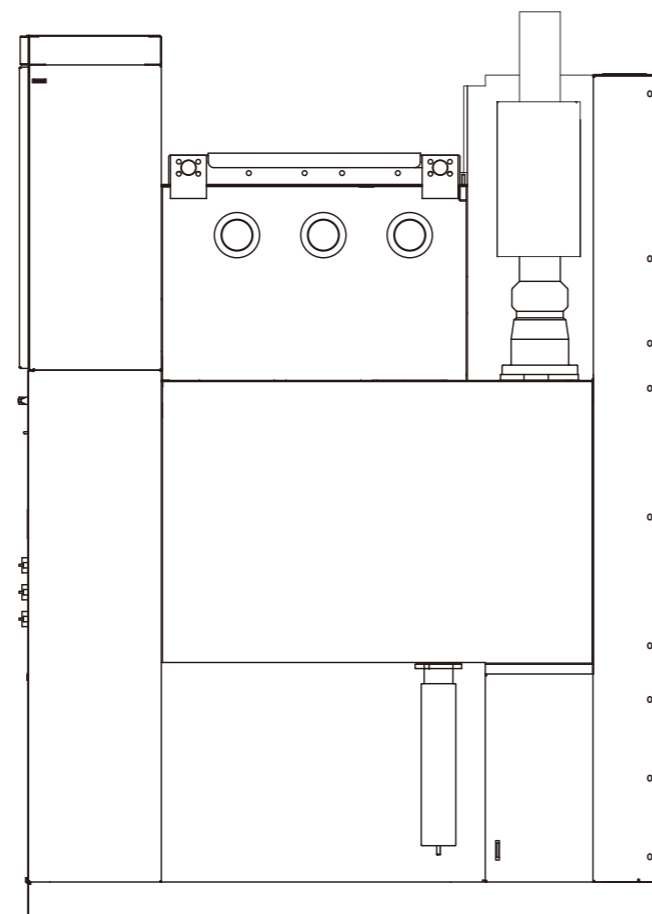

Top Incoming/Outgoing Line of Solid Insulated Busbars

## 5.12 Cable Connection Design

### TGP-40.5 cable connection:

TGP-40.5 can use fully insulated cables or fully solid insulated busbars, so the switchgear is configured with a pluggable cable termination (cable termination or solid insulated busbar adapter configured according to the order agreement). The cable terminations/ solid insulated busbar adapter connects to the gas compartment with a matching socket.

- For cable connection, a maximum of three cables can be installed per phase, with a maximum current of 2500A
- For a current of 2500A and above, solid insulated busbars are recommended, paired with 4# inner cone sockets
- 3# cable sockets are preferred, with 3# inner cone sockets compatible with cable specifications of 500 mm<sup>2</sup> or below. 2# inner cone sockets are optional, compatible with cable specifications of 240 mm<sup>2</sup> or below
- 4# solid-insulated busbars are preferred, with 4# inner cones and solid insulated busbars capable of handling a maximum current of 3150A

### Power cable installation process:

- Power cables must first be threaded through CT, then cut to length and stripped of the insulation layer
- The rubber reducer ring must be adjusted according to the cable diameter before being inserted into the cable
- The cable termination must be prepared and installed to the cable core according to the manufacturer's instructions
- The cable termination must be connected to the pre-fabricated connection busbar via pressure relief devices
- The cable must be properly earthed
- The segmented base plate cover must be installed
- The reducer ring must be moved downward so that it fits into the corresponding groove in the base sealing plate, to seal the cable channel
- The cable must be fixed with pre-fabricated cable clips

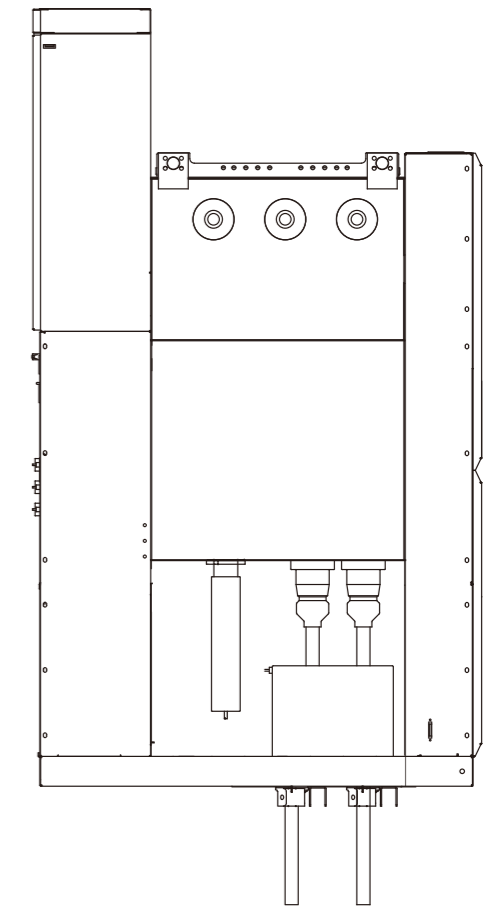

Bottom Incoming /Outgoing Line of Cable

## 6.1 Packaging

The switchgear is packaged according to the specific requirements of the customer. During international transport, the switchgear must be:

- Placed on a wooden pallet and fixed with bolts
- Sealed with polyethylene film
- Sealed with aluminum foil welding
- Placed desiccant bags for transport in the panel
- Included humidity indicator
- Sealed with fumigated wooden box board
- Stored for a maximum period of: 6 months
- Desiccants are provided inside the switchgear for more effective moisture prevention
- Busbars are not pre-installed, and their materials, fasteners, and accessories must be packaged separately

The use of desiccant bags complies DIN 55473, as detailed below:

- Blue indicator: Container is dry
- Pink indicator: Container is damp (relative humidity exceeds 40%)

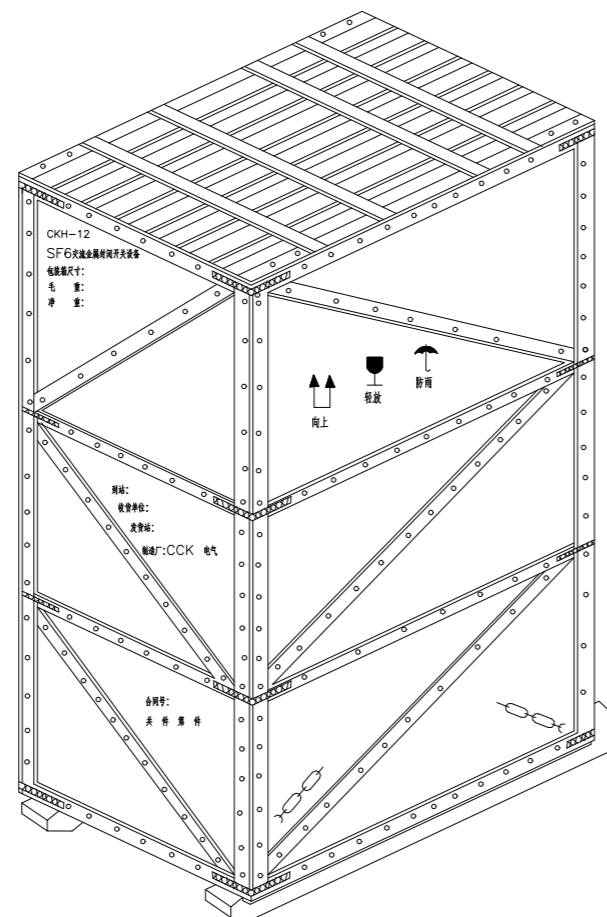

## 6.2 Lifting

- Handling tools can include cranes or forklifts
- When using a crane for lifting, the rope position should follow the lifting marks on the packaging box enclosure, or use the lifting ring on the switchgear, but the lifting rope angle should not exceed 60° (refer to the lifting illustration for specific details)
- During lifting, the switchgear must not tilt. When using a forklift, the entire switchgear must be placed entirely on the forklift tines
- If necessary, ropes should be used to secure the switchgear to the forklift to prevent it from toppling

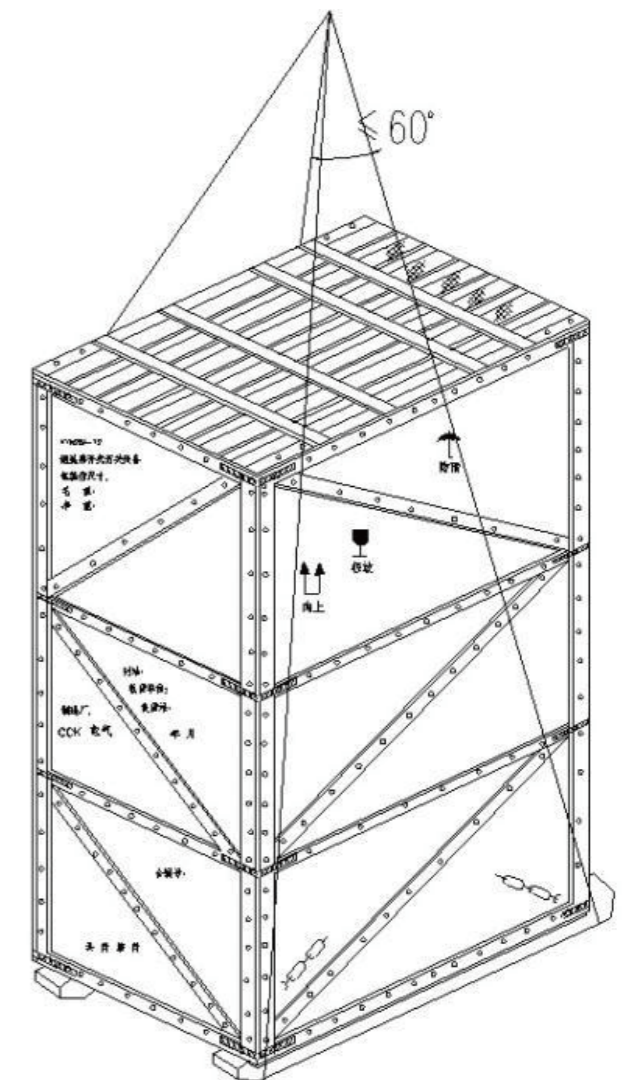

## 6.3 Transport

The transport method should be determined based on the final destination, and customer requirements must be followed. For international transport, switchgears are shipped with appropriate packaging based on current conditions (e.g., packaging suitable for sea transportation).



Marks Required for Transport

During transport, a detailed packing list with a bill of lading will be provided to the carrier to ensure smooth customs clearance at the destination port.

### Transportation must comply with the following guidelines:

- Ensure the switchgear should be always upright during the transport
- Provide four ring-type lifting lugs provided for lifting with straps or steel cables
- Ensure the switchgear should be transported inside a sealed container
- Do not stack panels on top of each other
- Always keep the container dry
- Use only lifting equipment that meets the rated capacity of the switchgear panel

\* Consideration must be given to its high center of gravity characteristics. Loading and unloading operations can only be performed when all personnel protection and material preventive measures have been implemented, and cranes, forklifts, and/or manual hydraulic hand trucks are used.

### Crane loading/unloading requirements:

- Lifting ropes and shackles that conform to the load capacity must be provided (opening width  $\geq 30$  mm, fastening hole diameter 30 mm)
- Lifting ropes and crane hook connection lines must maintain an angle of at least  $60^\circ$  with the horizontal plane
- Lifting ropes must be ensured in good condition
- Crane operators must have appropriate qualifications
- The crane must be located on stable ground and accurately positioned

## 6.4 Delivery

1. Upon arrival, the switchgear and components must be immediately checked for signs of transport damage:

- Any visible external damage must be confirmed by the driver on the freight documentation
- Efforts must be made to check for moisture and its harmful effects
- Based on insurance claim conditions, any damage must be reported in writing to the delivery transport agent within two weeks
- Hidden damage can only be detected after removing the packaging material. Claims for subsequent transport damage must be reported to the manufacturer within one week of delivery

2. All components and accessories must be cross-checked against the packing list, with key items including:

- Components
- Tools
- Spare Parts

3. The manufacturer's serial number on the delivery note must match the serial number on the switchgear nameplate exactly

4. The external unloading of the switchgear must follow the operating markings on the packaging crate

## 6.5 Intermediate Storage

The switchgear is packaged for transport and storage when it leaves the factory.

**The switchgear can be stored for up to 6 months under the following conditions:**

- The switchgear is placed outdoors on a dry and covered ground or moisture-proof insulating material
- After inspection for transport damage, the original packaging must be restored to its delivery condition
- The switchgear should be stored in a clean, dry, and well-ventilated environment
- **The storage area must prevent the following factors from causing equipment deterioration:**
  - a. Water
  - b. Water vapor
  - c. Salt-containing air
  - d. Any type of contaminants
  - e. Microorganism

### Precautions:

- The switchgear must be kept upright during storage
- Stacking switchgears is strictly prohibited
- The switchgear is not weatherproof, and outdoor storage is prohibited (rainwater and moisture may cause irreversible damage)
- For short-term storage ( $\leq 2$  weeks), the switchgear must be covered with a dustproof plastic sheet
- Do not walk on top of the switchgear (which may cause damage to the pressure relief device)

### Additional requirements for long-term storage:

- Use heat-sealing moisture-proof cloth to wrap the panel (with the maintenance door must be retained as a visual window)
- Regularly replace desiccant bags
- Periodically inspect the integrity of the packaging seals

### Operational procedures after unpacking the equipment:

- Perform basic maintenance tasks
- Test the minimum operating threshold of the electrical control coils ( $\geq 85\%$  of rated voltage)

### Installation qualification requirements:

- To ensure the best installation process and quality standards, on-site installation of the switchgear must be performed by qualified personnel who have received professional training, or supervised throughout the operation by a responsible engineer

## 6.6 Requirements for On-site Conditions

**Before installing TGP-40.5, the power distribution room must meet the following requirements:**

- All civil works must be completed, including the lighting system and structure power supply access
- The room must have a closing function and a dry environment, and be equipped with ventilation facilities
- All cable laying and pre-installation work (wall penetrations, cable trenches, etc.) must be completed before power and control cables are introduced into the switchgear

**Installation requirements for special structures:**

**When the switchgear has structures like a secondary busbar compartment installed at the top, any of the following conditions must be met:**

- The ceiling height must be sufficient to accommodate the full stroke of the pressure relief baffle
- A top pressure relief channel system must be installed

## 6.7 Installation of Switchgear

### Installation steps:

- Transport the switchgears to the pre-designated installation location in the sequence shown on the switchgear layout diagram
- Align the switchgear with the steel-reinforced concrete with foundation rails according to the assembly diagram
- Connect each switchgear using fasteners
- Align each switchgear with the foundation frame one by one to ensure accurate positioning and vertical alignment (the vertical deviation of the panel edge must not exceed 2 mm, with particular attention to the front), and connect the switchgear with bolts

**If more than ten switchgears are involved, it is recommended to start the installation from the center**

- After the switchgear is assembled, connect it to the base frame by welding/bolting

## 6.8 Final Installation Operations

- Inspect the painted areas of the switchgear for damage and re-coat if necessary
- Inspect the bolt connections and tighten them as required, with particular attention to the bolts installed on-site for the busbar and earthing systems
- Thoroughly clean the switchgear
- Remove all foreign objects from inside the switchgear
- Correctly reposition any parts like cover plates that were removed during the installation and wiring process
- Check the smoothness of the interlocking mechanisms, and lubricate again if necessary
- Please refer to the TGP-40.5AC Gas Insulated Metal-Enclosed Switchgear Installation and Operation Manual for the installation of the whole cabinet