

HYGN01-202501020



www.qdtgood.com

QINGDAO TGOOD ELECTRIC CO.,LTD.
TGOOD ELECTRIC(300001.SZ)

Address: No.336 Songling Road,Laoshan District,Qingdao,China

E-mail: info@qdtgood.com

Tel:+86 532 8908 8929

Fax:+86 532 8908 3066



TGS SF₆

Insulated AC

Metal-enclosed Switchgear



www.qdtgood.com



Company Profile

- > Founded in 2004, TGOOD (Stock Code: 300001) was the first company listed on the Growth Enterprise Board of the Shenzhen Stock Exchange in 2009.
- > The mission of TGOOD is to create the world's top brand of prefabricated power equipment.
- > TGOOD's intelligent modular prefabricated substations has occupied a 60% share of power grid and new energy markets.
- > TGOOD has delivered product solutions to 6300+ customers, and provided 11,000+ prefabricated substations.
- > TGOOD's prefabricated and integrated solutions have been implemented in 50+ countries and regions world wide.

No.1

The world's No.1 brand of prefabricated substation equipment

The largest in World

One of the largest supplier for prefabricated substation

The largest in China

TGOOD is the largest R&D and production base for prefabricated substations in China

Only in China

The only manufacturer in China achieving digital, technological, specialized, and large-scale production of prefabricated substation

Champion

MIT manufacturing industry single item champion enterprise

Four Main Manufacture Factories

Cover an area of more than **780,000** square meters



Product Overview



The product is an SF₆ AC metal-enclosed switchgear. It applies to secondary distribution systems below 24 kV for electric energy control and protection.

Applicable Standard

- IEC 62271-1 High-voltage switchgear and controlgear –Part 1: Common specifications
- IEC 62271-200 High-voltage switchgear and controlgear –Part 200:AC metal-enclosed switchgear and controlgear for rated voltages above 1 kV and up to and including 52 kV
- GB/T 11022 Common Specifications for High-Voltage Alternating-Current Switchgear and Controlgear Standards
- GB/T 3906 Alternating-Current Metal-Enclosed Switchgear and Controlgear for Rated Voltages Above 3.6 kV and up to and Including 40.5 kV

Product Features

- Independent of Environmental Effects
- Independent Compartment Functional Unit
- Logical Mechanical Interlocking Protection
- Special Independent Instrument Box Structure
- Flexible Combination Solutions of Cabinets with Different Functions



Table of Contents

Company Profile	02
Product Overview	04
2 Products	06
2.1 Product Overview	06
2.2 Application Scenarios	08
3 Technical Data	09
3.1 Electrical Data - Switchgear	09
3.2 Electrical Data - Circuit Breaker	10
3.3 Electrical Data - Load-breaker	11
3.4 Electrical Data - Load-breaker - Fuse Combination Device	11
3.5 Installation of Switchgear	12
4 Product Range	13
4.1 Recommended Scheme	13
4.2 Cubicle Description - C Load switch unit	14
4.3 Cubicle Description - V Circuit breaker unit	15
4.4 Cubicle Description - F Load switch-fuse combined electrical unit	16
4.5 Cubicle Description - D Cable connection unit	17
4.6 Cubicle Description - Cp PT unit with load switch	18
4.7 Cubicle Description - M Metering unit	19
5 Design and Structure	20
5.1 Panel Design (V-Cabinet Example)	20
5.2 Panel Design (C-Cabinet Example)	21
5.3 Panel Design (F-Cabinet Example)	22
5.4 User Configurable Combination Cabinet Solutions(Non-Expandable Dimensions and Weight for TGS)	23
5.5 User Configurable Combination Cabinet Solutions(Expandable Dimensions and Weight for TGS)	24
5.6 Panel Design (Example) - Compartment	25
5.7 Panel Design (Example)	26
5.8 Description of Control Panel Function	27
5.9 Composition	28
5.10 Current Transformer	29
5.11 Bushing Current Transformer	29
5.12 Busbar current transformer	30
5.13 Voltage transformer	30
5.14 Voltage Indicator	31
5.15 High-voltage HRC fuse assembly	32
6 Transport and Installation	33
6.1 Packaging	33
6.2 Transport	34
6.3 Delivery	35
6.4 Unpacking	36
6.5 Precautions	37
6.6 Requirements for On-site Conditions	38
6.7 Base Interface	39

2.1 Product Overview



Features

TGS SF₆ AC Metal-enclosed Switchgear has passed type testing, suitable for indoor installation, three-phase metal-clad single busbar switchgear:

- Rated voltage up to 24 kV
- Feeder current up to 630A
- Busbar current of 630A

Typical Applications

TGS switchgear can be used for secondary distribution systems in harsh environments, such as:

Core scenarios in power systems, for example:
Ring network equipment for power supply and public facilities, user load stations, and switching stations

Industrial sectors, for example:

- Wind farms, solar power plants, and hydroelectric power stations
- Water treatment plants
- Airports, train stations, and subway stations
- Lightweight mining facilities
- Hotels, shopping centers, office buildings, commercial centers, etc

Technology

- Flexible combination solutions of cabinets with different functions
- 304 stainless steel welded gas compartment with excellent corrosion resistance
- Interlocking/mis-operation-proofing protection
- Special structure of independent instrument boxes
- Independent functional compartment units
- Downward relief of gas pressure
- Independent of environmental effects

Service Life

- Under normal operating conditions, the expected service life of TGS Gas-Insulated Switchgear is at least 20 years, taking the switchgear operation and indoor environment into account

Compact Structure

- Effectively utilize existing substations and distribution rooms
- Save valuable urban land
- Lower costs for new projects

> Safety

Personal Safety

- The protection degree of high-voltage live components in the main circuit of the switchgear is IP67, with the enclosure protection degree of IP4X
- The gas-sealed high-voltage panel is safe to touch
- The operating mechanism is safe to operate outside the switchgear
- Cable terminations are all covered with shielded earthing layers
- Internal arcing test can withstand up to 20kA/1s
- Load-breaker and earthing switches are three-position switches (TPS) with interlocks between them to prevent mis-operation
- There is reliable mechanical interlocking between the cable connection compartment door and the load-breaker, and operation is allowable only when the switchgear cable connection compartment door is closed
- Voltage indicators ensure safe isolation from the power supply
- High-voltage fuses and cable terminations can only be accessed when the earthing switch is closed
- The earthing switch is a fast earthing switch for safe operation

Maintenance and Service

- When not in use, the product should be stored in a dry environment, shielded from light and rain, with a temperature range of -25 °C to +40 °C
- Real-time support is provided for daily operations: maintenance contracts, technical assistance, spare parts supply, corrective and preventive maintenance, and operation and maintenance training
- **Installation-related service provided:**
 - Installation audit
 - Switchgear diagnosis, adaptation, and modification service

Reliability

- Strict type test and routine test
- Standardized and rigorous CNC production process

Quality and Environment

- Quality and environmental management systems according to ISO 9001 and ISO 18001

2 Products

2.2 Application Scenarios



New Energy

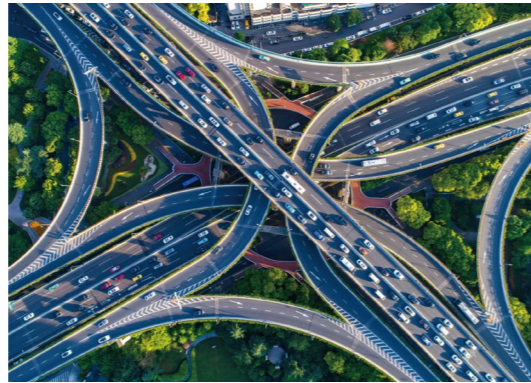

Transport



Petrochemical Engineering



State Grid



Rail Transport



Urban Power Distribution

3 Technical Data

3.1 Electrical Data - Switchgear

Name	Unit	Data		
Rated voltage	kV	12	24	
Rated frequency	Hz	50/60	50/60	
Rated short-time power frequency withstand voltage	Phase-to-phase, phase-to-earth	kV	28	50
	Isolating distance	kV	32	60
Rated lightning impulse withstand voltage	Phase-to-phase, phase-to-earth	kV	75	125
	Isolating distance	kV	85	145
Rated continuous current	A	630	630	
Rated short-time withstand current	kA	20/25	20	
Rated duration of short-circuit	s	3/1	3	
Rated peak withstand current	kA	65	50	
Rated short-circuit breaking current	kA	20	20	
Rated short-circuit withstand current of the earthing circuit	kA	20/25	20	
Rated peak withstand current of the earthing circuit	kA	52/65	52	
Rated duration of short-circuit of the earthing circuit	s	3/1	3	
Composition of insulating fluid		SF ₆	SF ₆	
Mass of insulating fluid	kg	4	4	
Rated filling level for insulation	MPa	0.14	0.14	
Alarm level for insulation	MPa	0.13	0.13	
Minimum functional level for insulation	MPa	0.13	0.13	
Degree of Protection	Panel enclosure		IP3X	
	Compartment		IP2X	
	Gas compartment		IP67	
Partition class			PM	
Loss of service continuity category			LSC2B	
IAC Class			AFLR	
Arc fault current	kA	20		
Arc fault duration	s	1		
Ambient temperature	°C	-25~+40		
Dimensions (height * width * depth)	mm	See pages 14-19 below		
Standard compliance		IEC 62271-200		

3.2 Electrical Data - Circuit Breaker

Name	Unit	Data		
Rated voltage	kV	12	24	
Rated frequency	Hz	50/60	50/60	
Rated short-time power frequency withstand voltage	Phase-to-phase, phase-to-earth	kV	28	50
	Isolating distance	kV	32	60
Rated lightning impulse withstand voltage	Phase-to-phase, phase-to-earth	kV	75	125
	Isolating distance	kV	85	145
Rated continuous current	A	630	630	
Rated short-time withstand current	kA	20/25	20	
Rated duration of short-circuit	s	3/1	3	
Rated peak withstand current	kA	65	52	
Rated short-circuit breaking current	kA	20	20	
Rated short-circuit making current	kA	65	52	
DC time constant of rated short-circuit breaking current	ms	45	45	
Rated line charging breaking current	A	10	10	
Rated cable charging breaking current	A	10	10	
Rated operation sequence		0-0.3s-C0-180s-C0		
Class		E2, C2, M2		
Standard compliance		IEC 62271-100		

3.3 Electrical Data - Load-breaker

Name	Unit	Data		
Rated voltage	kV	12	24	
Rated frequency	Hz	50/60	50/60	
Rated short-time power frequency withstand voltage	Phase-to-phase, phase-to-earth	kV	28	50
	Isolating distance	kV	32	60
Rated lightning impulse withstand voltage	Phase-to-phase, phase-to-earth	kV	75	125
	Isolating distance	kV	85	145
Rated continuous current	A	630	630	
Rated short-time withstand current	kA	20/25	20	
Rated duration of short-circuit	s	3/1	3	
Rated peak withstand current	kA	65	52	
Rated short-circuit making current	kA	65	52	
Class		E2, C2, M2		
Standard compliance		IEC 62271-103		

3.4 Electrical Data - Load-breaker - Fuse Combination Device

Name	Unit	Data	
Rated voltage	kV	12	24
Rated frequency	Hz	50/60	50/60
Rated continuous current	A	125	125
Rated short-circuit breaking current of fuse	kA	31.5	31.5
Transfer current	A	1500	1300
Standard compliance		IEC 62271-105	

3 Technical Data

3.5 Installation of Switchgear

Distribution room layout

Please follow the following distribution room layout and switchgear installation steps: Installation of Switchgear

Pressure relief

According to standard design, pressure is relieved downwards

Wall-standing arrangement

- 1 row
- 2 rows (face-to-face arrangement)

Option: Free-standing arrangement

- Switchgear dimensions
- Floor openings: For related dimensions, see page 35
- Pressure relief direction and related pressure relief space

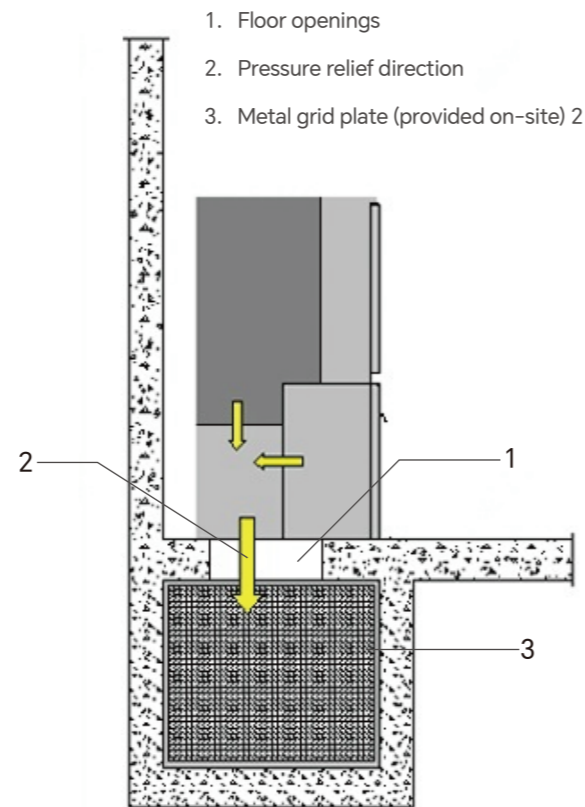
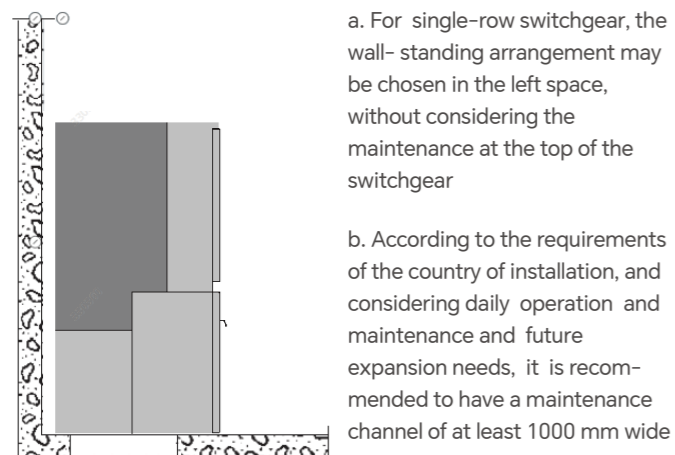

Wall-standing arrangement of switchgear

Installation of switchgear, with downward pressure relief channel (standard)

4 Product Range

4.1 Recommended Scheme

Name	C Load switch unit	V Circuit breaker unit	F Load switch-fuse combined electrical unit
Function	Connection to incomer or feeder lines	Connection to incomer or feeder lines	Make transformer protection
Single Line Diagram			

Name	D Cable connection unit	Cp PT unit with load switch	M Metering unit
Function	Connect the busbars of adjacent cabinets	Connect PT to the busbar for metering	Metering equipment electricity consumption
Single Line Diagram			

4.2 Cubicle Description - C Load switch unit

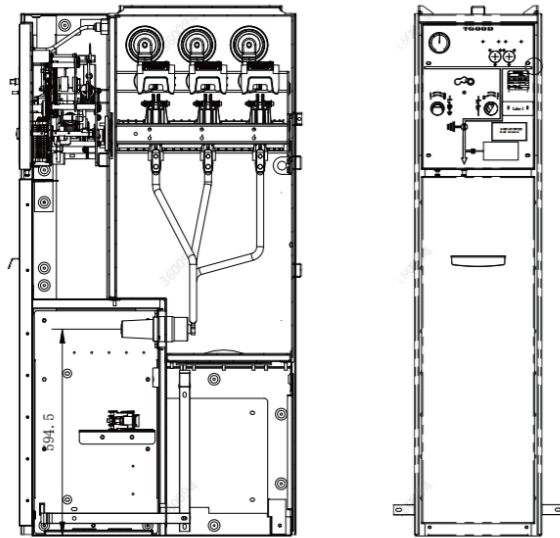

Rated voltage (kv)		12	24
Rated insulation level			
Power frequency withstand voltage 50 Hz - 1 min (rms kV)		28	50
Lightning impulse withstand voltage 1.2/50 μ s (kV peak)		75	125
Rated current (A)	630	■	■
Breaking capacity (kA)	20	■	■
	25	■	
Short - time (kA/s) With stand current	20/3s	■	■
	25/1s	■	
Dimensions (mm)			
Width (W)		368	
Depth (D)		792	
Height (H)	Instrument box is not included	1502	
	Instrument box	300/350/400	

Function

- 630A internal busbar
- TPS load-breaker/earthing switch
- TPS single -spring operating mechanism with two independent operating shafts for the load-breaker and earthing switch
- Load-breaker and earthing switch position indicators
- Outgoing bushings with a horizontal layout at the front
- Voltage indicator indicating live bushing
- SF₆ Gas pressure gauge (only one per SF₆ gas compartment)
- Expansion of reserved external busbar
- Motorized operation of load-breaker
- Ring core current transformer
- Pluggable surge arrester
- Low-voltage compartment at the top of switchgear

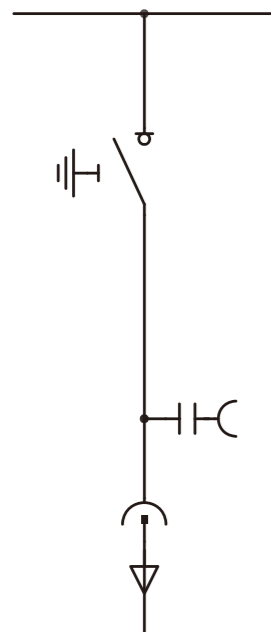

4.3 Cubicle Description - V Circuit breaker unit

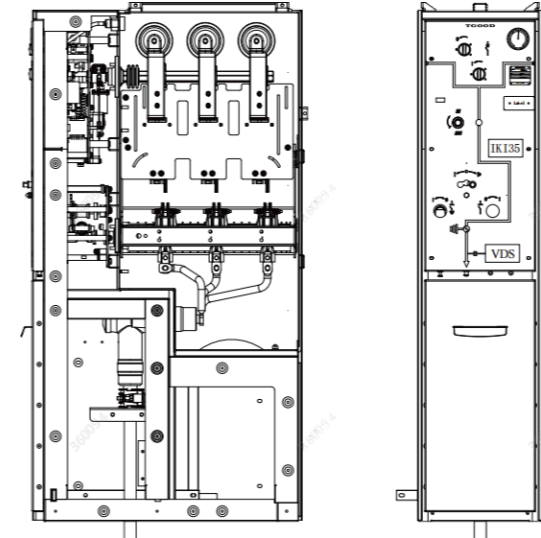

Rated voltage (kv)		12	24
Rated insulation level			
Power frequency withstand voltage 50 Hz - 1 min (rms kV)		28	50
Lightning impulse withstand voltage 1.2/50 μ s (kV peak)		75	125
Rated current (A)	630	■	■
Breaking capacity (kA)	20	■	■
	25	■	
Short - time (kA/s) With stand current	20	■	■
	25/1s	■	
Dimensions (mm)			
Width (W)		368	
Depth (D)		792	
Height (H)	Instrument box is not included	1502	
	Instrument box	300/350/400	

Function

- 630A internal busbar
- Vacuum circuit breaker and spring-operated mechanism
- TPS disconnecter/earthing switch
- TPS single -spring operating mechanism with two independent operating shafts for disconnectors and earthing switches
- Vacuum circuit breaker and TPS position indicators
- Outgoing bushings with a horizontal layout at the front
- Voltage indicator indicating live bushing
- SF₆ Gas pressure gauge (only one per SF₆ gas compartment)
- Reserved for external busbar expansion
- Motorized operation of vacuum circuit breaker
- Ring core current transformer
- Pluggable surge arrester
- Low-voltage compartment at the top of switchgear
- Microcomputer protection device

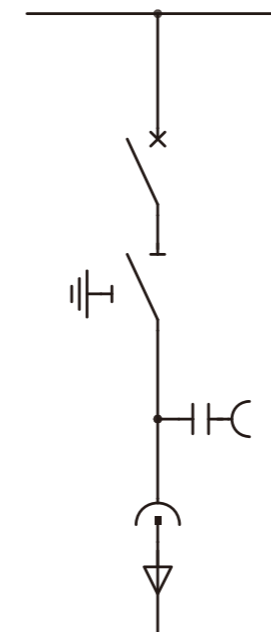

4.4 Cubicle Description - F Load switch-fuse combined electrical unit

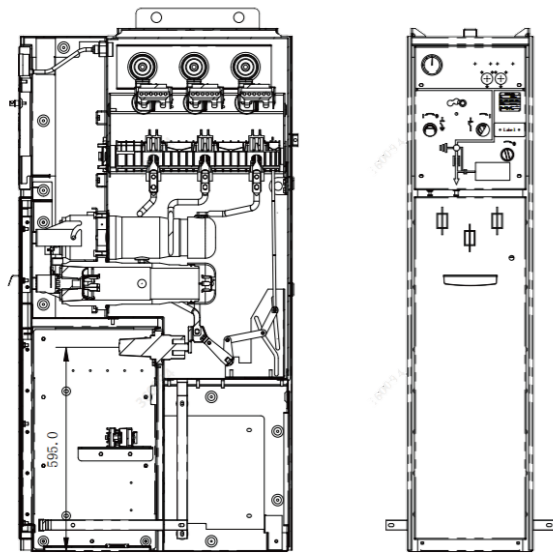

Rated voltage (kV)		12	24
Rated insulation level			
Power frequency withstand voltage 50 Hz - 1 min (rms kV)		28	50
Lightning impulse withstand voltage 1.2/50 μ s (kV peak)		75	125
Rated current (A)	125	■	■
Breaking capacity (kA)	31.5	■	■
Dimensions (mm)			
Width (W)		368	
Depth (D)		792	
Height (H)	Instrument box is not included	1502	
	Instrument box	300/350/400	

Function

- 630A internal busbar
- TPS load-breaker, with mechanical interlocking between earthing switches at fuse start and fuse end
- TPS spring-operated mechanism with two independent operating shafts for the load-breaker and earthing switch
- Load-breaker and earthing switch position indicators
- Outgoing bushings with a horizontal layout at the front
- Voltage indicator indicating live bushing
- SF₆ Gas pressure gauge (only one per SF₆ gas compartment)
- Reserved for external busbar expansion
- Motorized operation of load-breaker
- Fuses and fuse trip indicators
- Parallel trip coils
- Ring core current transformer
- Pluggable surge arrester
- Low-voltage compartment at the top of switchgear

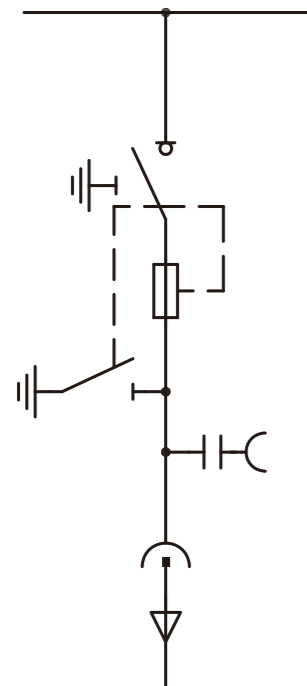

4.5 Cubicle Description - D Cable connection unit

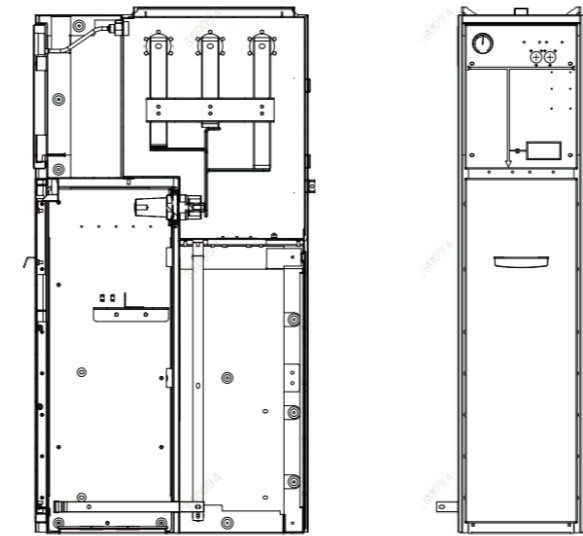

Rated voltage (kV)		12	24
Rated insulation level			
Power frequency withstand voltage 50 Hz - 1 min (rms kV)		28	50
Lightning impulse withstand voltage 1.2/50 μ s (kV peak)		75	125
Rated current (A)	630	■	■
Short - time (kA/s) With stand current	20/3s	■	■
	25/1s	■	
Dimensions (mm)			
Width (W)		368	
Depth (D)		792	
Height (H)	Instrument box is not included	1502	
	Instrument box	300/350/400	

Function

- 630A internal busbar
- Outgoing bushings with a horizontal layout at the front
- Voltage indicator indicating live bushing
- SF₆ Gas pressure gauge (only one per SF₆ gas compartment)
- Reserved for external busbar expansion
- Ring core current transformer
- Pluggable surge arrester
- Low-voltage compartment at the top of switchgear

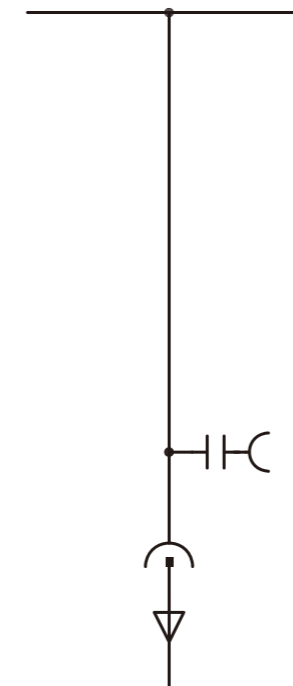

4.6 Cubicle Description - Cp PT unit with load switch

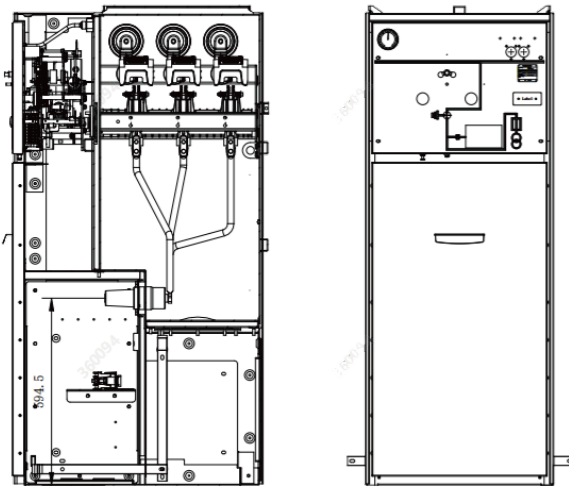

Rated voltage (kv)		12
Rated insulation level		
Power frequency withstand voltage 50 Hz - 1 min (rms kV)		28
Lightning impulse withstand voltage 1.2/50 μ s (kV peak)		75
Rated current (A)	630	■
Dimensions (mm)		
Width (W)	600	
Depth (D)	792	
Height (H)	Instrument box is not included	1502
	Instrument box	300/350/400

Function

- 630A internal busbar
- TPS load-breaker/earthing switch
- TPS single -spring operating mechanism with two independent operating shafts for the load-breaker and earthing switch
- Load-breaker and earthing switch position indicators
- Voltage indicator indicating live bushing
- SF₆ Gas pressure gauge (only one per SF₆ gas compartment)
- Expansion of reserved external busbar
- Motored operation of load-breaker
- Three-phase integrated voltage transformer
- Pluggable surge arrester
- Fuses for PT protection
- Low-voltage compartment at the top of switchgear

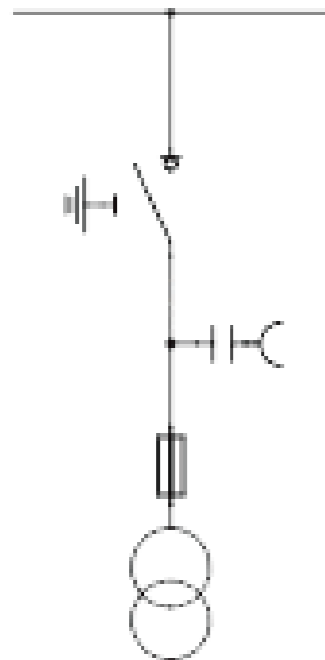

4.7 Cubicle Description - M Metering unit

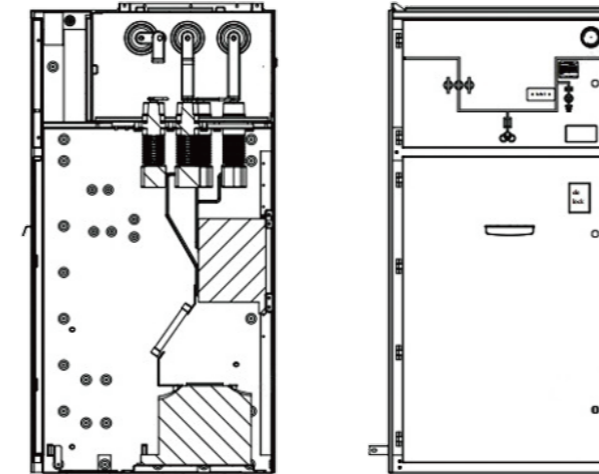

Rated voltage (kv)		12	24
Rated insulation level			
Power frequency withstand voltage 50 Hz - 1 min (rms kV)		28	50
Lightning impulse withstand voltage 1.2/50 μ s (kV peak)		75	125
Rated current (A)	630	■	■
Dimensions (mm)			
Width (W)	750		900
Depth (D)	792		
Height (H)	Instrument box is not included	1502	
	Instrument box	300/350/400	

Function

- 630A internal busbar
- 2 current transformers
- 2 voltage transformers
- Fuses for PT protection
- Voltage indicator indicating live bushing
- 3 current transformers
- 3 voltage transformers
- Watt-hour meter
- Low-voltage compartment at the top of switchgear

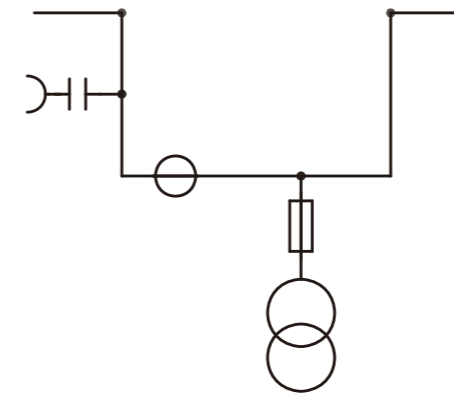

5.1 Panel Design (V-Cabinet Example)

Basic Structure

The switchgear is divided into 4 compartments:

- A. Low-voltage compartment
- B. Power distribution room
- C. Mechanism compartment
- D. Cable connection compartment

1. Low-voltage compartment
2. Operating plate
3. Cable connection compartment door
4. Busbar system
5. Vacuum circuit breaker
6. TPS
7. Circuit breaker operating mechanism
8. TPS operating mechanism

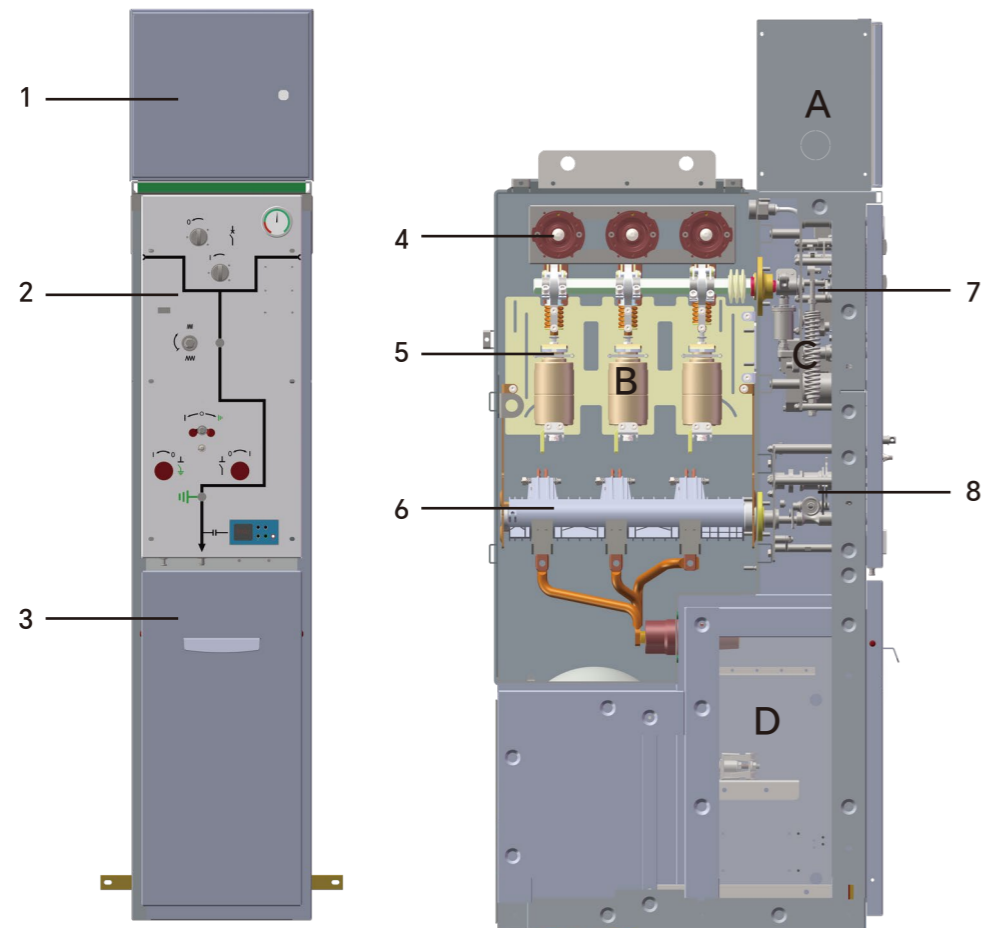

5.2 Panel Design (C-Cabinet Example)

Basic Structure

The switchgear is divided into 4 compartments:

- A. Low-voltage compartment
- B. Power distribution room
- C. Mechanism compartment
- D. Cable connection compartment

1. Low-voltage compartment
2. Operating plate
3. Cable connection compartment door
4. Busbar system
5. Load-breaker
6. Load-breaker operating mechanism

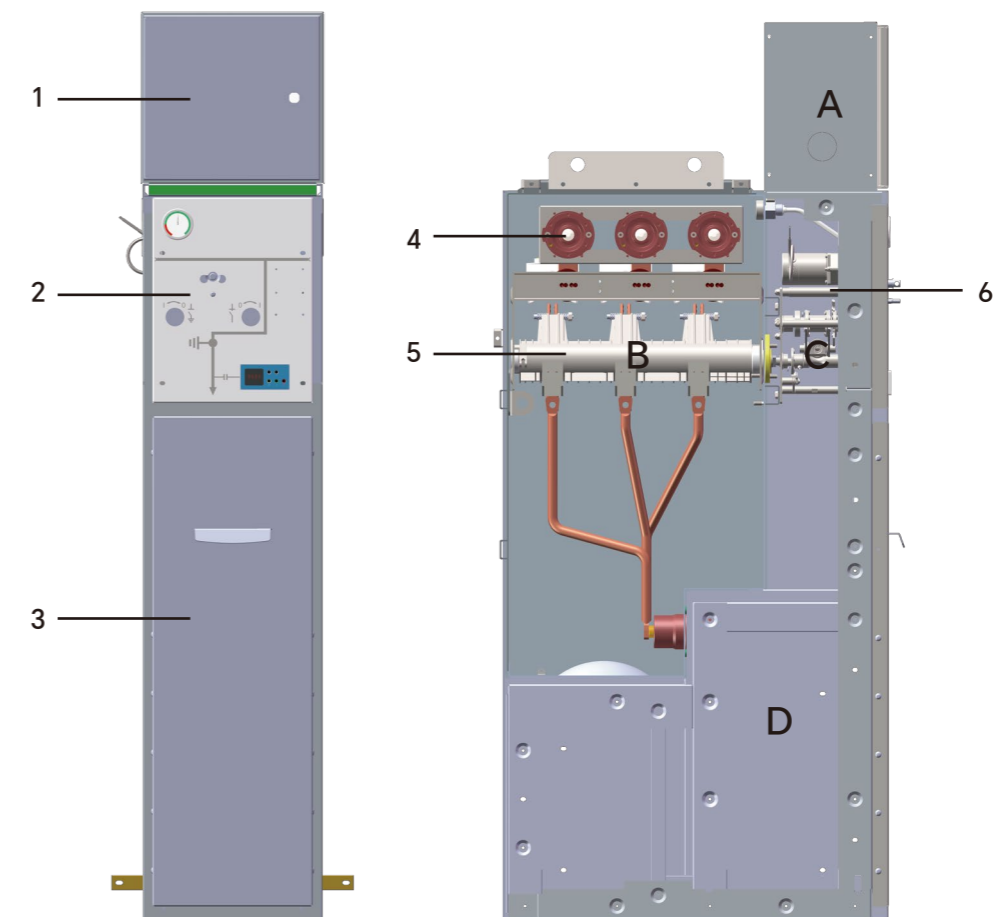

5.3 Panel Design (F-Cabinet Example)

Basic Structure

The switchgear is divided into 4 compartments:

- A. Low-voltage compartment
- B. Power distribution room
- C. Mechanism compartment
- D. Cable connection compartment

1. Low-voltage compartment
2. Operating plate
3. Cable connection compartment door
4. Busbar system
5. Load-breaker
6. Fuse tube
7. Load-breaker operating mechanism

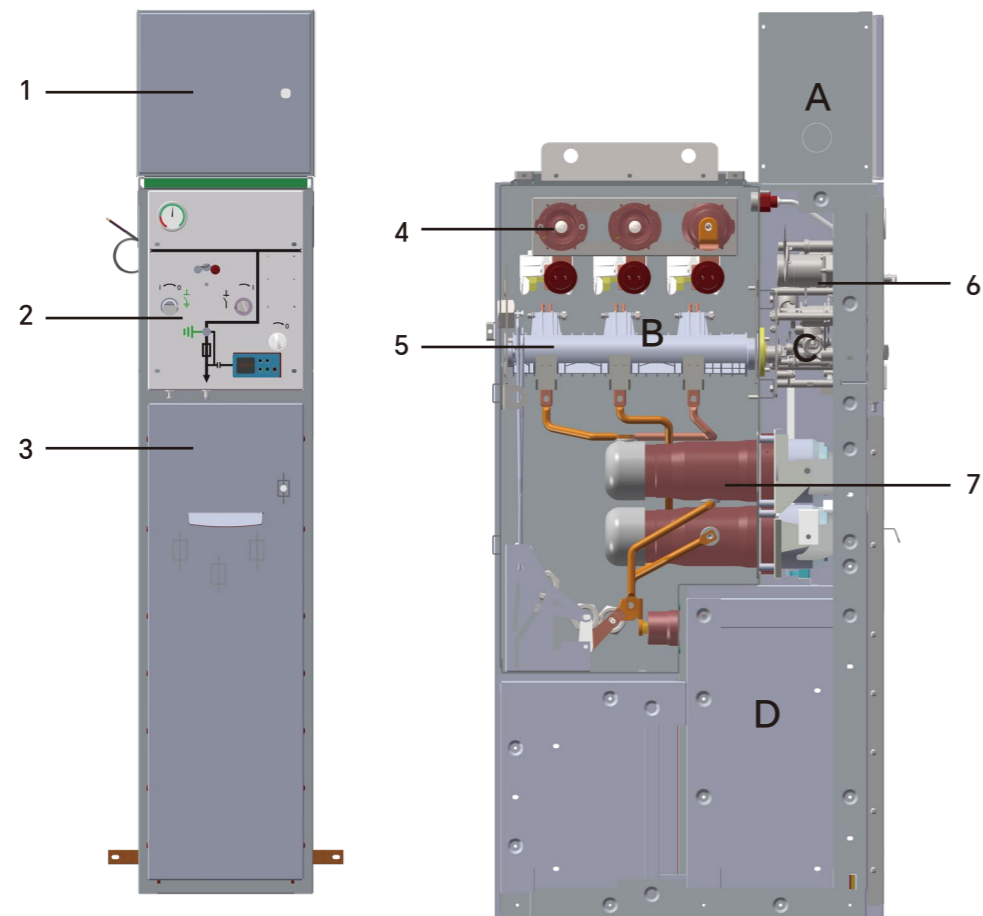

5.4 User Configurable Combination Cabinet Solutions (Non-Expandable Dimensions and Weight for TGS)

Solution	Number of feeders	Height (mm)	Depth (mm)	Width (mm)	Approximate weight (kg)
CC	2	1502	800	708	200
CF					200
CV					240
FF					210
VV					240
CCC	3	1502	800	1048	320
CCF					330
CCV					360
CFF					320
CVV					360
FFF	320				
VVV	350				
CCCC	4	1502	800	1388	440
CCCF					450
CCCV					480
CCFF					470
CCVV					530

5.5 User Configurable Combination Cabinet Solutions (Expandable Dimensions and Weight for TGS)

Solution	Number of feeders	Height (mm)	Depth (mm)	Width (mm)	Approximate weight (kg)
C	1	1502	800	368	135
F					125
V					135
D				500	200
De					200
I				500	250
S				500	200
M				750 / 900	250/300
CC	2	1502	800	708	210
CF					210
CV				708	240
FF					310
VV				868	370
DeF					220
DeV				250	
CCC				3	1502
CCF	340				
CCV	370				
CDeF	1208	330			
CDeV		360			
DDeF		330			
DDeV	360				
CCCC	4	1502	800		
CCCF				460	
CCCV				490	
CCFF				480	
CCVV				540	

5.6 Panel Design (Example) - Compartment

Low-voltage compartment

This compartment includes all low-voltage equipment, such as fuses, miniature circuit breakers, control terminals, protective relays, indicator lights/instruments, push buttons, relays, and control switches, which are installed on the low-voltage compartment door and inside the low-voltage compartment



Low-Voltage Compartment (Example)

Cable connection compartment

The cable connection compartment includes cable interfaces, cable clips, heating and lighting equipment, earthing busbars, etc. Users can configure relevant current transformers, voltage transformers, surge arresters, and other devices according to usage requirements

Cable connection compartment door interlocking is divided into mechanical interlock and electrical interlock. During power outage for maintenance, it can only be unlocked for maintenance when the equipment is de-energized



Cable Connection

5.7 Panel Design (Example)

Busbar Installation in Combination Cabinets

- Clean inner conical bushing
- Clean connectors
- Evenly apply specialized silicone grease on silicone rubber coupling areas
- Install busbars according to the arrow scheme
- Install the mobile cabinet according to the arrow direction
- Assemble adjacent cabinets together and tighten them with bolts

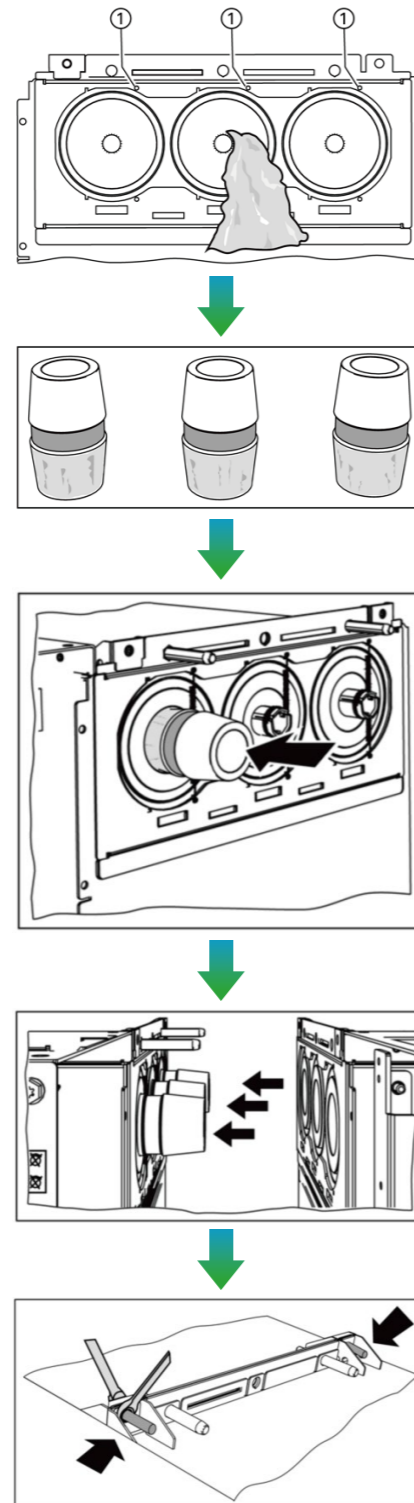

5.8 Description of Control Panel Function

- The control panel integrates operation, mimic diagram, and position indicators, which are related to functions. Work readiness indicators and nameplates are also mounted on the corresponding combination cabinet panels
- On the load-breaker fuse combination electrical device, the two earthing switches upstream and downstream of the medium voltage fuse seat are simultaneously driven by the same mechanism. Load-breaker and vacuum circuit breakers can be selected as optional configurations, equipped with electric control mechanisms
- All operating holes are functionally interlocked, and locks can be optionally applied. Using different operating handles for isolation and earthing operations is also one of the optional designs

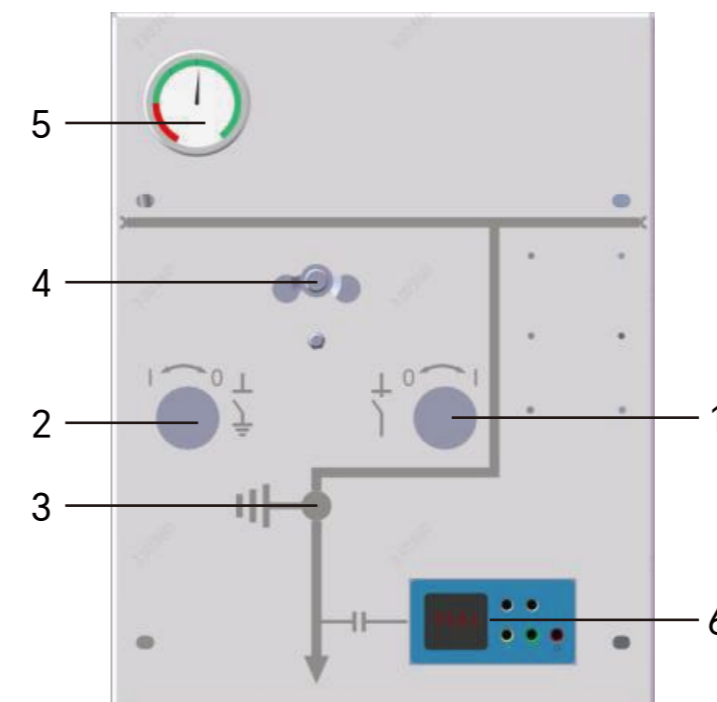

5.9 Composition

1. Load-breaker operating rod socket
2. Earthing switch operating rod socket
3. Load-breaker/earthing switch position indicator
4. Three-position switch locking device
5. Gas pressure gauge
6. Voltage indication system
7. Opening switch for load-breaker (manual trip)
8. Fuse trip indicator
9. Turn Button for opening of circuit breaker
10. Turn Button for closing of circuit breaker
11. Spring energy storage indicator
12. Circuit breaker spring energy charging hole
13. Circuit breaker position indicator
14. Disconnecter operating rod socket
15. Disconnecter/earthing switch position indicator

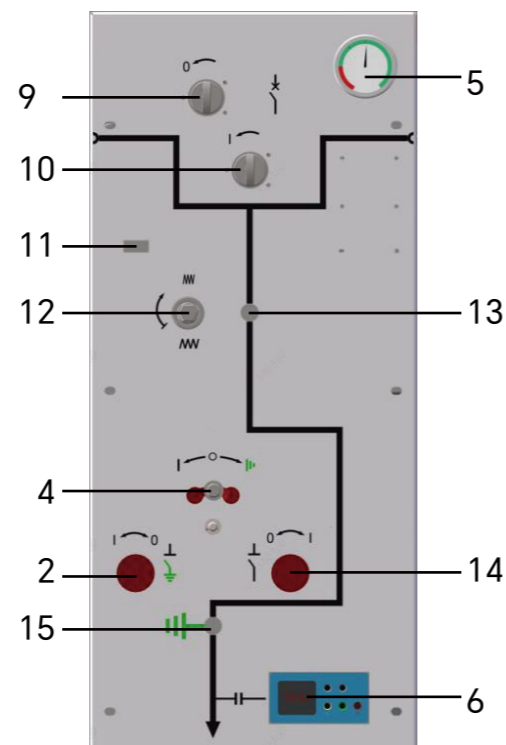
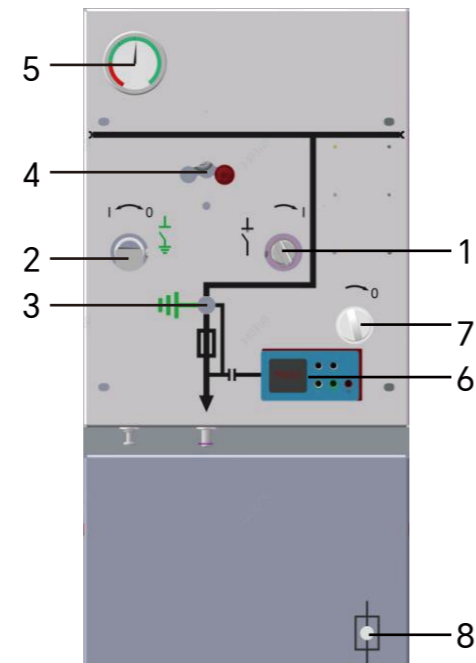

5.10 Current Transformer

Features

- Ring core current transformer design, single-phase use
- Free of dielectric stress epoxy-resin parts
- Insulation class E
- Induction Type
- Connected at the secondary side via internal terminal blocks
- Installed outside of the gas compartment, at the cable connection point of the switchgear; field-installed on the cable

Note: Installation inside the switchgear or below the switchgear depends on the switchgear type and the height of the transformer.

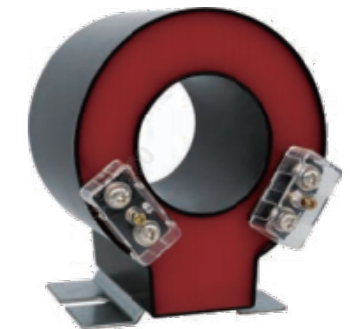

5.11 Bushing Current Transformer

Features

- Ring core current transformer design, three-phase integrated
- Free of dielectric stress epoxy-resin parts
- Induction Type
- Climate-independent
- Secondary side connection via terminal blocks inside the switchgear

Installation

- Installation location:
 - Unit Cabinets C and V (Optional)
 - Installed on the cable connection bushing outside the gas compartment of the switchgear
 - Factory assembly



5.12 Busbar current transformer

Installation

Installation location:

- Installed on shielded busbar outside the gas compartment of the switchgear, as optional busbar current transformer for busbar connection cabinets S and I
- Installed outside the gas compartment of the metering cabinet, with the transformer fixed to the mounting plate at the factory



5.13 Voltage transformer

A voltage transformer is a device used to transform the voltage on a line or busbar, primarily to reduce high voltage to a low voltage suitable for measurement and protection. It is widely used in power systems to measure line voltage, power, and electrical energy, protect valuable equipment, motors, and transformers in the line, and provide electrical isolation with the medium-voltage (MV) section. Its design complies with IEC 61869-3. Its live parts are fully encapsulated with epoxy resin, providing reliable electrical insulation performance and excellent mechanical strength.



5.14 Voltage Indicator

- By interlocking with the capacitive voltage divider insulators of the primary circuit, it displays the live status of each phase voltage in the main circuit in the form of lights
- The voltage indicator is mounted on the door panel of the mechanism compartment, and its voltage coverage complies with IEC 61958, with five levels in total:

- 1.0 ~ 1.9 kV
- 2.0 ~ 3.0 kV
- 3.1 ~ 5.9 kV
- 6.0 ~ 8.9 kV
- 9.0 ~ 17.9 kV



5 Design and Structure

5.15 High-voltage HRC fuse assembly

Features

- Used in electrical devices featuring load-breaker-fuse combination
- High-voltage HRC fuses with medium-sized pins in accordance with IEC 60282-1 (main dimensions) – as short-circuit protection for transformers
 - Selected according to the upstream and downstream connected equipment
 - Single-phase insulation
- Compliant with the requirements of IEC 62271-105 for high-voltage load-breaker-fuse combinations
- Climate-independent and maintenance-free
- Fuse tubes inside the switchgear
- Circuit earthing before fuse replacement
- Reference dimensions for the fuse holder: 292 mm and 442 mm

Optional configurations for TPS load-breaker

- Shunt release
- Remote indication of the load-breaker “tripped signal” via normally opened contacts

Fuse rated voltage (kV)	Transformer capacity (kVA)	Rated current of fuse (A)
12	100 and below	10
	125	16
	160	16
	200	25
	250	25
	315	31.5
	400	40
	500	50
	630	63
	800	80
24	1000	80
	1250	100
	40 and below	6
	100	10
	125	10
	160	10
	200	16
	250	16
	315	20
	400	25
500	31.5	
630	40	
800	50	
1000	63	
1250	80	

6 Transport and Installation

6.1 Packaging

The switchgear is packaged according to the specific requirements of the customer. For international transport, the switchgear must be:

- Placed on a wooden pallet and fixed with bolts
- Sealed with polyethylene film
- Sealed with aluminum foil welding
- Placed desiccant bags for transport in the panel
- Included humidity indicator
- Sealed with fumigated wooden box boards
- Stored for a maximum period of: 6 months

Desiccants are provided inside the switchgear for more effective moisture prevention. Busbars are not pre-installed, and their materials, fasteners, and accessories must be packaged separately.

The use of desiccant bags complies DIN 55473, as detailed below:

- Blue indicator: Container is dry
- Pink indicator: Container is damp (relative humidity exceeds 40%)

6.2 Transport

The final destination will determine the mode of transport, and customer requirements must be followed. When shipped internationally, the switchgear panel must be packaged appropriately according to current conditions (e.g., packaging suitable for sea transport).



Marks Required for Transport

A detailed packing list with the bill of lading will be provided to the carrier during transport to ensure smooth customs clearance at the destination port.

Transportation must comply with the following guidelines:

- Ensure the switchgear should be always upright during the transport
- Provide four ring-type lifting lugs provided for lifting with straps or steel cables
- Ensure the switchgear should be transported inside a sealed container
- Do not stack panels on top of each other
- Always keep the container dry
- Use only lifting equipment that meets the rated capacity of the switchgear panel

Consideration must be given to its high center of gravity characteristics. Loading and unloading operations can only be performed when all personnel protection and material preventive measures have been implemented, and cranes, forklifts, and/or manual hydraulic hand trucks are used.

Crane loading/unloading requirements:

- Lifting ropes and shackles that conform to the load capacity must be provided (opening width ≥ 30 mm, fastening hole diameter 30 mm)
- Lifting ropes and crane hook connection lines must maintain an angle of at least 60° with the horizontal plane;
- Lifting rope must be ensured in good condition
- Crane operators must have appropriate qualifications
- The crane must be located on stable ground and accurately positioned

6.3 Delivery

1. Upon arrival, the switchgear, circuit breakers, and components must be immediately checked for signs of transport damage.

- Any visible external damage must be confirmed by the driver on the freight documentation
- Efforts must be made to check for moisture and its harmful effects
- Based on insurance claim conditions, any damage must be reported in writing to the delivery transport agent within two weeks
- Hidden damage can only be detected after removing the packaging material. Claims for transport damage discovered subsequently will only be accepted by the manufacturer if reported within one week of delivery

2. All components and accessories must be cross-checked against the packing list, with key items including:

- Components
- Tools
- Spare Parts

3. The manufacturer's serial number on the delivery note must match the serial number on the switchgear nameplate exactly.

4. The external unloading of the panels must be carried out in accordance with the operational labels on the fumigated wooden boxes.

6.4 Unpacking

The switchgear must always be kept upright. Switchgear unloading must be performed using a crane with sufficient lifting capacity, and care must be taken during lifting operations to avoid excessive swaying of the equipment.

The following unpacking procedures are for reference only, and actual operations primarily depend on the available resources in the work area:

- First, remove the top cover of the container
- Open the protective panels around the container
- Remove the M12 bolts fixing the switchgear to the transport container chassis (the switchgear is connected to the chassis by M12 bolts)

Notes: All removed M12 bolts will be reused after the switchgear is positioned on the designated foundation.

- The switchgear is equipped with four lifting rings for use with lifting straps or steel cables
- Lift the switchgear vertically off the pallet
- Then, remove the pallet from the bottom of the switchgear and place it in a safe position
- Use a crane to slowly move the switchgear to the installation position or a temporary storage location

Notes: Avoid subjecting the panel to severe impacts and/or vibrations during handling. Do not walk on the top of the panel



View of Switchgear Lifting

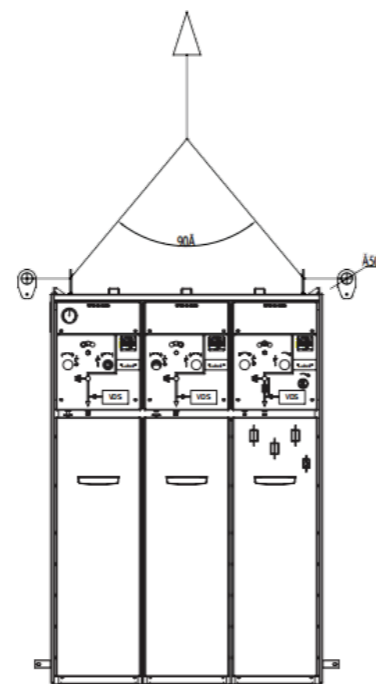

View of Switchgear Lifting

6.5 Precautions

- The switchgear must be kept upright during storage
- Stacking switchgears is strictly prohibited
- The switchgear is not weatherproof, and outdoor storage is prohibited (rainwater and moisture may cause irreversible damage)
- For short-term storage (≤ 2 weeks), the switchgear must be covered with a dustproof plastic sheet
- Do not walk on top of the switchgear

Additional requirements for long-term storage:

- Use heat-sealing moisture-proof cloth to wrap the panel (with the maintenance door must be retained as a visual window)
- Periodically inspect the integrity of the packaging seals

Operational procedures after unpacking the equipment:

- Perform basic maintenance tasks
- Test the minimum operating threshold of the electrical control coils ($\geq 85\%$ of rated voltage)

Installation qualification requirements:

- To ensure the best installation process and quality standards, on-site installation of the switchgear must be performed by qualified personnel who have received professional training, or supervised throughout the operation by a responsible engineer

6.6 Requirements for On-site Conditions

Before installing TGS, the power distribution room must meet the following requirements:

- All civil works must be completed, including the lighting system and structure power supply access
- The room must have a closed function and a dry environment, and be equipped with ventilation facilities
- All cable laying and pre-installation work (wall penetrations, cable trenches, etc.) must be completed before power and control cables are introduced into the switchgear

Installation requirements for special structures:

When an independent pressure relief channel or similar structure is installed at the rear of the switchgear, any one of the following must be met:

- The ceiling height must be sufficient to accommodate the full stroke of the pressure relief baffle
- Configure a pressure relief channel system

Requirements for compliance with mandatory standards:

- All actions should be taken to ensure compliance with the provisions of IEC 62271-200 for indoor switchgear equipment, including environmental conditions for the “-25°C indoor” temperature rating

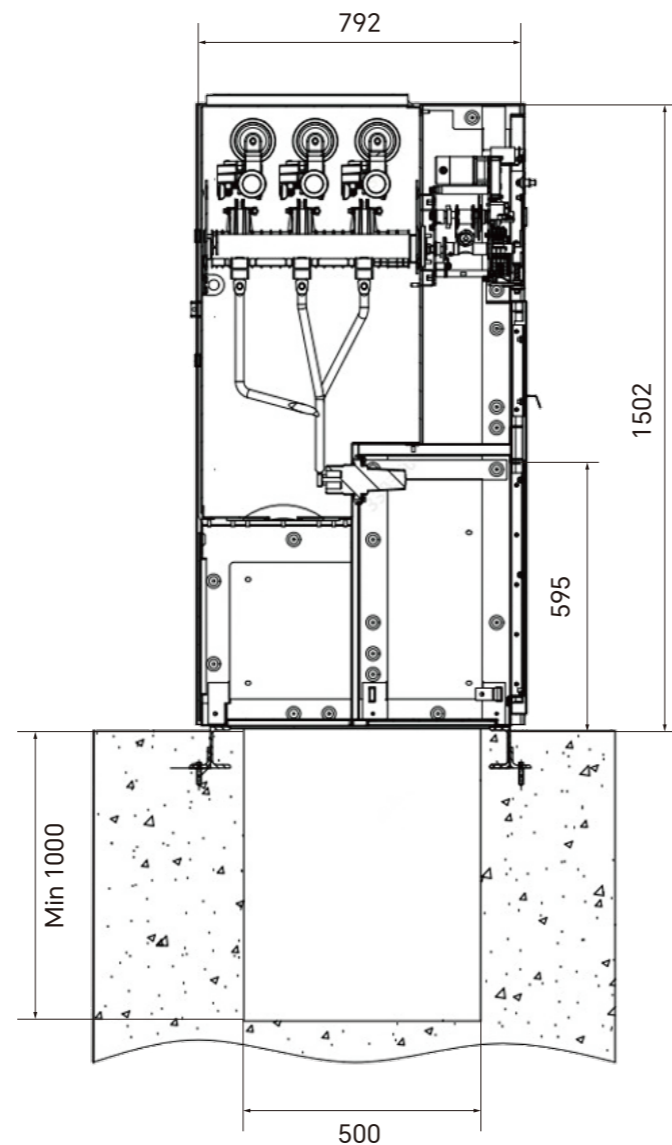

Foundation structure view - including the foundation frame on the concrete base plate

6.7 Base Interface

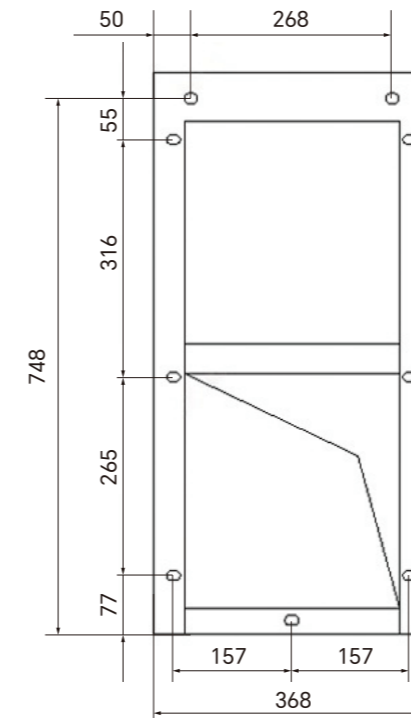

Applicable to Type C load breaker switchgears
 Applicable to Type D cable-connected cabinets
 Applicable to Type V circuit breaker cabinets
 Applicable to Type F transformer cabinets

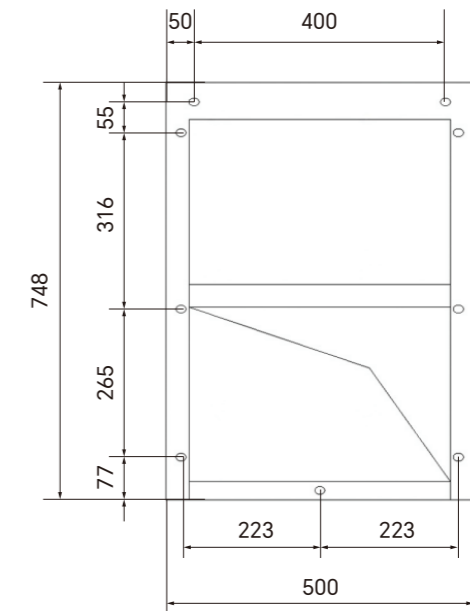

Applicable for Type S busbar connection cabinets with load-breakers
 Applicable for Type I busbar connection cabinets with circuit breakers

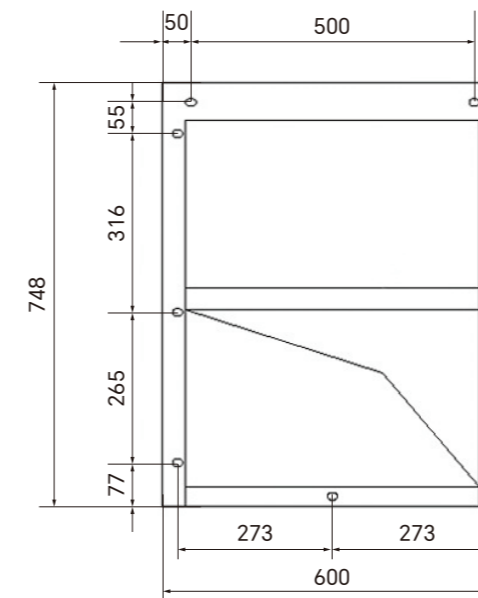

Applicable for Type Cp voltage measuring cabinets with load-breakers

Notes: For cabinets with dual cables and deeper cable connection compartment doors, or other cabinet types, please contact us.