



# THP/TCB

Up to 145kV Hybrid Gas Insulated Switchgear

Catalogue



[www.qdtgood.com](http://www.qdtgood.com)

---

<b>General.....</b>	<b>2</b>
Application .....	2
Benefits.....	3
Quality assurance.....	4
TGOOD services .....	5
<b>Design and Structure .....</b>	<b>6</b>
Components .....	6
<b>Advantage.....</b>	<b>9</b>
Compactness and Flexibility .....	9
Reliability .....	10
Intelligent solutions.....	11
<b>Technical Data .....</b>	<b>12</b>
THP HGIS .....	12
Components .....	13
<b>40.5kV THP .....</b>	<b>14</b>
Dimension and installation .....	14
Inner-bridge configuration.....	16
H type configuration .....	18
<b>72.5kV THP .....</b>	<b>20</b>
Dimension and installation .....	20
Inner-bridge configuration.....	22
H type configuration .....	23
<b>145kV THP .....</b>	<b>24</b>
Dimension and installation .....	24
Configuration.....	28
<b>An Example.....</b>	<b>32</b>
145kV/35kV/6kV power substation.....	32

## Product description

THP is hybrid gas insulated switchgear: Hybrid means integration of advantages of AIS and GIS – usage of mature reliable components of GIS and AIS busbar module.



THP parameters as below:

- Rated voltage: 40.5kV, 72.5kV, 145kV
- Rated current: 2000A~3150A
- Rated short circuit current: 31.5kA~40kA
- Rated short circuit withstand current ( peak): up to 104kA
- Space occupied: average 2.9m<sup>2</sup>

## Application

It has been widely used in many industries:

- Power and renewables
- Railway
- Coal
- Metallurgy
- Petrochemical



THP provides reliable and compact solution for outdoor substations. Its factory-prefabrication and modularization the demand for applications where:

- Substation construction or redevelopment has limited land for the substation
- Lead time for equipment and/or site works is minimal

THP's design and performance is proven by its installation across a wide range of applications and industries worldwide.



## Operational efficiency and reliability

- Reduced substation footprint, capital investment can be reduced significantly
- Reduced civil work saves construction time and cost.
- Pre-assembly and commissioning performed in factory significantly reduces time on site, improves quality, and decreases WHS risks associated with site work.
- Improved reliability through reduced components and critical operating mechanisms insulated from the environment.
- Reduced weight and size resulting in improved transport logistics and cost reduction.
- Significantly lower maintenance than AIS equivalent systems.
- The GIS concept adopted for THP make it suitable to run in the harshest environments with reliability.
- Intelligent solution for THP increase the operation efficiency in terms of monitoring, analysis and control

TGOOD THP is the ideal solution to High Voltage Substations applications that don't have the land available required for traditional Air Insulated Substations, but still want an Outdoor Substation without the costs associated with fully Gas Insulated Substations.



**Quality assurance**  
**Certified quality: ISO 9001**

**A major asset**

TGOOD integrates a functional organization whose main role is to check quality and monitor compliance with standards. This procedure is:

- uniform throughout all departments
- recognized by many customers and approved organizations. But above all, it is its strict application that has allowed us to obtain the recognition of an independent organization:

The International Accreditation Forum (IAF). The quality system for the design and manufacture of THP is certified to be in conformity with the requirements of ISO 9001: 2008 quality assurance standard.

**Strict and systematic checks**

During manufacture, each THP functional unit is subject to systematic routine testing with the aim of checking the quality and conformity of the following features:

- measuring of opening and closing speeds
- dielectric test
- testing of safety systems and interlocks
- testing of low voltage components
- conformity with drawings and diagrams.

The results obtained are recorded and approved by the quality control department on each device's test certificate. This therefore guarantees product traceability. Control of vacuum interrupters Each vacuum interrupter, sealed and airtight, is checked for the quality of the vacuum obtained. This pressure measurement is based on the proven "magnetron discharge" method. Using this sophisticated procedure, measurement is very precise and does not require access to the inside of the bulb, thus not affecting the airtight seal.



**Environment protected**

As part of the group's environmental policy, TGOOD provides you an option to recover high voltage switchgear and thus eliminate any discharge to atmosphere. In order to help you protect the environment and to relieve you of any concerns in terms of stock or dismantling, TGOOD service offers to take back your equipment at the end of its life. THP has been designed with environmental protection in mind:

- all materials used, for instance insulators and conductors, are identified, and easily separable for recyclable.
- SF<sub>6</sub> usage is reduced in THP, and SF<sub>6</sub> can be recovered at the end of the equipment's life and reused after treatment.
- production sites are certified to ISO 14001.



**Occupational health and safety**

Occupational Health and Safety (OH&S) bears highest importance at TGOOD. TGOOD demonstrates its commitment towards control of the risks and improvement in performance of OH&S by complying to OHSAS 18001:2007 certified by China National Accreditation Service (CNAS). TGOOD management believes in process approach and its policy is based on PDCA methodology that focuses on elimination or minimizing risks to personnel and other interested parties who could be exposed to OH&S hazards associated with its activities. Strong mechanisms are in place to assure that TGOOD performance on OH&S not only meets, but will exceed its legal and policy requirements.

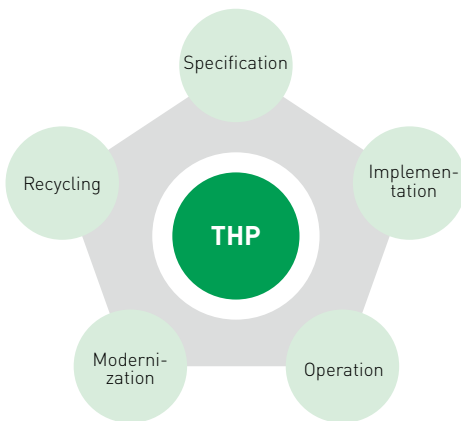

TGOOD provide service near you throughout the life of your installation

### Specifying

Assist help you to define your solutions: selection guide, technical assistance, expert advice...

### Implementing

Provide supervision of/or installation and commissioning of your system, integrate other TGOOD or 3rd party systems, or provide full turnkey EPC solutions where applicable.

### Operating

Manage your daily operations in real time: maintenance contract, technical assistance, supply of replacement parts, corrective and preventive maintenance, operation and maintenance training, etc.

### Modernizing

We can upgrade the performance of your installation keeping up to date with emerging industry best practices and compliance to regulation changes: installation audit, switchgear diagnosis, adaptation and modification, and end of life recycling..

### Recycling

A service to dismantle your complete switchgear at the end of its service life: disassembly, material data sheets, environmentally-compatible recycling.

### Examples of services provided

- Warranty extension  
Extended warranty is available upon application.
- Circuit-breaker-disconnector diagnosis  
Throughout the life of the equipment carry out routine measurement of its characteristics in order to optimize maintenance. This service may be part of a global installation maintenance contract.
- End-of-life recycling  
TGOOD Services have an operational subsidiary supporting you to recycle your high voltage switchgear.

Similar to GIS, hybrid GIS THP integrates versatile modules:

- Circuit breaker
- 3-position disconnect/earthing switch
- Current transformer (CT)
- Voltage transformer (VT)
- Local control cubicle

The busbar is not included because busbar is not assembled in SF<sub>6</sub> gas chamber, so the structure is clear, simple and compact, which shall ensure convenient assembly, repair, maintenance and reliable operation.



- |                                          |                                     |
|------------------------------------------|-------------------------------------|
| 1. Bushing                               | 4. Current transformer (CT)         |
| 2. 3-position disconnect/earthing switch | 5. Operation mechanism              |
| 3. Circuit breaker                       | 6. Local control cubicle            |
|                                          | 7. 3-position-switch viewing window |

**Circuit breaker**

The core component of THP is circuit breaker, which is composed of:

- Automatic arc-extinguishing chamber
- Spring mechanism.

During large current switching, the arc energy heats and inflates the thermal expansion chamber, the one-way valve is closed. At current zero-crossing, the high pressure gas in the thermal expansion chamber blows at the fracture to extinguish the arc. During the opening process, the gas in supporting compression chamber is compressed; the pressure-relief valve will be opened when a threshold value is reached, to avoid over-large reaction force of compression on the mechanism, in this way the operation power can be reduced remarkably.

During small current switching, pressure generated from thermal expansion chamber is low, which is lower than pressure in the supporting compression chamber; at this point the one-way valve is opened, the compressed gas blows at the fracture.

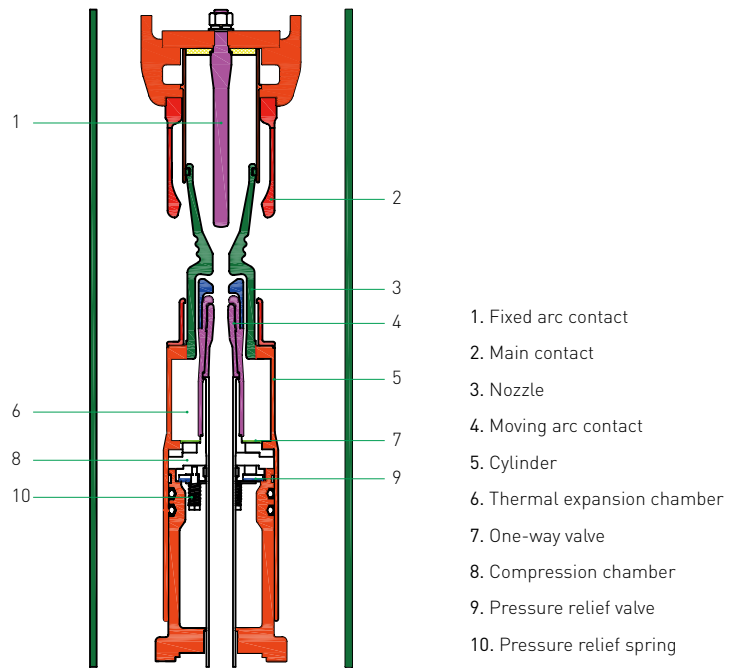

*Structure of arc-extinguishing chamber*

Characteristics:

- Automatic arc-extinguishing chamber reduce the operation power
- Mature CT-30 operation mechanism
- Long mechanical lifespan with reliability

## 3-Position switch

The functions of disconnector and earthing switch are integrated into a 3-position switching device, which share a rotary moving contact. The overall structure is simplified and the dimension is reduced. The 3-position structure shall avoid mis-operation between normal disconnector and earthing switch in terms of mechanical structure, so that the electrical interlock is simplified. The CJ-23 3-position disconnector mechanism enhances reliable switching.

Characteristics:

- 3-position structure reduces electrical interlocks and enhances reliability
- The contact of 3-position switch increases the current flux
- Its operation mechanism with clutch can realize manual operation, 10NO 10NC auxiliary contacts are provided
- 2 peeholes facilitate visual inspection of contact position

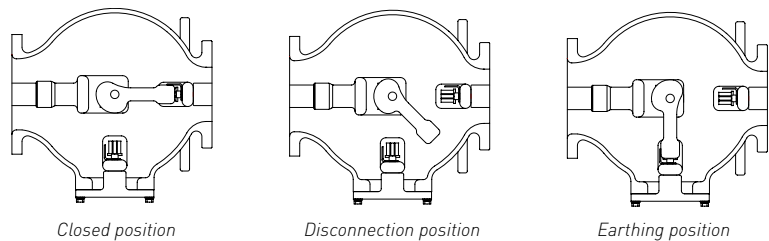

## Bushing

The silicon rubber composite insulation bushing is made from epoxy resin impregnated fiberglass tube with silicone rubber shed.

Traditional porcelain bushing can be provided for special circumstances.

Characteristics:

- Excellent safety performance (fracture / explosion resistance)
- Light weight
- Outstanding pollution / rain resistant performance (water repellent);
- Dust storm resistant;
- Maintenance-free

## Current transformer

Bushing type ring core CT is used for the THP. The external assembly of current transformer shall facilitate maintenance and replacement as well as production. Each CT can be equipped with multiple winding if necessary.

## Local control cubicle (LCC)

LCC adopts double layer enclosure, with better heat insulation / waterproofing performance, shall ensure reliable operation of electronic elements inside.

Characteristics:

- Stainless steel enclosure ensuring long-term reliable outdoor application
- Position indication of all units
- Electrical interlocking
- Signals to central control room and protective equipment
- Sensors equipped for temperature / humidity and heating device
- IP4XDW



Local control panel

This kind of design for THP brings advantages of compactness, flexibility, and reliability, furthermore, a built-in intelligent solution also can be provided on customer request.

## Compactness

Similar to compact structure of GIS, the circuit breaker, disconnector and VT are integrated into a fully-enclosed system of THP which is filled with SF<sub>6</sub>.

- Land saving, one-time investment can be reduced
- Civil work can be reduced
- Weight and size can be reduced; compartment delivered as a whole
- Short power-off time during substation reconstruction



*Double busbar arrangement*



*Single busbar arrangement*

## Flexibility

The different modules of THP can be combined to different solution which meet diversified demands. The main advantage includes:

- Indoor or outdoor application
- Short delivery time
- Double busbar and single busbar arrangement



*Roof installation*



*Indoor installation*

THP decreases some risks which exist on AIS:

- Low reliability of disconnector and Circuit Breaker during outdoor operation
- Porcelain bottle damage
- Operation failure
- Overheat of conduction main circuit
- Corrosion

The reliability of THP is enhanced thanks to reduced quantity of components and pre-assembly & factory commissioning:

- Component quantity reduced

Due to optimized design, the quantity of insulation bushing and support bar is reduced by 30% ~ 50% for THP; the flashover (to earth) frequency of insulation support bar caused by pollution is reduced, the operation reliability is enhanced as a result.

- Pre-assembly & factory commissioning

In contrast with AIS, the characteristic of THP is that the assembly and commissioning of the equipment can be performed in workshop, so that the quality of equipment can be enhanced.

According to statistics<sup>[1]</sup>, 70% defects of the newly-built substation within 2 years are resulted from quality problems of assembly and commissioning, which are eliminated in workshop for THP. One THP means a complete protection compartment. All internal components are assembled in workshops with cleanness level of 100,000 ppm.



*Voltage withstand routine test*



*Circuit resistance measurement*

[1] Resource from SGCC information



*Intelligent substation*

THP can provide on-line monitoring, data analysis and automatic diagnosis through sensor and intelligent terminal technologies.

Characteristics:

- Electronic transformer: which features small size, light weight, high precision, large bandwidth, large measurement scope, good linearity, mature technologies and simple structure
- Optical fiber communication: it replaces complicated control cables to simplify the secondary wiring and reduce cost
- Intelligent terminal: It converts the opening and closing commands from protection, measurement and control device
- Digital monitoring: on-line monitoring and management system discover defects of equipment in time and reduce unexpected issues

### Electronic transformer

It is integral to the functioning of a smart substation, which takes digital measurements of primary circuit in substation. The electronic transformer can be divided into active and passive type according to the criteria that whether power supply is needed at high voltage side.

- The active electronic transformer shall measure the primary large current through Rogowski coil or LPCT coil, and measure primary high voltage through capacitive voltage divider or reactive voltage divider.
- Passive electronic transformer shall measure current through Faraday magneto-optic effect and Sagnac effect, and measure the voltage through Pockel electro-optic effect.



*Electronic CT*



*Electronic VT*

Hybrid GIS THP

Items		Unit	Parameter			
Rated voltage		kV	40.5	72.5	145	
Rated current		A	2000	2500	2500	
Rated frequency		Hz	50, 60	50,60	50, 60	
Rated power frequency withstand voltage (1 min)	between phases, between phase and earth	kV	95	140	275	
	fracture	kV	118	160	315	
Rated lightning impulse withstand voltage (peak)	between phases, between phase and earth	kV	185	325	650	
	fracture	kV	215	375	750	
Rated short time withstand current		kA	31.5	40	40	
Rated peak withstand current		kA	80	104	104	
Rated short-circuit duration		s	3	3	3	
Resistance of main circuit		$\mu\Omega$	$\leq 140$	$\leq 140$	$\leq 140$	
SF <sub>6</sub> gas pressure (gauge pressure, 20°C)	Rated pressure	MPa	0.50	0.62	0.65	
	Alarming pressure	MPa	0.45	0.60	0.62	
	Locking pressure	MPa	0.40	0.60	0.60	
Water content of SF <sub>6</sub> gas (value at 20°C during acceptance inspection)		ppm(v/v)	$\leq 150$	$\leq 150$	$\leq 150$	
Annual leakage ratio of SF <sub>6</sub> gas		%/year	$\leq 0.1$	$\leq 0.1$	$\leq 0.1$	
Level of partial discharge	1 compartment	pC	$\leq 5$	$\leq 5$	$\leq 5$	
	single insulating part	pC	$\leq 3$	$\leq 3$	$\leq 3$	
Noise level		dB(A)	$\leq 80$	$\leq 110$	$\leq 110$	
Bushing	Material	Porcelain or composite material				
	Creepage distance	mm	1013/1256	1813/2248	3625/4495	
	Static load on terminal	Horizontal longitudinal	N	750	750	1250
		Horizontal transverse	N	500	750	750
Vertical		N	750	1000	1000	
Ambient temperature	Lowest <sup>(1)</sup>	°C	-35	-25	-25	
	Highest	°C	40	40	40	
Altitude <sup>(2)</sup>		m	$\leq 2000$	$\leq 2000$	$\leq 2000$	

(1) Ambient temperature: -45°C~+55°C is optional;

(2) Higher altitude can be reached on request.

## TCB Circuit breaker

Items	Unit	Parameter		
Rated voltage	kV	40.5	72.5	145
Rated current	A	3150	3150	3150
First-pole-to-clear factor		1.5	1.5	1.5
Rated short-circuit breaking current	kA	31.5	40	40
Rated short-circuit making current (peak)	kA	80	104	104
Capacitive current swithing	Line-charging	A	50	50
	Cable-charging	A	160	160
Rated operating sequence		0 – 0.3s – CO – 180s – CO		
Accumulative breaking times under rated short circuit breaking current	times	20	20	20
Mechanical lifecycle	times	10,000	10,000	10,000
Opening time (under rated operating voltage)	ms	50±10	30±5	30±5
Closing time (under rated operating voltage)	ms	70±10	80±10	80±10
Inter-phase unsynchronized opening time	ms	≤3	≤3	≤3
Inter-phase unsynchronized closing time	ms	≤5	≤5	≤5

## Mechanism of disconnecter / earthing switch

Items	Unit	Parameter
Mechanical lifecycle	times	2000 / 2000
Opening time	s	3~4
Closing time	s	3~4
Operating mechanism	Rated voltage	V AC/DC 220
	Rated output power	W 360
	Output torque	N•m 120

## Current transformer

Items	Unit	Parameter	Remark
Normal transformer	Current at primary side	A 150/200/300/400/600/800/1000/1200/1600 /2000/3000	Detailed CT parameters shall be determined through negotiation between buyer and seller.
	Current at secondary side	5/1	
	Capacity	VA 15/20/30/40	
	Accuracy class	Measurement: 0.2s/0.2/0.5; Protection: 5P/10P	
Electronic transformer	Current at primary side	A 150/200/300/400/600/800/1000/1200/1600 /2000/3150	
	Rated secondary output	01CFH (protection), 2D41H(measurement)	
	Accuracy class	5TPE (protection), 0.2s (measurement)	

Out size dimensions

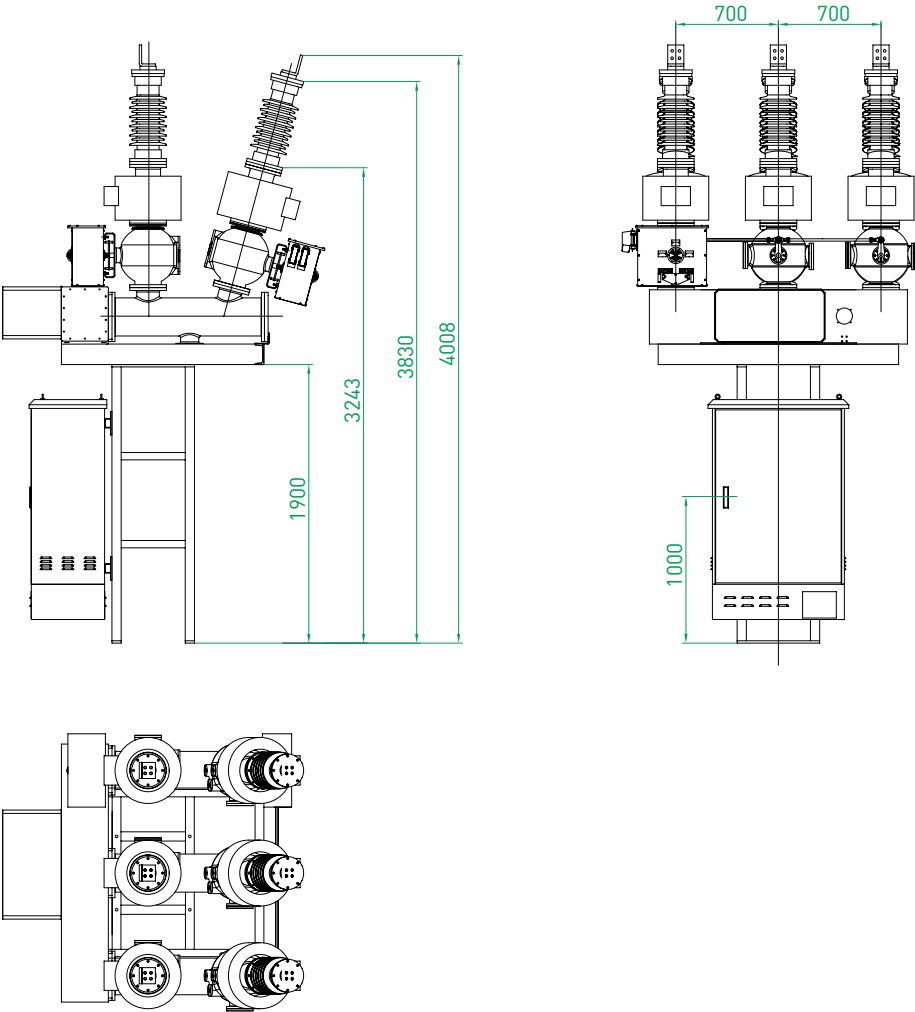

Foundation drawing

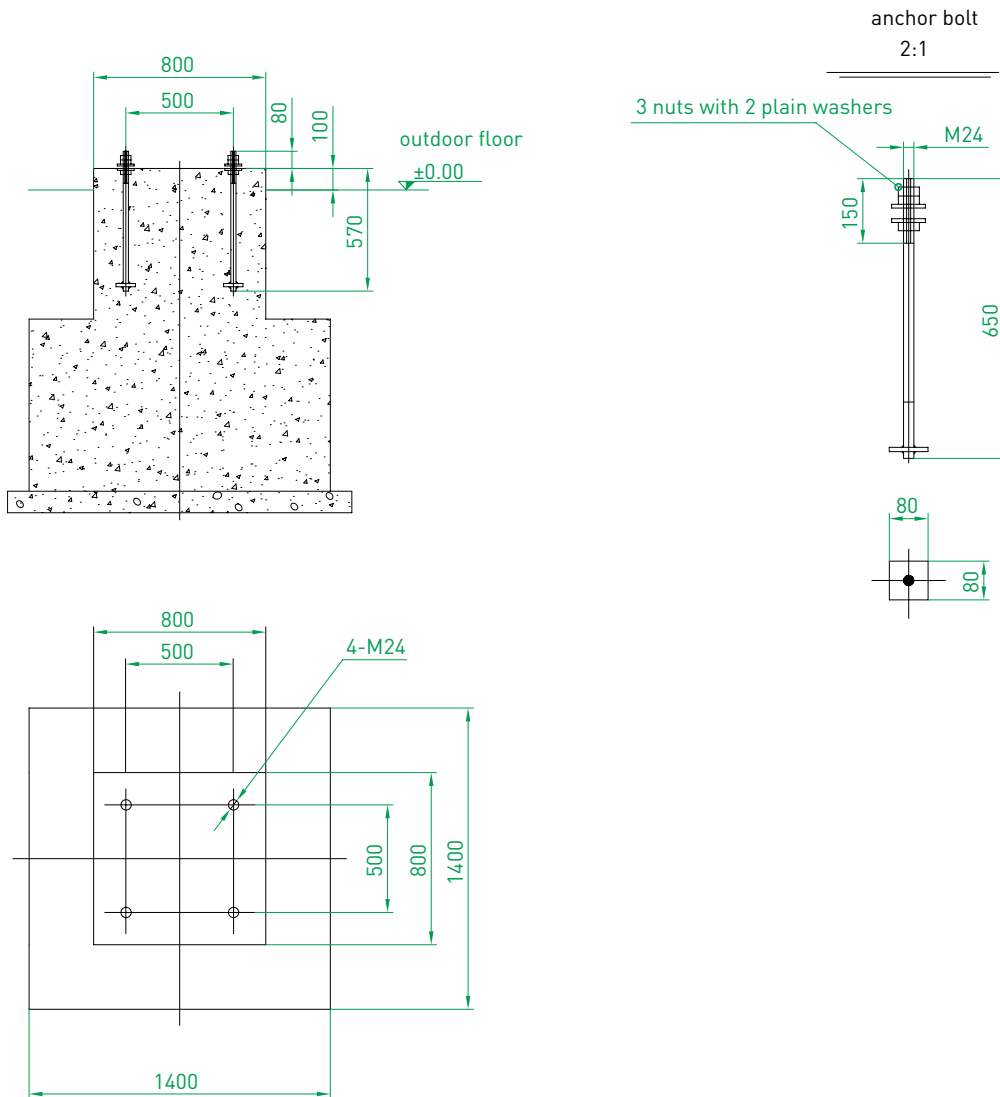

Note:

1. The anchor bolts shall be made of Q235-A steel. Chamfer the ends of thread area [2 x 45°]; surface roughness of thread area is Ra6.3, the value for the rest area is Ra25. The fillet weld height of bottom square board > 8mm; all parts shall be treated with thermal galvanization, the zinc-layer thickness shall be greater than 85µm. The dimension requirements are for product after galvanization.
2. The length of the exposed part of the embedded M24 anchor bolt shall be 80mm; dimension tolerance of anchor bolt is +1mm.
3. Dimension template can be used during the assembly of M24 anchor bolt to ensure the dimension tolerance.
4. The foundation drawing is only for reference. The construction drawing must be designed according to local geological conditions.

## Electrical diagram

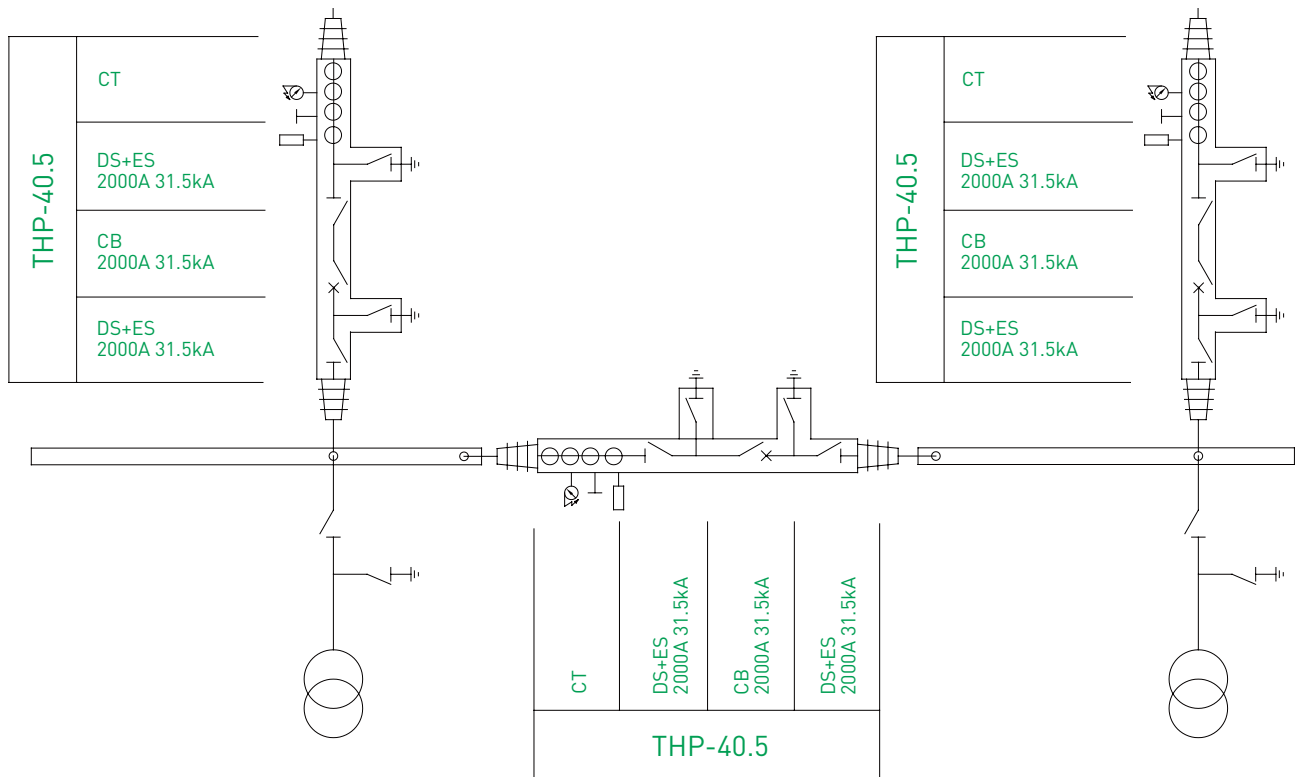

Layout

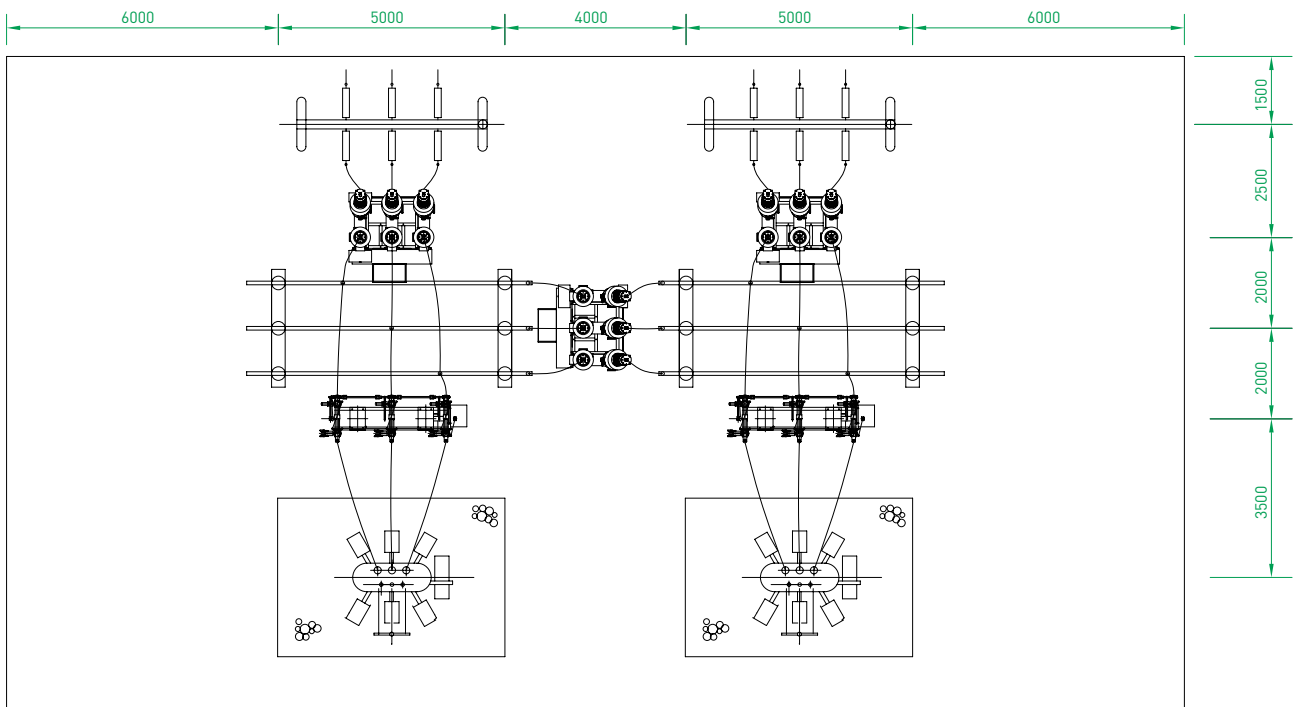

Section drawing

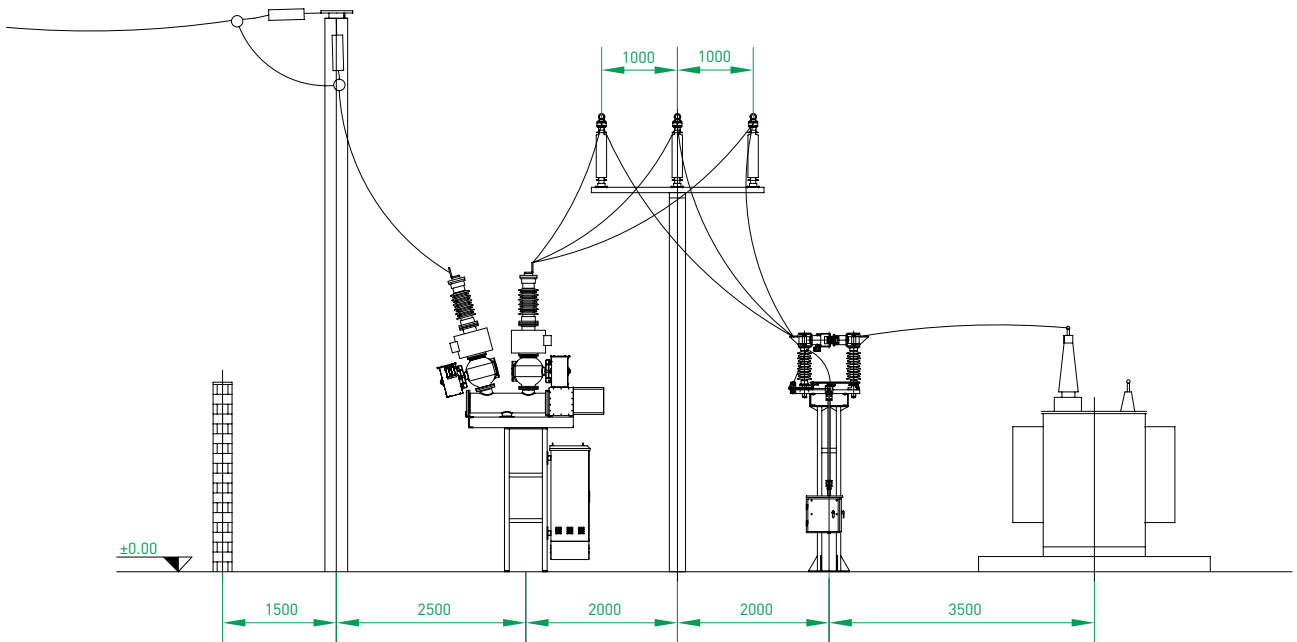

## Electrical diagram

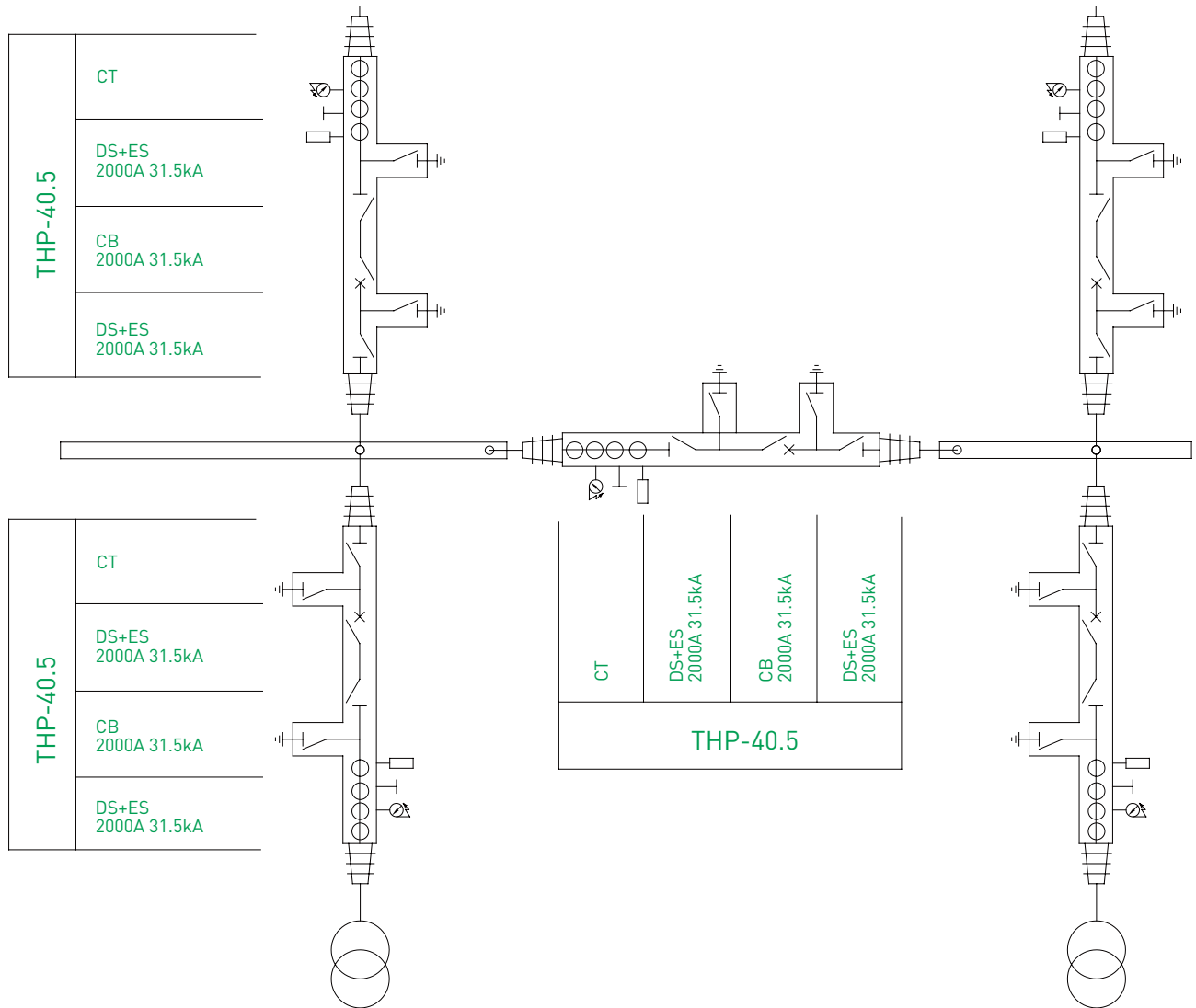

Layout

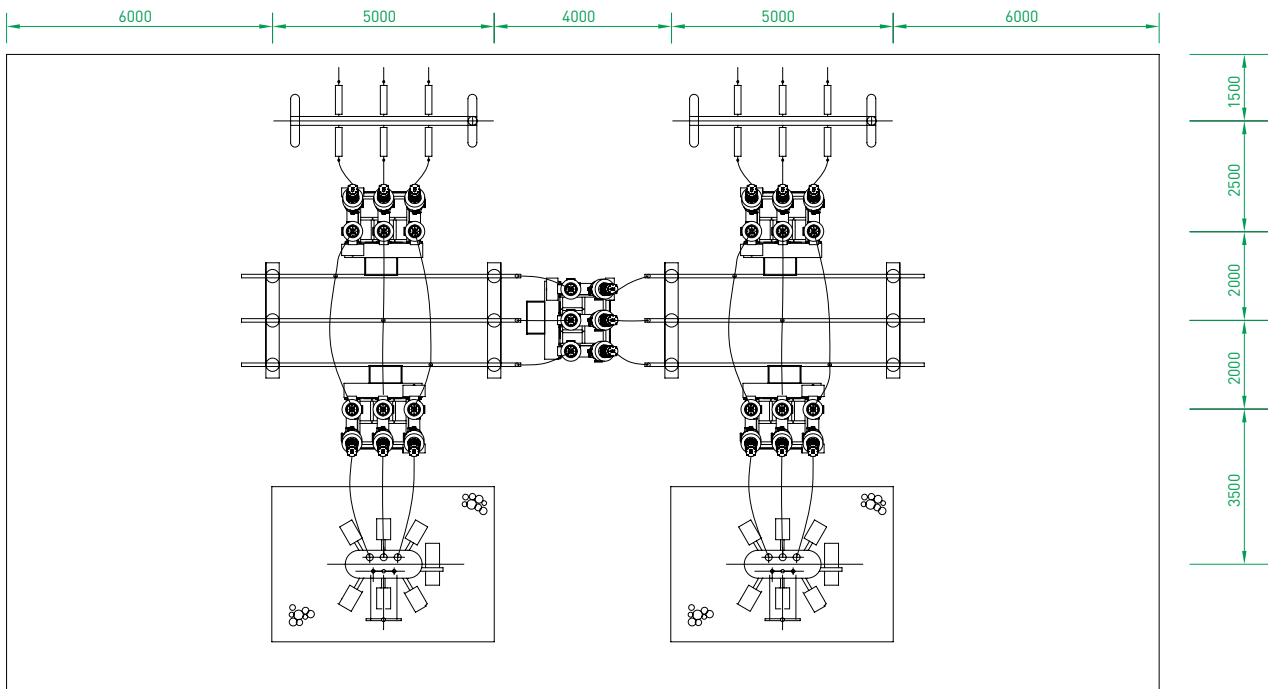

Section drawing

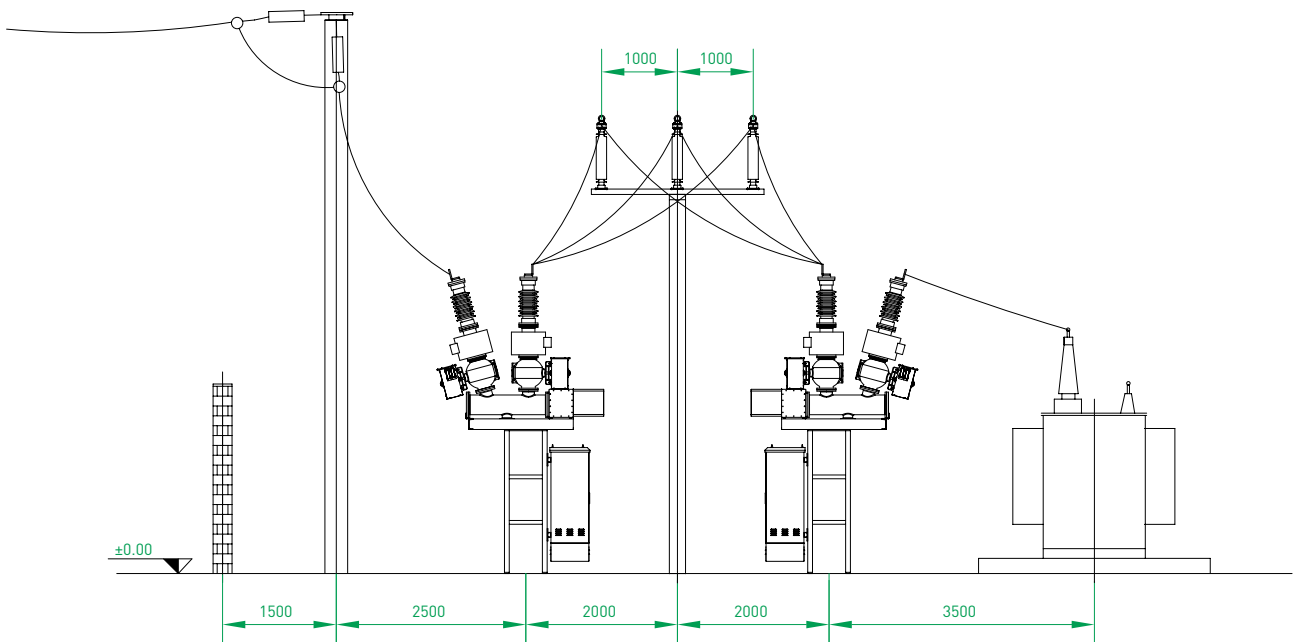

Out size with single busbar

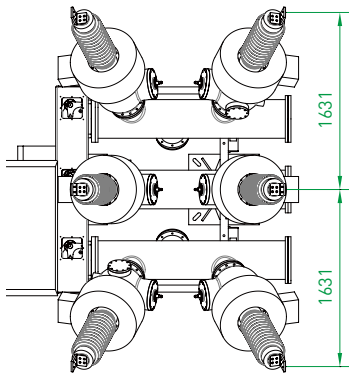
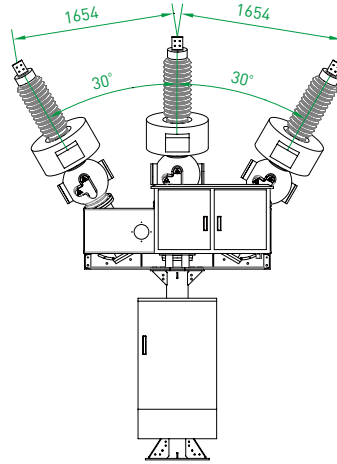
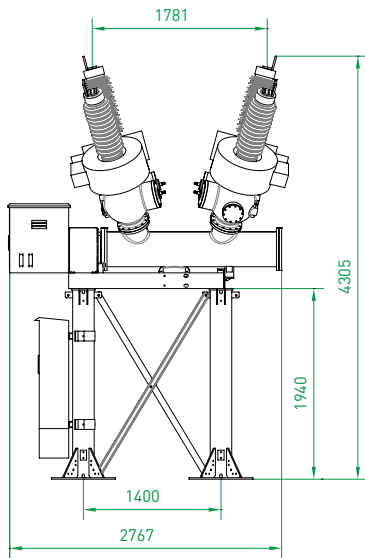

Foundation with single busbar

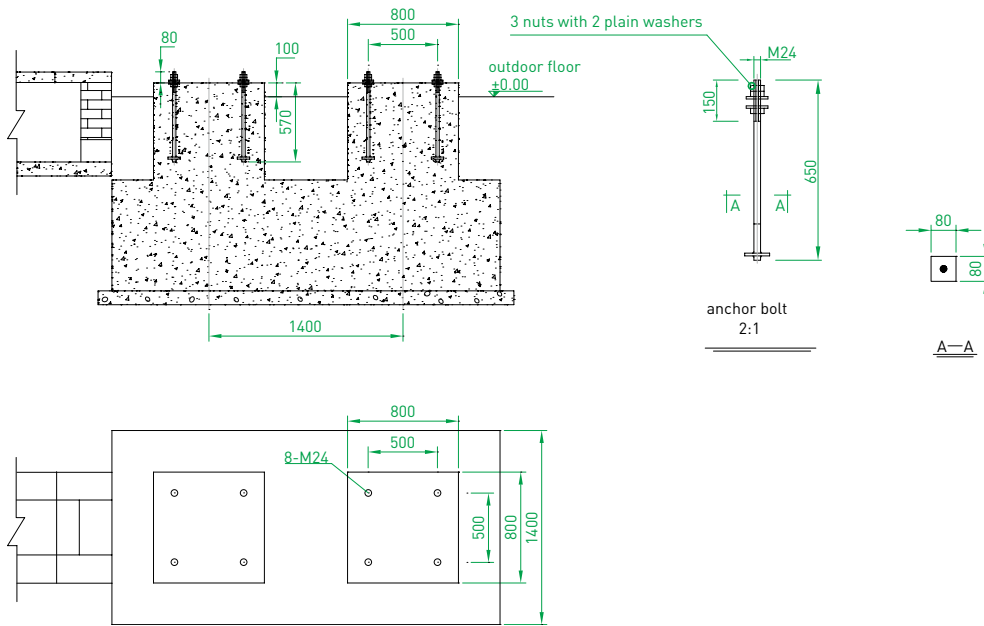

Note:

1. The anchor bolts shall be made of Q235-A steel. Chamfer the ends of thread area [2 x 45°]; surface roughness of thread area is Ra6.3, the value for the rest area is Ra25. The fillet weld height of bottom square board > 8mm; all parts shall be treated with thermal galvanization, the zinc-layer thickness shall be greater than 85 $\mu$ m. The dimension requirements are for product after galvanization.
2. The length of the exposed part of the embedded M24 anchor bolt shall be 80mm; dimension tolerance of anchor bolt is +1mm.
3. Dimension template can be used during the assembly of M24 anchor bolt to ensure the dimension tolerance.
4. The foundation drawing is only for reference. The construction drawing must be designed according to local geological conditions.

## Electrical diagram

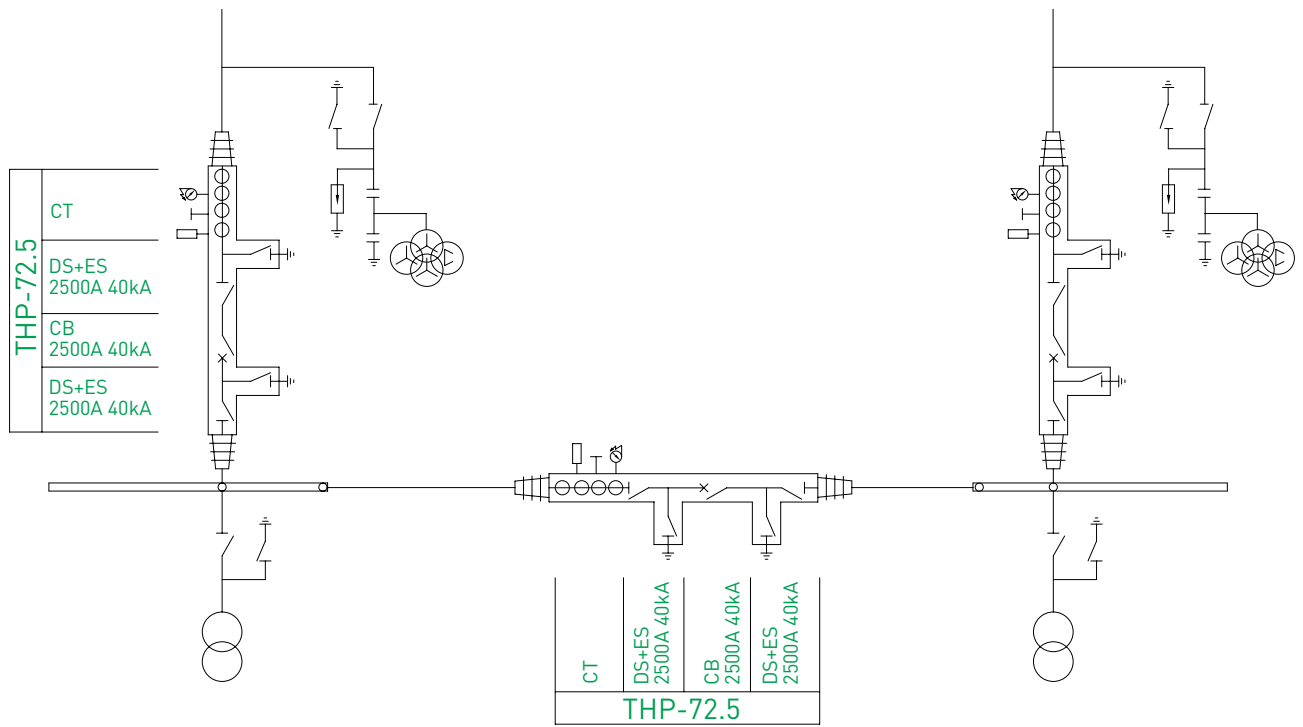

## Electrical diagram

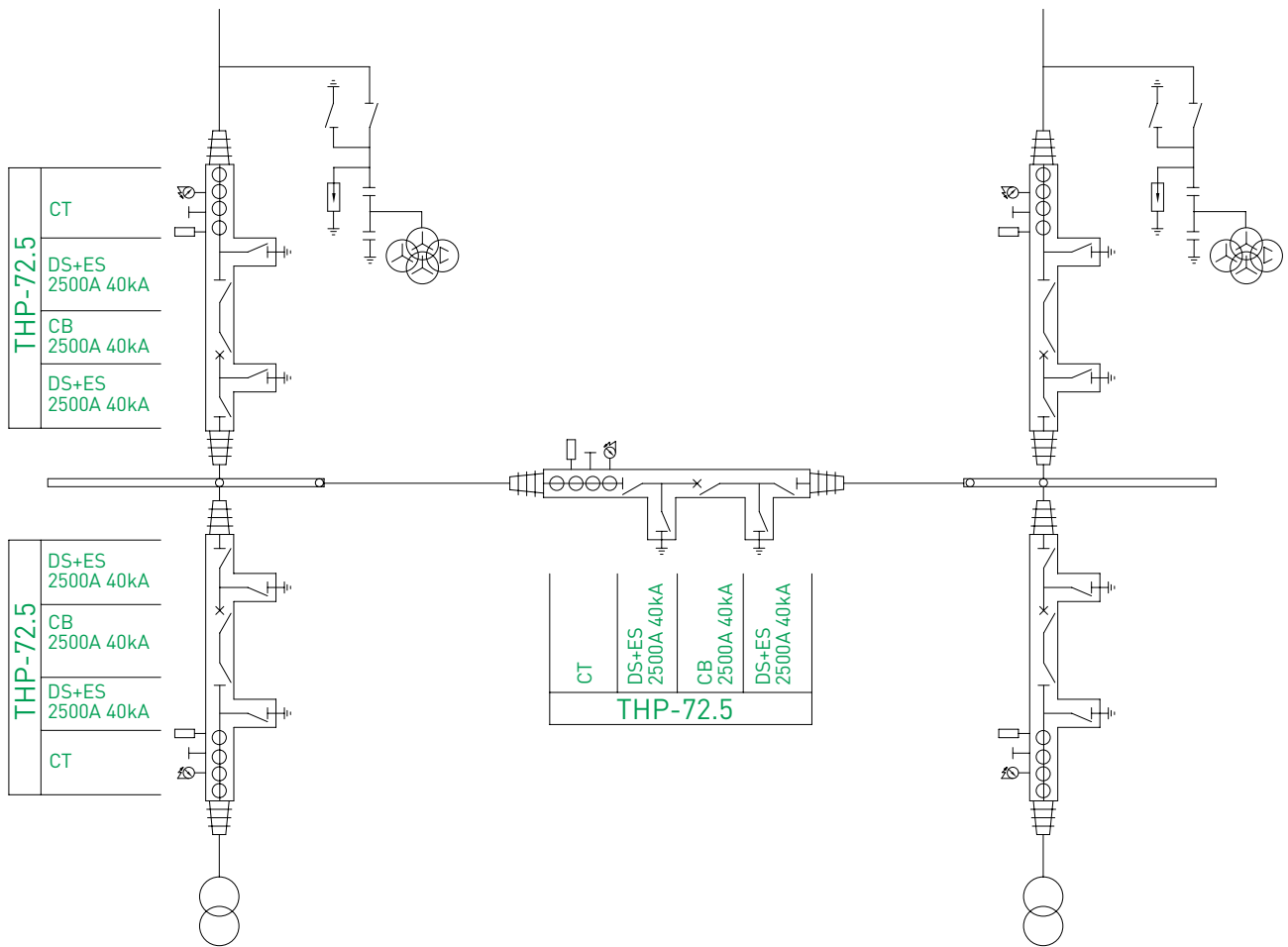

Out size with single busbar

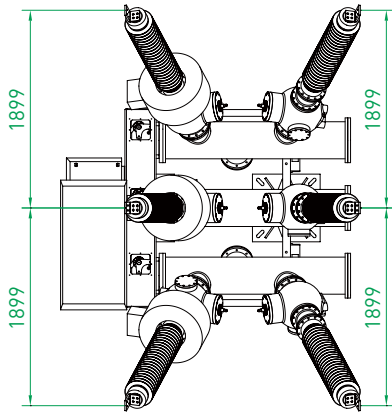
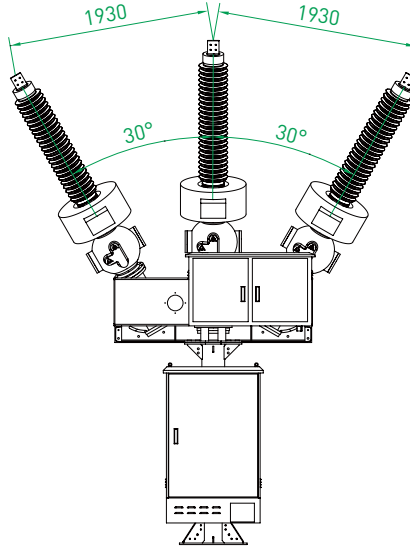
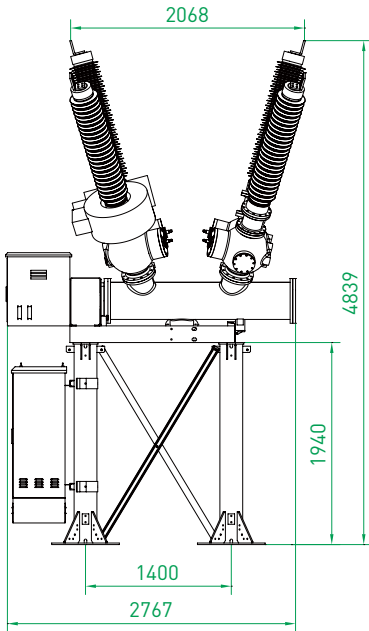

Foundation with single busbar

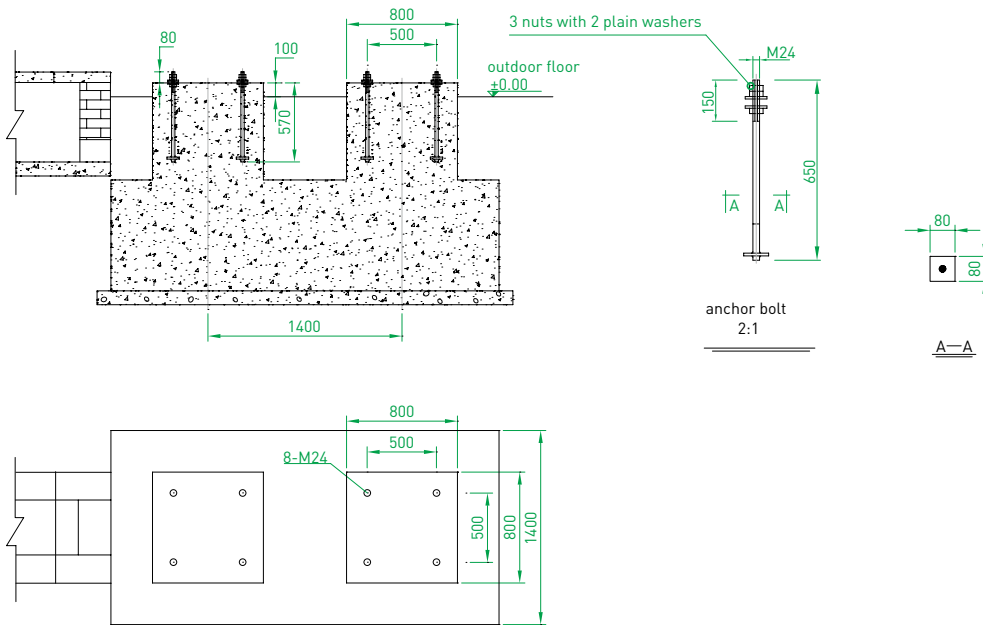

Note:

1. The anchor bolts shall be made of Q235-A steel. Chamfer the ends of thread area [2 x 45°]; surface roughness of thread area is Ra6.3, the value for the rest area is Ra25. The fillet weld height of bottom square board > 8mm; all parts shall be treated with thermal galvanization, the zinc-layer thickness shall be greater than 85µm. The dimension requirements are for product after galvanization.
2. The length of the exposed part of the embedded M24 anchor bolt shall be 80mm; dimension tolerance of anchor bolt is +1mm.
3. Dimension template can be used during the assembly of M24 anchor bolt to ensure the dimension tolerance.
4. The foundation drawing is only for reference. The construction drawing must be designed according to local geological conditions.

Out size with double busbar

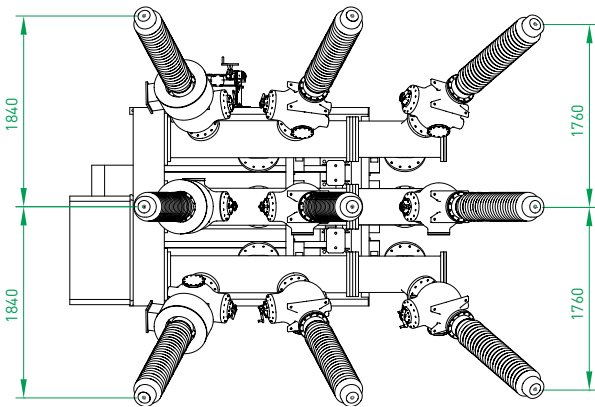
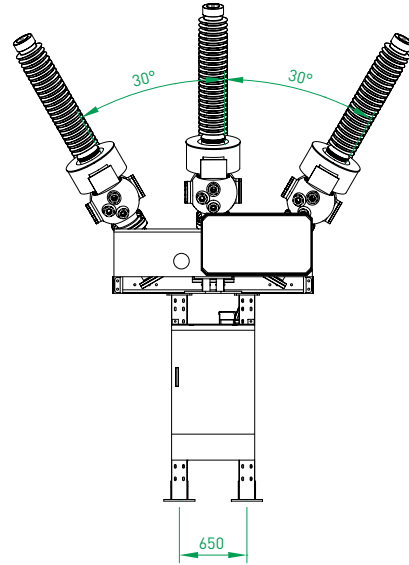
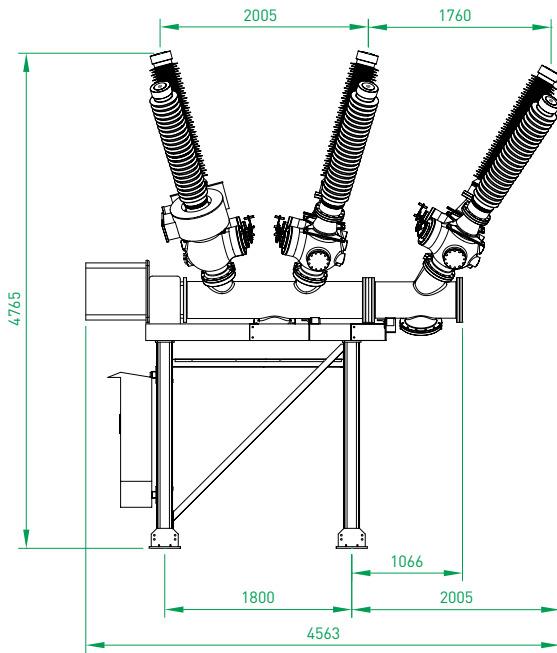

Foundation with double busbar

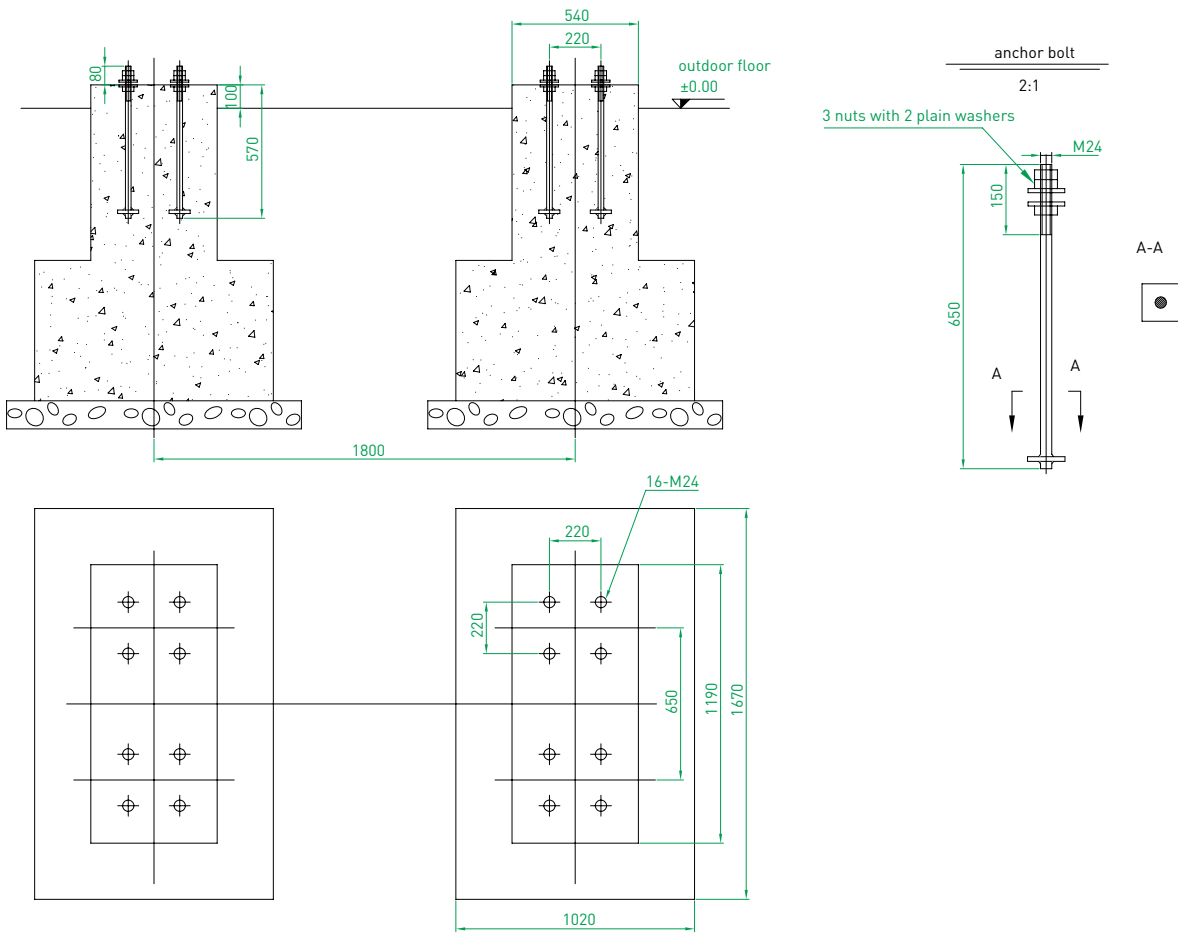

Note:

1. The anchor bolts shall be made of Q235-A steel. Chamfer the ends of thread area (2 x 45°); surface roughness of thread area is Ra6.3, the value for the rest area is Ra25. The fillet weld height of bottom square board > 8mm; all parts shall be treated with thermal galvanization, the zinc-layer thickness shall be greater than 85µm. The dimension requirements are for product after galvanization.
2. The length of the exposed part of the embedded M24 anchor bolt shall be 80mm; dimension tolerance of anchor bolt is +1mm.
3. Dimension template can be used during the assembly of M24 anchor bolt to ensure the dimension tolerance.
4. The foundation drawing is only for reference. The construction drawing must be designed according to local geological conditions.

## Electrical diagram

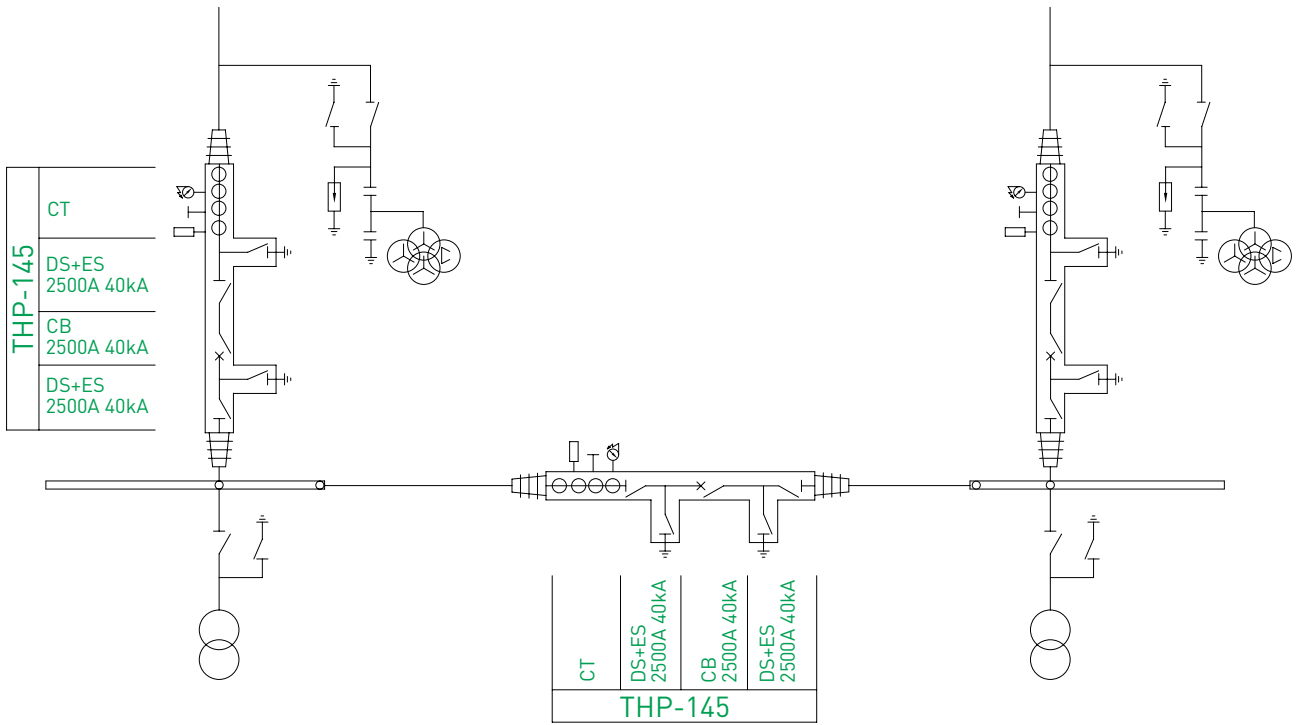

Layout

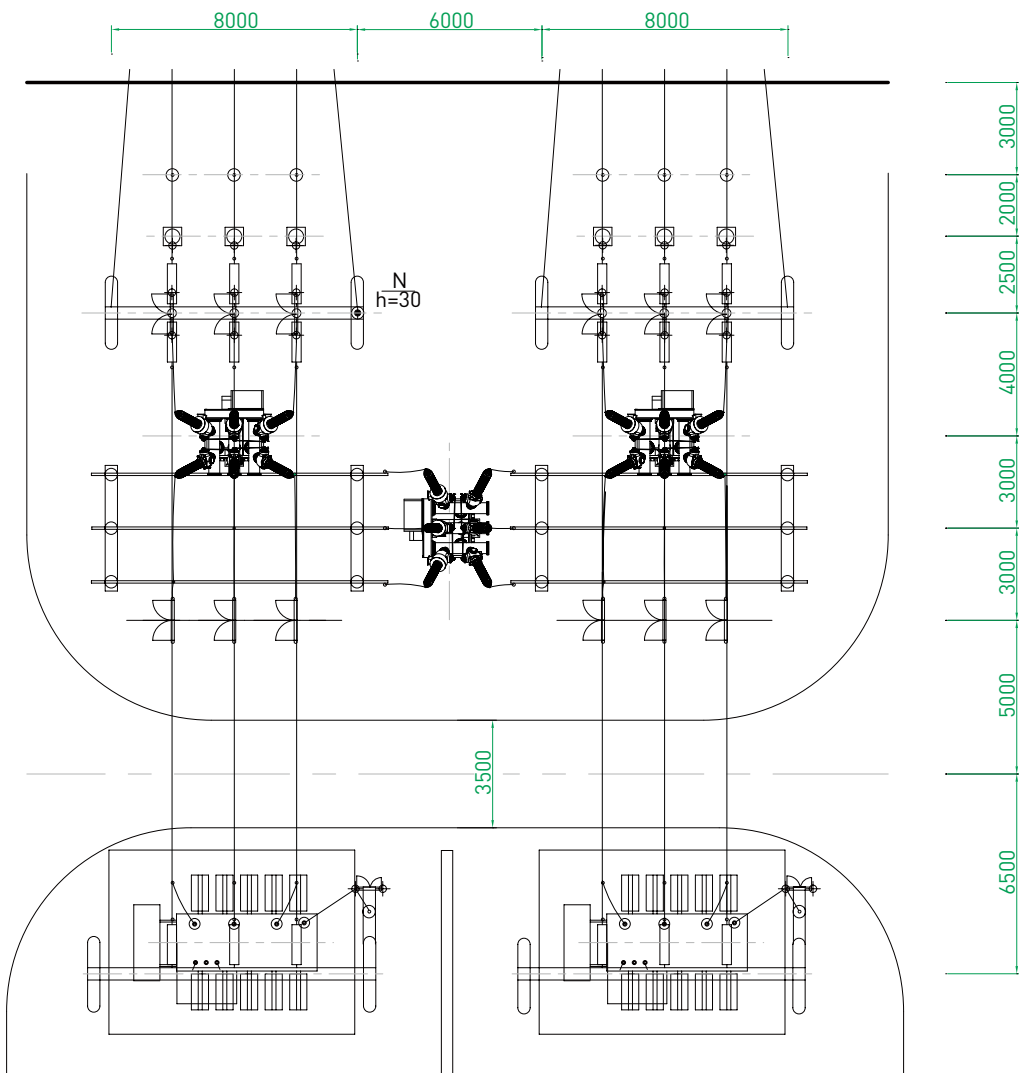

Section drawing

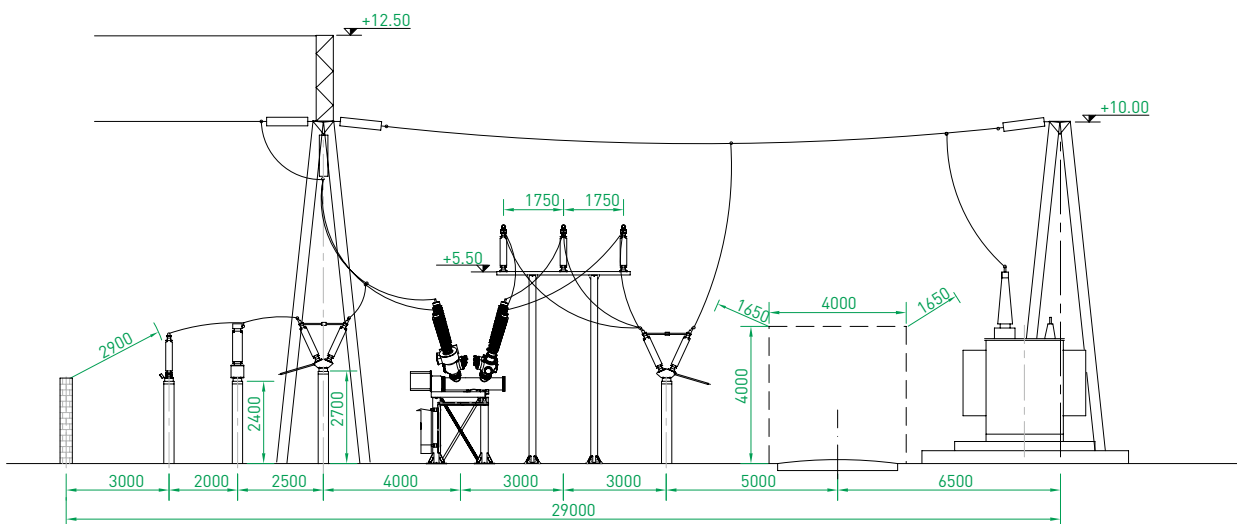

## Electrical diagram

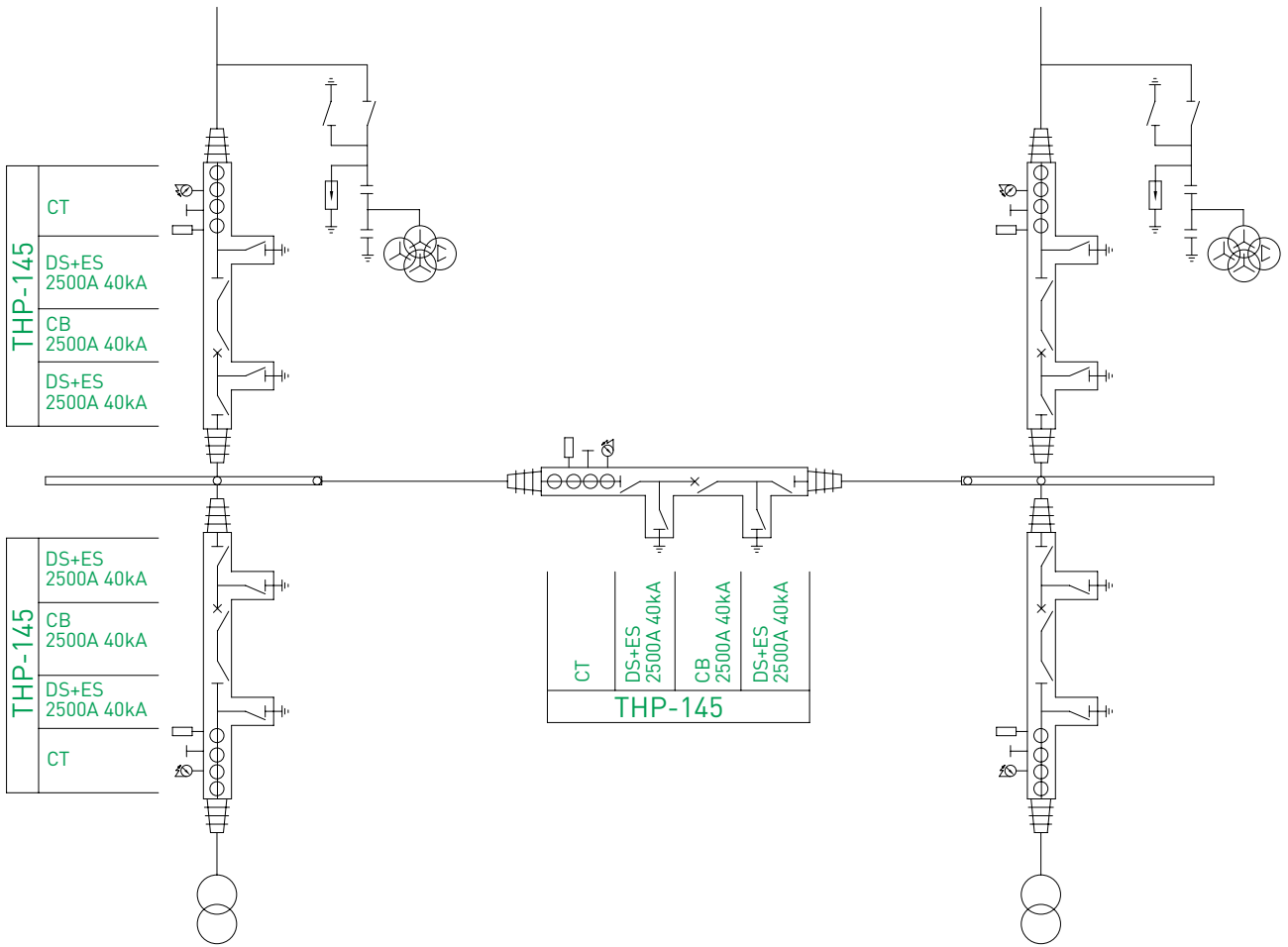

Layout

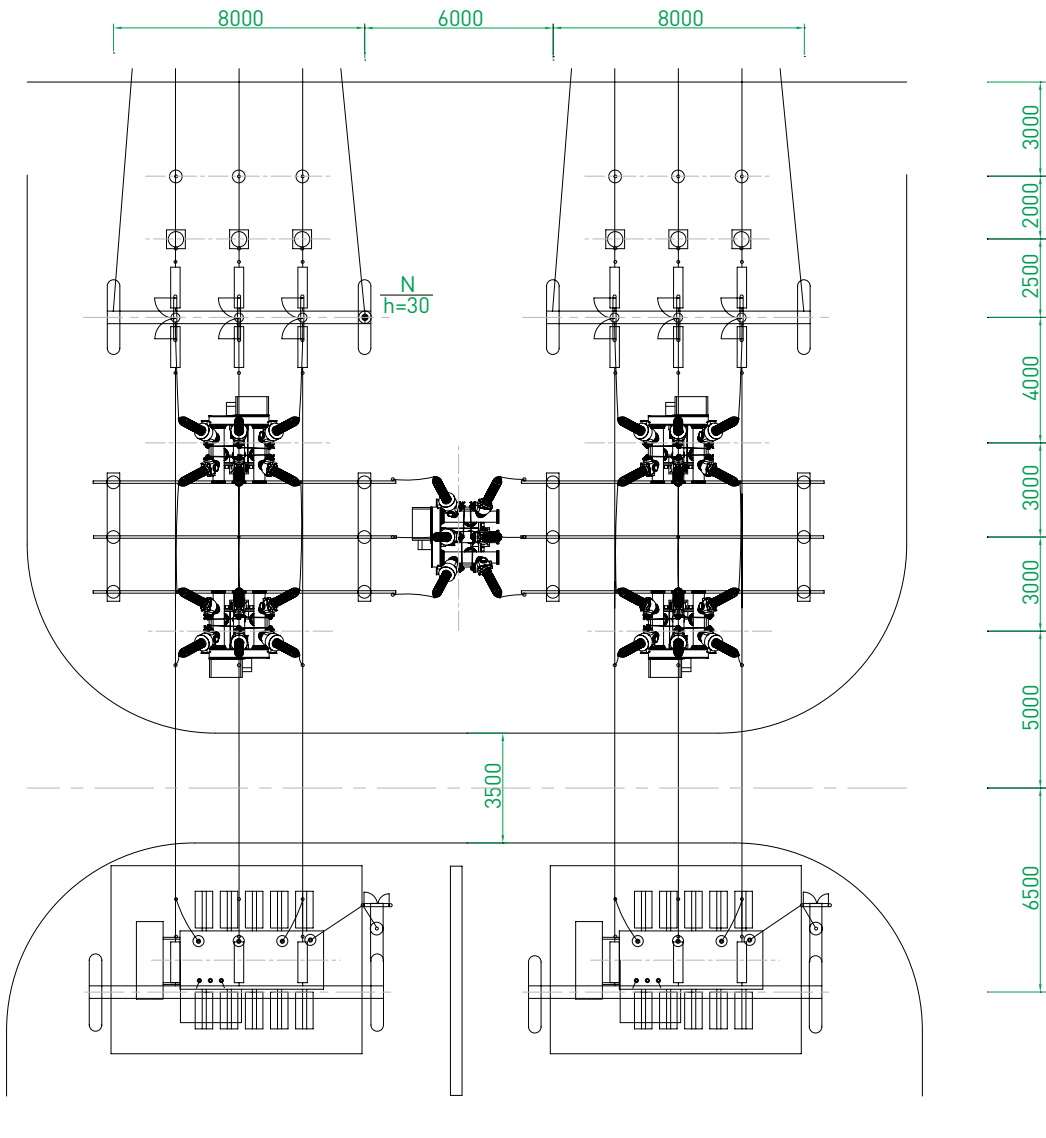

Section drawing

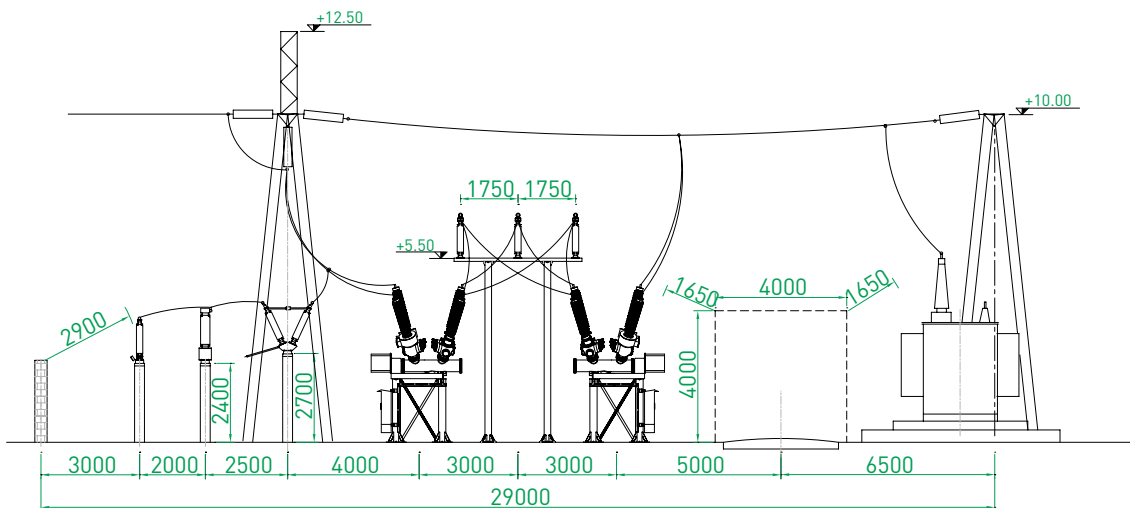

# An Example

# 145kV/40.5kV/6kV power substation

## Electrical diagram

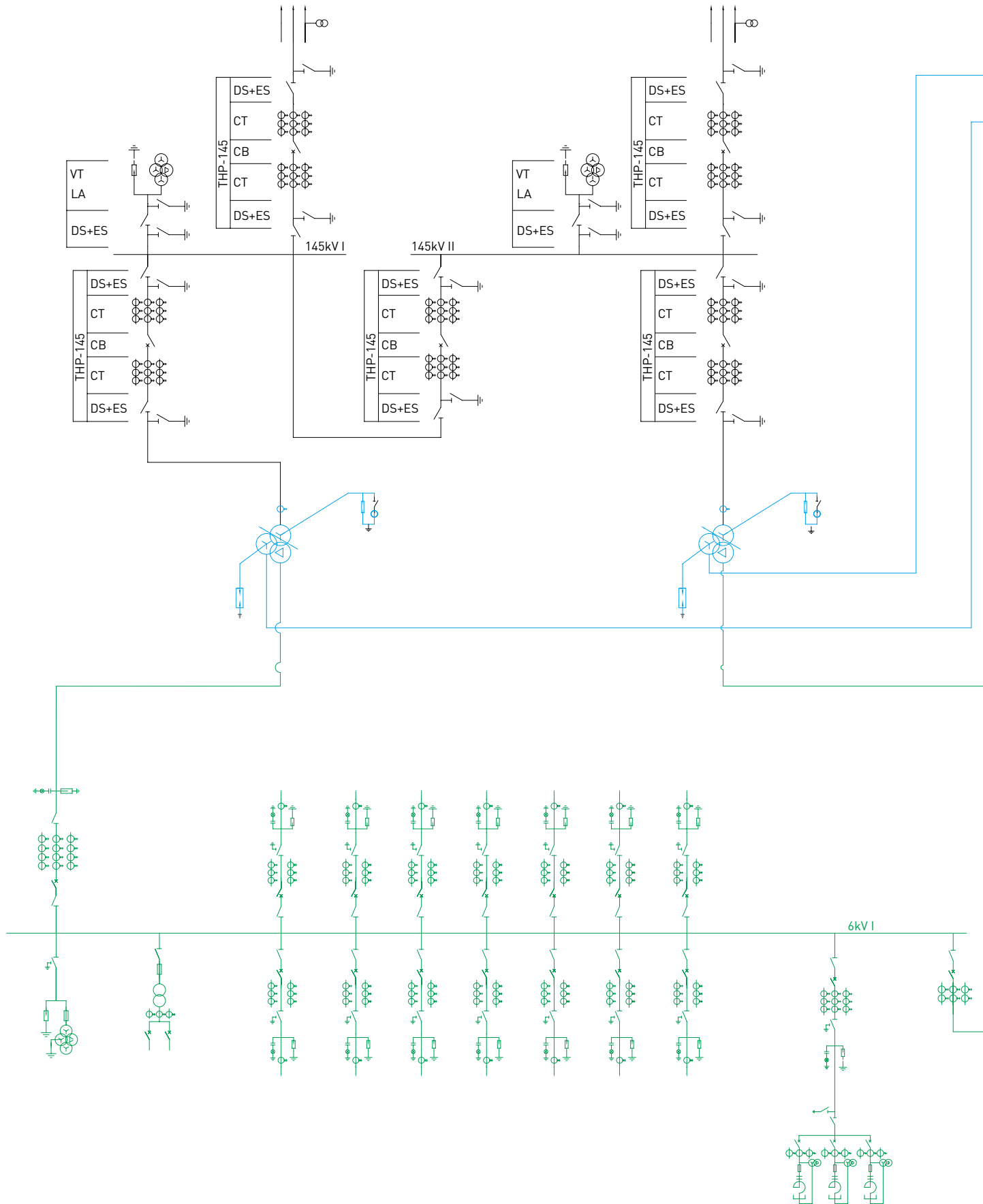



Electrical diagram

