



Smart Integrated

Model ZF-72.5(Z)/T1250-31.5

Catalogue 2026



COMPANY PROFILE

- Founded in 2004, TGOOD (Stock Code: 300001) was the first company listed on the Growth Enterprise Board of the Shenzhen Stock Exchange in 2009.
- The mission of TGOOD is to create the world's top brand of prefabricated power equipment
- TGOOD's intelligent modular prefabricated substations has occupied a 60% share of power grid and new energy markets.
- TGOOD has delivered product solutions to 6300+ customers, and provided 11,000+ prefabricated substations.
- TGOOD's prefabricated and integrated solutions have been implemented in 50+ countries and regions worldwide.

No.1

The world's No.1 brand of prefabricated substation equipment

The largest in the World

One of the largest supplier for prefabricated substation

The largest in China

TGOOD is the largest R&D and production base for prefabricated substations in China

Only in China

The only manufacturer in China achieving digital, technological, specialized, and large-scale production of prefabricated substation.

Champion

MIIT manufacturing industry single item champion enterprise

Four Main Manufacture Factories



Sichuan Chengdu Manufacturing Factory



Hubei Yichang Manufacturing Factory

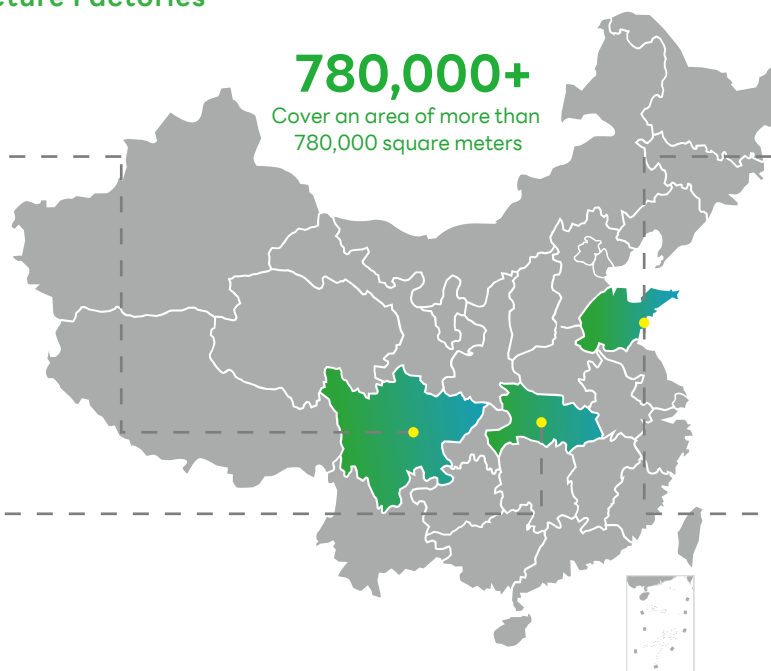

Qingdao West Coast Manufacturing Factory



Qingdao Free Trade Zone (China)

Model ZF-72.5(Z)/T1250-31.5

| Application Scenarios



New Energy



Transport

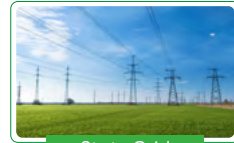

State Grid



Petrochemical



Rail Transport



Power Distribution

Table of Contents

Company Profile	2
Products	4
Product Overview	4
Features	5
Product Features	5
Technical Data	6
Operating Environment	6
Main Functional Components	7
Cable joint structure	7
Cable Ring Core Current Transformer	7
Temperature Regulator for Control Cabinet	8
Cable Connection Compartment	8
Configuration Scheme	9
One In, Two Out	10
One In One Out	10



Model ZF-72.5(Z)/T1250-31.5



Product Overview

Model ZF-72.5(Z)/T1250-31.5, a key device in response to the national strategic goal of “carbon peaking and carbon neutrality”, truly achieves “zero-carbon” emissions by adopting vacuum interrupters and using dry air as the insulating gas. It is applicable to: inside the offshore and onshore wind turbine towers with 72.5 kV voltage network; outside and inside kiosks for the offshore and onshore photovoltaic power generation with 72.5 kV voltage network; outside and inside kiosks for the offshore and onshore photovoltaic energy storage systems with 72.5 kV voltage network;



Typical Applications

- ▶ IEC 62271-203: High-Voltage Switchgear and Controlgear - Part 203: AC Gas-Insulated Metal-Enclosed Switchgear for Rated Voltages Above 52 kV
- ▶ IEC 62271-1: High-Voltage Switchgear and Controlgear - Part 1: Common Specifications for Alternating Current Switchgear and Controlgear
- ▶ IEC 62271-100: High-Voltage Switchgear and Controlgear - Part 100: Alternating-Current Circuit-Breakers
- ▶ IEC 62271-102: High-Voltage Switchgear and Controlgear - Part 102: Alternating-Current Disconnectors and Earthing Switches
- ▶ GB/T 7674 Gas-Insulated Metal-Enclosed Switchgear for Rated Voltages of 72.5 kV and Above
- ▶ GB/T 11022 Common Specifications for High-Voltage Alternating-Current Switchgear and Controlgear Standards
- ▶ GB/T 1984 High-Voltage Alternating-Current Circuit-Breakers
- ▶ GB/T 1985 High-Voltage Alternating-Current Disconnectors and Earthing Switches
- ▶ JB/T 8738 Vacuum Interrupter Used in High-Voltage Alternating-Current Switchgear
- ▶ JB/T 3855 High-Voltage Alternating-Current Circuit Breaker

Product Features

Environment Friendliness

- With the insulating medium being clean air which is non-toxic, non-flammable, stable, and free of carbon decomposition risks in the switch or insulating gas compartments, the GIS has zero greenhouse potential (GWP=0).
- The vacuum interrupter adopts the vacuum interruption technology and generates no greenhouse gas emissions during operation, maintenance, or recycling processes, so that the switching medium (vacuum) has zero greenhouse potential (GWP=0).

Strong Environmental Adaptability

- The medium in the vacuum interrupter does not liquefy. Clean air, as the insulating medium, has a low boiling point and will not liquefy at low temperature applications. It can operate reliably in extreme environmental conditions.

Safety and Maintenance-Free

- The sealed vacuum interrupter is highly reliable and maintenance-free during operation.
- The use of clean air (a non-fluorinated gas) as the insulating medium has the lowest requirements for transportation, installation, operation and recycling. No gas recovery is required, which ensures high operational safety.
- With an anti-arcing classification of IAC 31.5kA/0.5s, the product is designed with a dedicated arcing pressure relief channel that ensures the safety of operators even in the event of potential arcing incidents.

Reliable Breaking Performance

- The mature vacuum interruption technology allows for frequent short-circuit current breaks and offers excellent switching characteristics throughout the service life of the vacuum interrupter.

Modular and Intensive Design

- The intensive GIS solution enables the circuit breaker, disconnectors, and earthing switch to share a gas compartment. The entire section is pre-assembled, tested, and transported as a complete unit to simplify cable connections, with all typical bays and arrangements maintaining the same size.
- Flexible design is adopted based on the single line diagram of the switchgear inside the tower and specific project requirements. The GIS meets the space layout requirements of both the conventional indoor power distribution room and the outdoor kiosks;



Environment friendliness



Modular and compact design



Reliable breaking performance

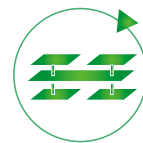

Safety and maintenance-free



High environmental adaptability

Technical Data



Operating Environment

- **Installation location:** Indoor or outdoor;
- **Ambient temperature:** -25 °C to 40 °C (-45 °C to 55 °C for special requirements);
- **Altitude:** ≤1000m (special orders are not limited);
- **Air humidity:** daily average ≥ 95%, monthly average ≥ 90% (at 25 °C);
- **Wind speed:** ≥ 35m/s (wind pressure not exceeding 700 Pa);
- Seismic fortification intensity = 9 degrees: horizontal acceleration ≤ 0.5 g, and vertical acceleration ≤ 0.25 g.

Main Technical Data	Unit	Value
Rated voltage	kV	72.5
Rated current	A	1250
Rated short-circuit breaking current	kA	31.5
Rated short-time withstand current	kA	31.5
Rated short-time withstand current peak	kA	80
Rated frequency 1 min withstand voltage (disconnection)	kV	160+42
Rated lightning impulse withstand voltage peak value (disconnection)	kV	380+59
Gas leakage rate		0.1%
Insulating medium in gas compartment	MPa	Dry air
Rated inflation pressure		0.5
Degree of protection		IP55W
Corrosion resistance category		C5-H



Main Functional Components



Cable joint structure

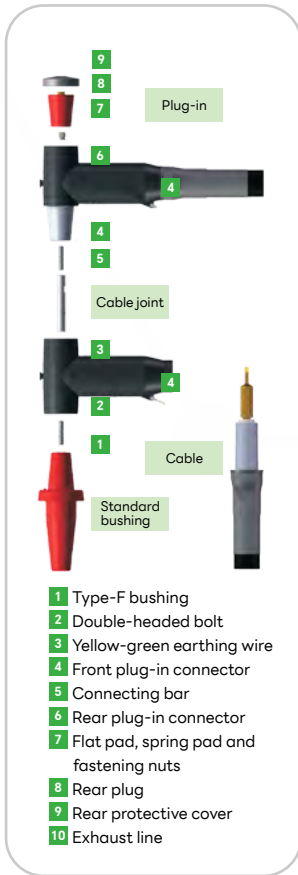

- Bushings, cable joints, and plug-in surge arresters are purchased as a whole, and cable joints and surge arresters are installed on site.
- Parameters of bushings and cable joints: Rated voltage: 72.5 kV; Rated current: 1,250 A;
- Parameters of surge arrester:
 - Rated voltage: 84 kV; Continuous operation voltage: 67.2 kV;
 - Residual voltage under lightning impulse current: ≤ 221 kV;
 - Residual voltage under steep impulse current: ≤ 254 kV;
 - Residual voltage under operational impulse current: ≤ 188 kV;
 - Partial discharge value at 1.05 times U_c : ≤ 10 pC.



Cable Ring Core Current Transformer

- Mature technology and wide application
- Compact structure and flexible arrangement
- No limitation by voltage, and compliance with capacity requirements
- Integral casting, metal enclosure, moisture resistance, and excellent anti-corrosion performance.

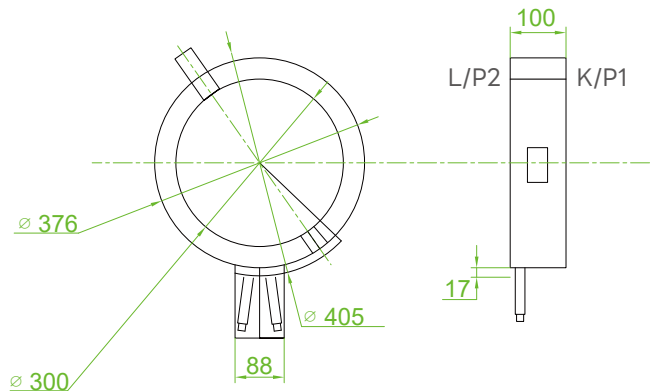
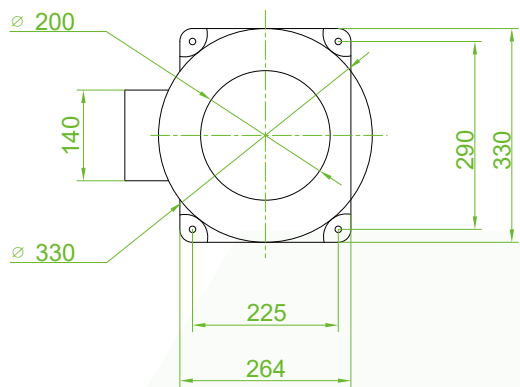
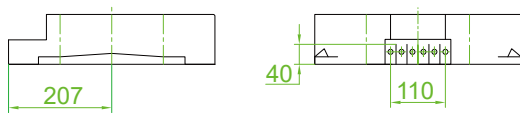

Main Functional Components



Temperature Regulator for Control Cabinet

- Condensation prevention in the mechanism box and cable connection compartment
- **Pickup value:** Temperature: starting below 5 °C, and shutting off above 15 °C;
- **Humidity:** starting above 85%, and shutting off below 75%
- **Scheme 1:** Cabinet air conditioner (479*797*155) installed inside the control cabinet which is sealed as a whole
- **Scheme 2:** Temperature and humidity controller + heater + fan + dehumidifier



Cable Connection Compartment

- The total height of the cable connection compartment is 2,300 mm, with an arc-release vent set at the top to prevent damage to surrounding personnel and equipment in the event of a cable failure;
- Cables are arranged in a linear layout to reduce the interval width and outgo vertically upward or downward to avoid stress on the cable terminations;
- The installation position has been set for the current transformer;
- Detachable structure facilitates cable installation;
- Internal fault anti-arcing capability offers high reliability.

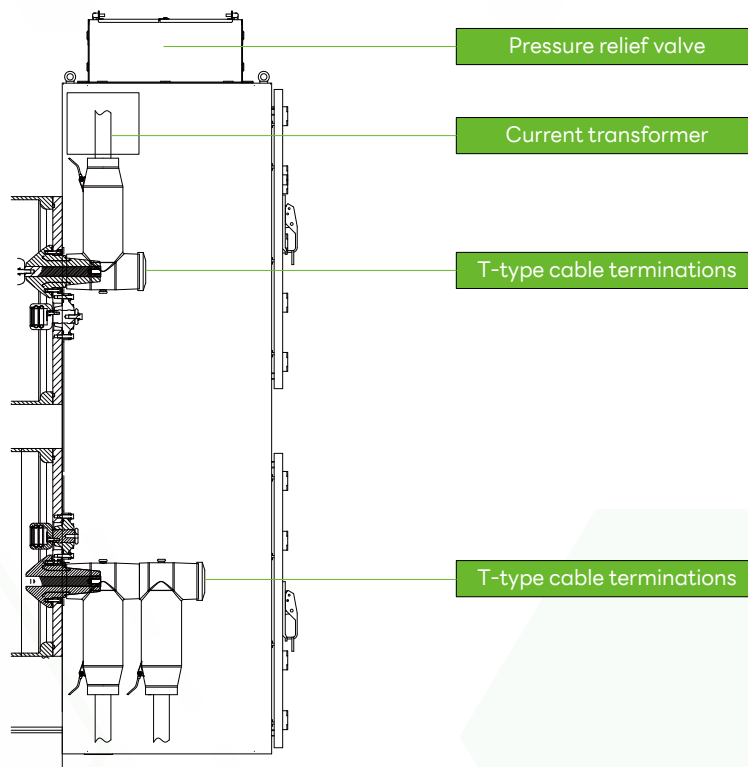

Configuration Scheme

Incoming cable of transformer

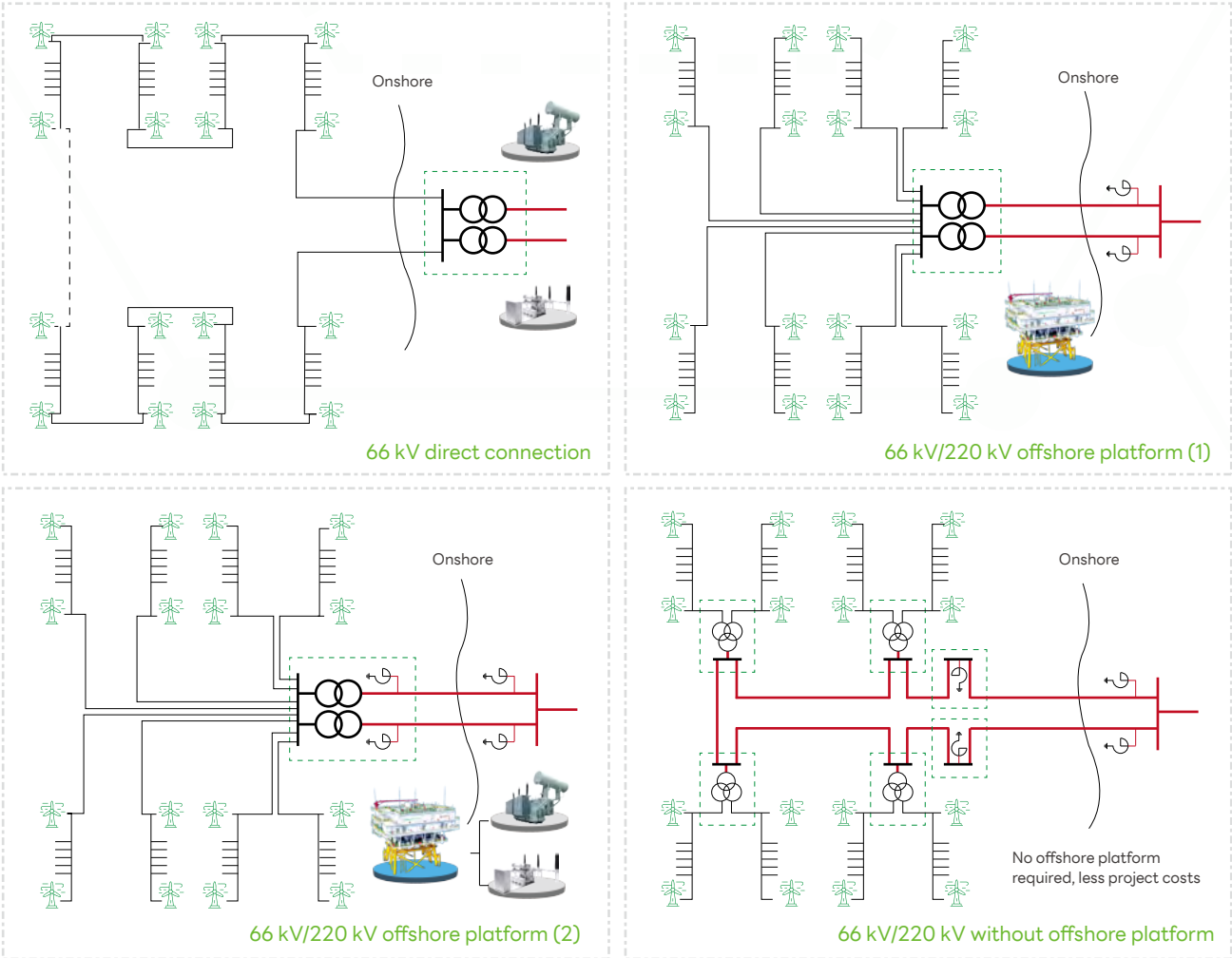

Main Wiring Diagram

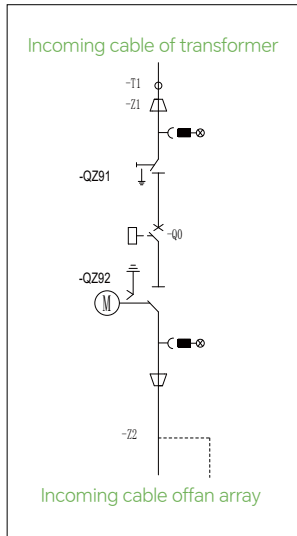
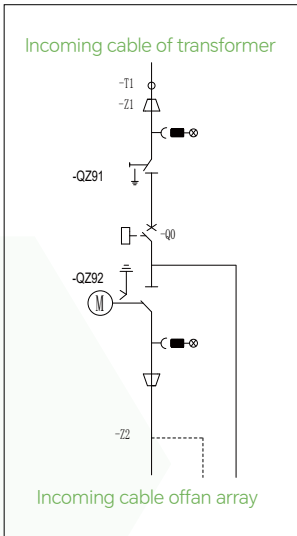
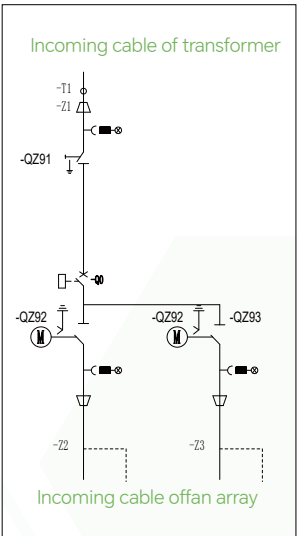

One In, Two Out

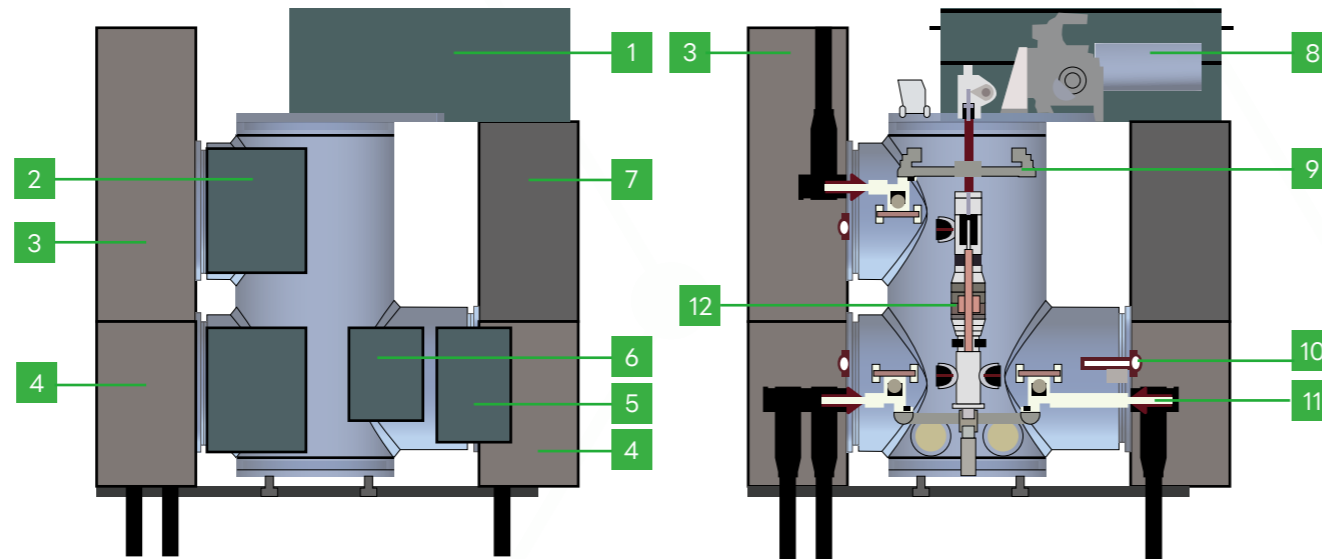
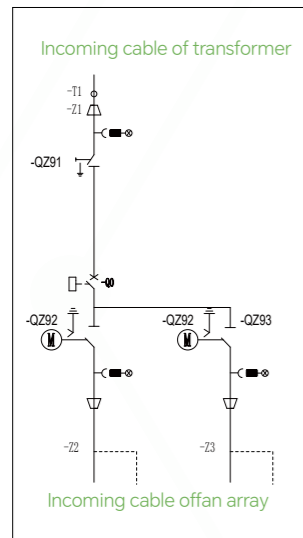

- 1 Spring operating mechanism
- 2 DES electric operating mechanism
- 3 Cable at fan side
- 4 Cable at seabed side
- 5 FES operating mechanism
- 6 DS operating mechanism
- 7 Control cabinet
- 8 Sub-box and arm boxes
- 9 Three work-position disconnecting earthing switch (DES)
- 10 Fast earthing switch
- 11 Disconnecter
- 12 Vacuum interrupter

One In One Out

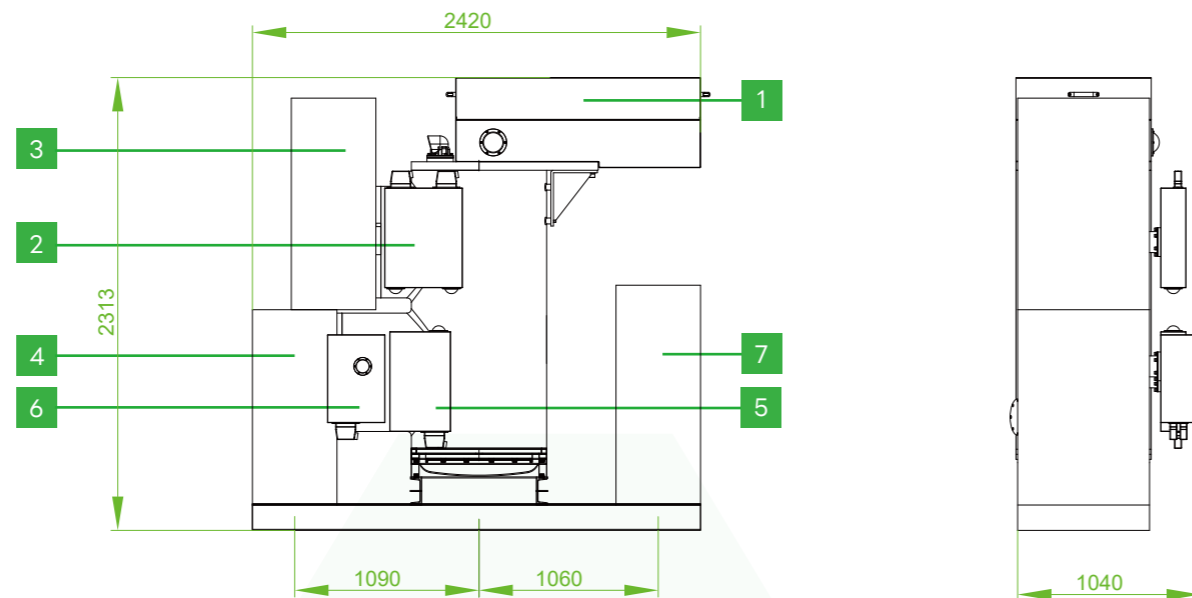
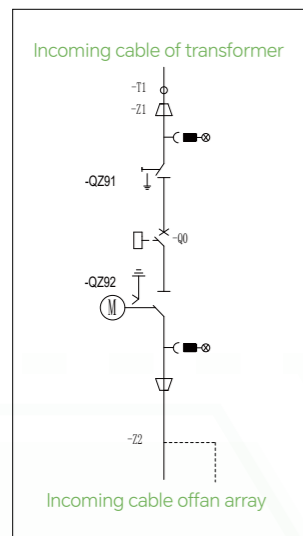

- 1 Spring operating mechanism
- 2 DES electric operating mechanism
- 3 Cable at fan side
- 4 Cable at seabed side
- 5 ES operating mechanism
- 6 FES operating mechanism
- 7 Control cabinet

- Volume and weight are optimized according to the parameters required by the wind power system, leading to a more compact layout and more integrated structure.
- The modular characteristics of GIS are fully leveraged to achieve flexible design based on the SLD of the switchgear inside the tower and specific project requirements.
- Equipment size: 1040*2420*2313 (including cable connection compartment), directly accessible through the tower door, and convenient for maintenance and replacement.

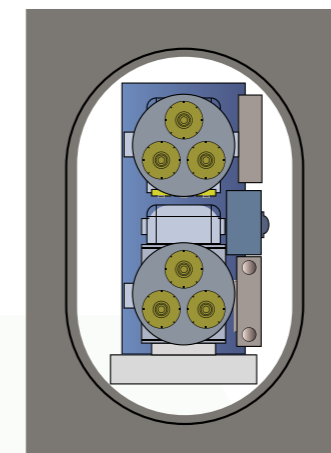

The tower door is 2100×1300 as shown in the schematic diagram.

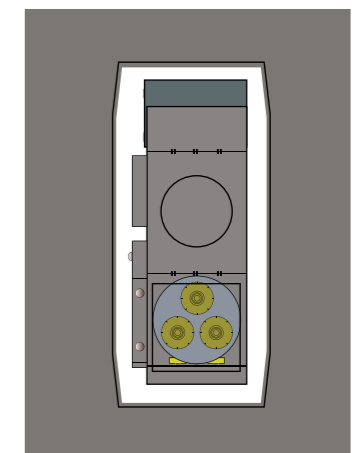

The tower door is 2460×1090 as shown in the schematic diagram.



**POWERING GLOBAL ENERGY TRANSITION,
FULFILLING TGOOD COMMITMENT**

TGOOD ELECTRIC(300001.SZ)

Address: No.336 Songling Road,Laoshan District,Qingdao,China
Website:www.qdtgood.com E-mail: info@qdtgood.com
Tel: +86 532 8908 8929 Fax: +86 532 8908 3066