

HYGN01-20251231



www.qdtgood.com

QINGDAO TGOOD ELECTRIC CO.,LTD.
TGOOD ELECTRIC(300001.SZ)

Address: No.336 Songling Road,Laoshan District,Qingdao,China

E-mail: info@qdtgood.com

Tel:+86 532 8908 8929

Fax:+86 532 8908 3066



Vacuum Cast Coil Dry-type Transformers



www.qdtgood.com



Company Profile

- > Founded in 2004, TGOOD (Stock Code: 300001) was the first company listed on the Growth Enterprise Board of the Shenzhen Stock Exchange in 2009.
- > The mission of TGOOD is to create the world's top brand of prefabricated power equipment.
- > TGOOD's intelligent modular prefabricated substations has occupied a 60% share of power grid and new energy markets.
- > TGOOD has delivered product solutions to 6300+ customers, and provided 11,000+ prefabricated substations.
- > TGOOD's prefabricated and integrated solutions have been implemented in 50+ countries and regions worldwide.

No.1

The world's No.1 brand of prefabricated substation equipment

The largest in the World

One of the largest suppliers of prefabricated substation

The largest in China

TGOOD is the largest R&D and production base for prefabricated substations in China

Only in China

The only manufacturer in China achieving digital, technological, specialized, and large-scale production of prefabricated substations

Champion

MIT manufacturing industry single item champion enterprise

Four Main Manufacture Factories

Cover an area of more than **780,000** square meters



Table of Contents

Company Profile	02
2 Product Overview	05
2.1 Application Scenarios	05
2.2 Reliable Solutions for All Applications	06
2.3 Certified High Performance for Enhanced Safety and Reliability	07
2.4 Certifications	07
3 Technical Data	08
3.1 Features	08
3.2 Product Advantages	09
3.3 Core Cutting and Stacking	10
3.4 High Voltage Winding	12
3.5 Low Voltage Winding / Foil Winding	14
3.6 Coil Casting	16
3.7 Coil Solidification	18
3.8 PEI Values for Dry Type Transformers with $U_m \leq 36$ kV and $S_r \leq 3150$ kVA	20
3.9 Maximum Load Loss and Maximum No Load Loss for Transformers with Rated Frequency Equal to 50 Hz	21
3.10 Rated Voltage ≤ 12 kV Short-Circuit Impedance 6%	22
3.11 Rated Voltage 17,5 kV and 24 kV Impedance Voltage 6%	23
3.12 Rated Voltage 36 kV Impedance Voltage 6%	24
3.13 Rated voltage 35 kV Dry-type Power Transformer(NLTC)	25
3.14 Rated voltage 35 kV Dry-type Power Transformer(OLTC)	26
3.15 Dimensions of Typical Ratings	27
Specification of TGOOD Dry-type Transformer	30
Certificates	31

2 Product Overview

2.1 Applicable Standards

- IEC 60076.1-2011 General Power transformers
- IEC 60076.2-1993 Temperature rise
- IEC 60076.3-2000 Insulation levels, dielectric tests and external clearances in air
- IEC 60076.5-2000 Ability to withstand short circuit
- IEC 60076.11-2004 Dry-type transformer
- BS EN 50541-1:2011 Three phase dry-type distribution transformers 50 Hz, from 100 kVA to 3150 kVA General requirements
- IEEE Std C57.12.91™ - 2011 Standard Test Code for Dry-Type Distribution and Power Transformers
- IEEE Std C57.12.01™-2005 IEEE Standard General Requirements for Dry-Type Distribution and Power Transformers, Including Those with Solid-Cast and/or Resin Encapsulated Windings

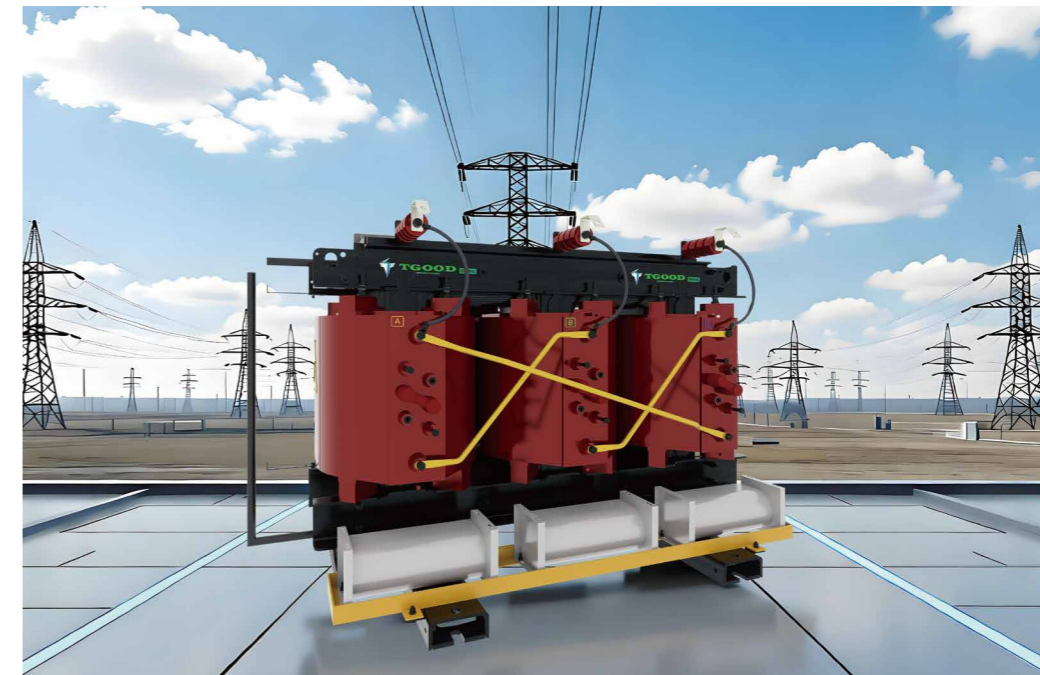

2.2 Reliable Solutions for All Applications



TGOOD has expertise in producing transformers for optimum space utilization, special requirements, and the most demanding conditions. We deliver the most comprehensive range of solutions across all applications, product categories, and customized projects.

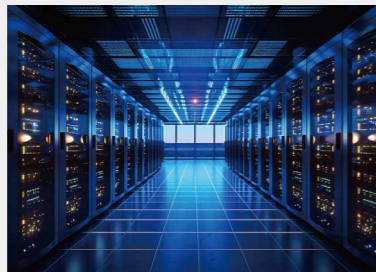

Data Centers



Marine



Wind Power



Solar Power



Railways



Hydrogen



Industries



Utilities

2.2 Certified High Performance for Enhanced Safety and Reliability



TGOOD offers the highest level of compliance to IEC 60076-11:2018. High performance comes as standard with fire safety and partial discharge helping to provide increased power continuity, even in the harshest environments, including seismic certification.

- Safety for People and Property
- No Fire Hazard
- Environmental Friendly
- Maintenance and Pollution Free
- Reduced Civil Works
- Enhanced Withstand to Short Circuit Stress
- Applicable for Damp and Contaminated Areas
- No Specific Fire Detection Systems (compact housings)
- Improved Performance against Seismic Phenomena

2.3 Certifications

F1 fire certification

- Self-extinguishing capability
- Suitable for installations in fire-hazard areas
- Limited formation of fumes, no toxic emissions
- or opaque smoke

E4 environmental certification

- Highly resistant to frequent condensation, heavy pollution or a combination of both
- Withstand humidity greater than 95%
- Extended service life, even in harsh environments

C4 climate certification

- Resistance to thermal shock
- Highest performance under severe ambient conditions
- Superior behavior on load changes

Partial discharge rating of ≤ 5 pC

- Proven quality design with best-in-class reliability
- Reduced risk of an electrical breakdown
- Slower equipment deterioration

3.1 Features

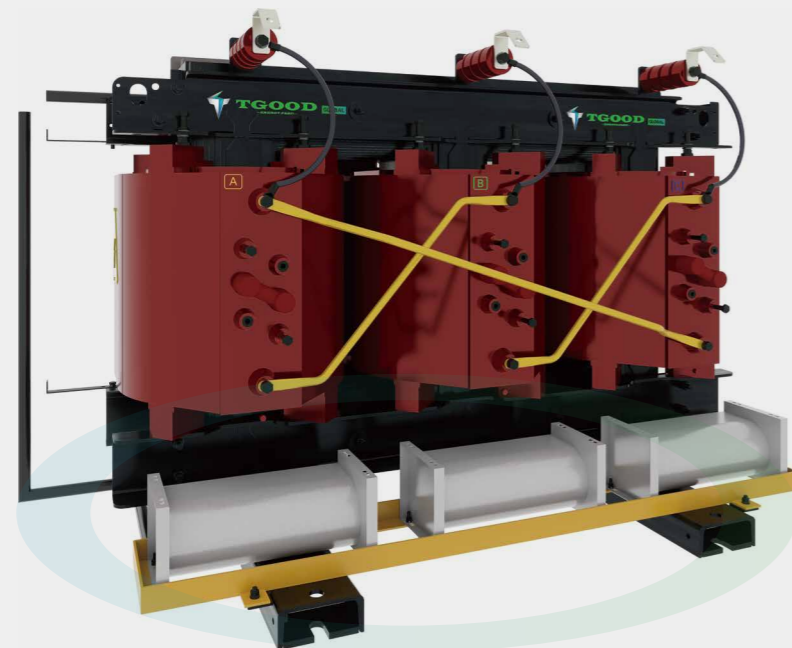

The most advanced seven-level step-by-step process in the industry, which involves stacking iron cores one by one



fully automatic Vacuum casting process



Adopting flame-retardant epoxy casting system



Low-level discharge



The low-voltage coil adopts a foil winding structure, and the digital coil winding equipment is used for high precision processing and manufacturing.



The high-voltage coil adopts an H-level insulation system, which is made of glass fiber reinforced insulated electromagnetic wires and electrical grids cast together.



3.2 Product Advantages

Excellent insulation and moisture resistance performance

- **Fully sealed structure**
X/Y/Z three-axis servo control, winding accuracy $\pm 0.1\text{mm}$, ensuring tight and uniform turns.
- **High dielectric strength**
Epoxy resin has a high dielectric constant, low partial discharge ($\leq 10\text{pC}$), and an insulation life of over 20 years.
- **Oil free design**
Eliminate leakage and fire risks of oil-immersed transformers, in compliance with environmental protection requirements.

Mechanical strength and short-circuit resistance

- **Rigid protection**
After curing, the epoxy resin forms a high-strength shell that can withstand short-circuit electric forces (up to $25\text{ kA} / 2\text{ s}$) and prevent winding deformation.

Fire prevention and environmental protection characteristics

- **High flame retardant rating**
The combustion level meets F0.
- **Pollution-free**
Does not contain harmful substances such as PCS, with a recycling rate of over 90%.

Low maintenance and long lifespan

- **Maintenance-free**
Oil-free and moisture-absorbing materials, only need to be cleaned daily, with operation and maintenance costs more than 60% lower than oil-immersed ones.
- **Anti aging**
Epoxy resin is resistant to ultraviolet radiation and chemical corrosion, and can be directly installed for outdoor use (Ip54). Oil-free and moisture-absorbing materials, only need to be cleaned daily, with operation and maintenance costs more than 60% lower than oil immersed ones.

Adapt to complex environments

- **Anti-pollution measures**
The pouring surface is smooth and dust is not easily attached, suitable for dust and salt spray environments (such as coastal subways and chemical plants).
- **Wide temperature operation**
Reliable operation at ambient temperatures ranging from $40\text{ }^\circ\text{C}$ to $+50\text{ }^\circ\text{C}$ (special formula resin can be extended to $-60\text{ }^\circ\text{C}$).

3.3 Core Cutting and Stacking

The iron core cutting line has one set of industry-leading intelligent and automated vertical cutting equipment, two sets of horizontal cutting equipment, and is equipped with multiple high-precision stacking platforms, as well as fully automatic flipping platforms, fully sealed iron core surface treatment rooms that meet environmental requirements, and drying rooms. It can meet the complete set of operations for cutting, automatic stacking, and overall stacking of iron cores of different thicknesses of silicon steel coils, as well as completing overall surface treatment.



EQUIPMENT ADVANTAGES

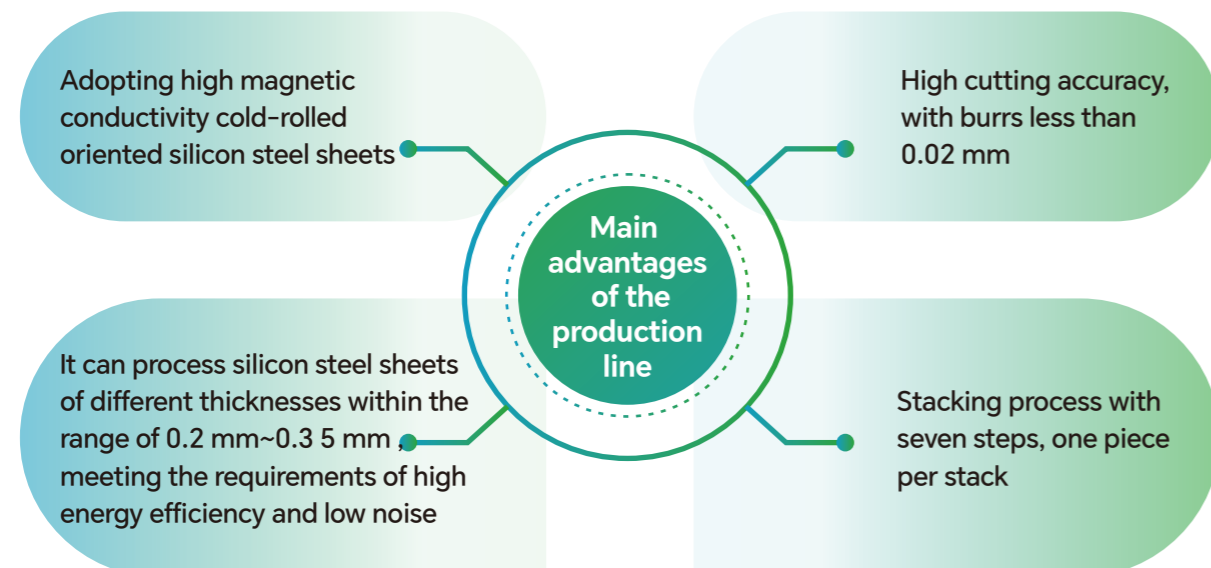

3.3 Core Cutting and Stacking

PRODUCT FEATURES

Reduce Iron Core Loss

- **Reduce hysteresis loss**
Shear stacking reduces magnetic flux by optimizing the seam structure of laminated panels (such as diagonal or stepped seams) The path distortion at the joint reduces local magnetic resistance, thereby reducing hysteresis loss.
- **Reduce eddy current losses**
The laminations are tightly adhered and have good insulation, effectively suppressing the generation of eddy currents and improving the efficiency of the iron core.

Improve Magnetic Flux Distribution

- **Uniform magnetic circuit**
The stepped seam design ensures a more uniform distribution of magnetic flux in the iron core, avoiding local magnetic flux concentration or saturation caused by traditional straight seams, and reducing no-load current and noise.
- **Reduce magnetic leakage**
Optimizing the joint shape can reduce magnetic leakage and improve the energy transmission efficiency of transformers.

Reduce No-Load Noise

- **Reduce magnetostrictive vibration**
make the transformer run quieter (can reduce noise by 3-5 dB).

Long Term Reliability

- **Reduce local overheating**
Uniform magnetic flux distribution avoids hot spots, prolongs insulation material life, and improves transformer reliability

3.4 High Voltage Winding

The high-voltage coil of the epoxy cast dry-type transformer adopts the epoxy resin vacuum casting process, which gives it excellent electrical performance, mechanical strength, and environmental protection characteristics. It is widely used in data centers, rail transit, new energy generation and other fields.



PRODUCT FEATURES

Electrical Insulation

- After curing, epoxy resin forms a solid insulation layer with high dielectric strength, effectively isolating high-voltage conductors and preventing discharge and breakdown.
- Suitable for voltage levels of 10 kV~35 kV, with low partial discharge capacity (usually ≤ 10 pC).

Mechanical Support and Protection

- The cured epoxy resin wrapped coil enhances overall mechanical strength, resistance to impact and vibration, and is suitable for harsh environments such as ships and mines.
- Prevent the coil from getting damp and dust from entering, and improve long-term reliability.

Heat Dissipation Optimization

- The thermal conductivity of epoxy resin (~ 0.2 W/m·K) is better than that of air, and with the design of internal heat dissipation channels, it improves the temperature rise control capability (F/H insulation, allowing operation at 155 °C~180°C).

3.4 High Voltage Winding

EQUIPMENT ADVANTAGES



Automatic adjustment of winding tension



High dimensional accuracy in winding



Digital control of winding process parameters



Digital manufacturing of coils supported by mes system



Automatic Adjustment of Winding Tension: Ensuring Stable Winding Tension of The Coil

The drawbacks of traditional manual adjustment

- Tension fluctuations cause uneven tension in the coil, affecting insulation performance and heat dissipation
- Over tension strains the wire, while over looseness causes the coil to become loose and deformed

The core goal of automatic adjustment

Maintain a constant tension (within $\pm 5\%$) to adapt to different wire diameters, materials, and winding speeds

High Dimensional Accuracy in Winding

- Ensure the accuracy of coil winding, reduce coil size deviation, minimize magnetic leakage, reduce winding eddy current losses, and improve the ability of transformer windings to withstand external shortcircuit electric forces

Digital Manufacturing of Coils Supported by Mes System

- The issuance and execution of instructions are digitized to reduce deviations and risks caused by human interference

Digital Control of Winding Process Parameters

- Reduce the risk of misoperation and improve quality reliability

3.5 Low Voltage Winding / Foil Winding

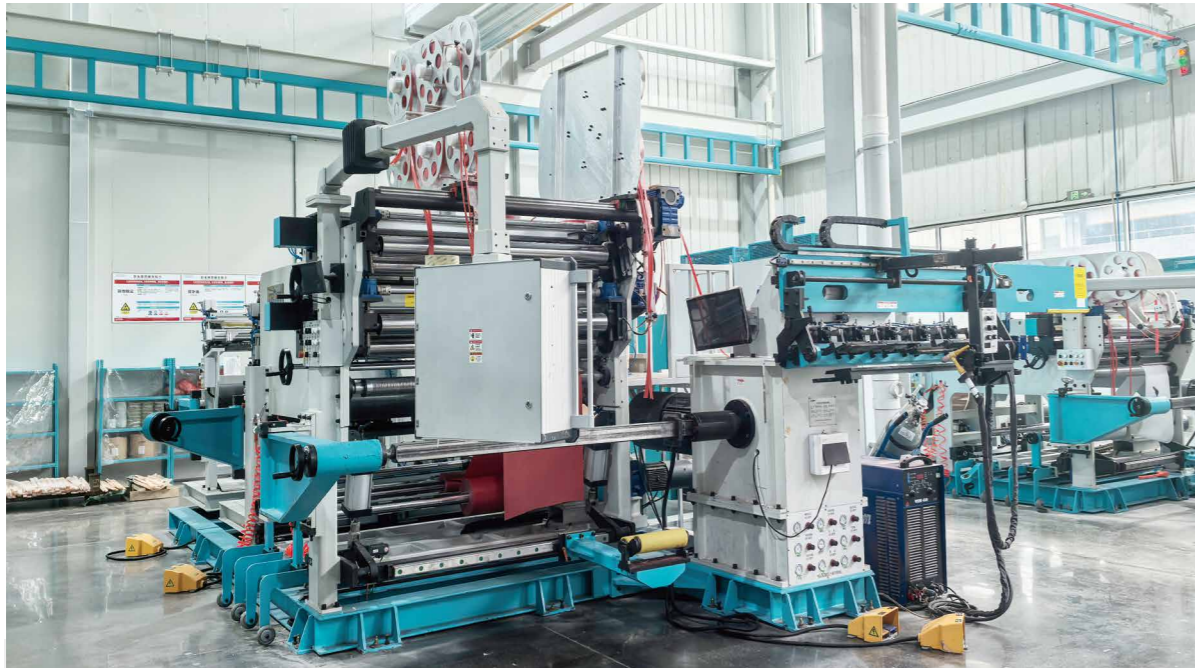

The foil wound coils of dry-type transformers are made of copper foil or aluminum foil as conductors, wound through special processes, and have the characteristics of compact structure, good heat dissipation performance, and strong short-circuit resistance. They are widely used in power distribution, industry, new energy and other fields.



Efficient



High-Precision



Low-Loss

EQUIPMENT ADVANTAGES

Accuracy	± 0.1 mm opposite edge	Above ± 0.5 mm
Automation	Fully automatic correction/skill count	Manual adjustment is mostly used
Efficiency	50 meters per minute (max)	20-30 meters per minute

3.5 Low Voltage Winding / Foil Winding

PRODUCT FEATURES



Conductor Materials and Structures

Copper foil/aluminum foil conductor:

Using high-purity electrolytic copper foil or aluminum foil (thickness 0.1-3mm), with excellent conductivity (copper foil conductivity \geq 58MS/m). It can reduce eddy current losses and improve current carrying capacity.

Multi layer continuous winding:

The foil strip and insulation material are alternately stacked to form a coil structure with strong integrity and no joints.



Excellent Heat Dissipation Performance

Horizontal heat dissipation channel:

Reserved ventilation gaps between foil wound coils, with a heat dissipation area 30%-50% larger than that of wire wound coils, and lower temperature rise.

Uniform heat distribution:

Wide width foil strips reduce the generation of hot spots and are suitable for high current applications.



Mechanical Strength and Short-Circuit Resistance

Strong integrity:

Epoxy resin vacuum casting or prepreg curing treatment forms a rigid whole of the coil, which is resistant to shortcircuit electric force.



Electrical Performance Advantages

Low eddy current loss:

The width of the foil strip is large, the skin effect is weak, and the additional loss is 20% to 30% lower than that of a wire wound coil.

3.6 Coil Casting

Epoxy resin vacuum casting is the core process for manufacturing high-voltage coils of dry-type transformers. By impregnating and curing epoxy resin in a vacuum environment, a high-strength insulation structure is formed.



EQUIPMENT ADVANTAGES

Index	Static Mixing Vacuum Casting
Residual bubbles	<0.05%
Mixing uniformity	Fully automatic, 99.9% uniform
Pouring efficiency	3-8 hours (50% acceleration)



Fully Automated Pouring Process

Intelligent control system

- PLC+industrial computer, capable of storing over 100 formulas, automatically adjusting the mixing ratio (accuracy $\pm 0.3\%$) and pouring speed (0.5-20 kg/min).
- Real-time monitoring of vacuum degree, material temperature, and flow rate, automatic alarm for abnormalities (such as pipeline blockage and vacuum leakage).

Efficient defoaming

- Two stage vacuum defoaming: pre defoaming (-0.095MPa)+deep defoaming after pouring ($\leq 5\text{Pa}$), ensuring that the porosity after solidification is less than 0.05%.



Static Mixing Technology

Bubble-free mixing

- Using a multi-stage static mixer (spiral+honeycomb structure), Mixing uniformity $\geq 99.9\%$, avoid introducing bubbles
- through mechanical stirring. Mixing under vacuum environment (-0.1 MPa) reduces resin viscosity by 35% and has excellent permeability.

Accurate temperature control

- Dual channel PID temperature control (\pm). Prevent resin pre curing or insufficient reaction.

3.6 Coil Casting

PRODUCT FEATURES

Process Characteristics

Vacuum degassing

Eliminate bubbles and moisture inside the coil in a vacuum environment to ensure complete resin penetration and eliminate the risk of partial discharge.

Pressure impregnation

Inject epoxy resin under a pressure of 0.5~1.0 MPa to tightly fill the gaps between the conductors with insulation material, forming an air gap-free structure.

Segmented solidification

Adopting gradient heating curing (80 °C~130 °C) to form a dense three-dimensional cross-linked network of resin, improving mechanical and electrical properties.

High performance epoxy resin

Choose low viscosity, high thermal conductivity resin with a temperature resistance rating of F (155°C) or H (180 °C).

Nano modification technology

Add nano fillers such as Al_2O_3 and SiO_2 to enhance thermal conductivity (0.3~0.5 W/m·K) and crack resistance.

Environmentally friendly formula

Solvent-free, halogen-free, compliant with RoHS/REACH standards.

Strong integrity

After solidification, the coil becomes a rigid whole, with excellent resistance to shortcircuit electrostatics and seismic performance.

No gap insulation

Resin completely wraps the wire and interlayer insulation, with a partial discharge capacity of $\leq 5\text{pC}$.

Heat dissipation optimization

Built in ventilation duct, combined with resin thermal conductivity, excellent temperature rise performance.

Material Characteristics

Structural Characteristics

3.7 Coil Solidification



The precision of temperature control during the curing process of epoxy cast coils is crucial, which directly affects the mechanical and electrical properties as well as long-term reliability of the product.



Uniform temperature distribution
Inside the curing furnace



Fast response to temperature
Regulation



High precision furnace
Temperature control



Automation and intelligence of
Solidification process



EQUIPMENT ADVANTAGES

Uniform Temperature Distribution Inside the Curing Furnace



Circulating hot air system+flow guide design, temperature difference inside the furnace $\leq \pm 2$ °C, ensuring stable product curing quality.

Automation and Intelligence of Solidification Process



The temperature control curve is built into the equipment and backend control system, and corresponding curing process parameters are selected based on product characteristics.

High Precision Furnace Temperature Control



Under stable operating conditions, the deviation between the actual furnace temperature and the required temperature should not exceed ± 2 °C.

Fast Response to Temperature Regulation



PID intelligent regulation ensures that the actual temperature inside the furnace accurately follows the control requirements.

3.7 Coil Solidification

PRODUCT FEATURES

Avoid Internal Stress and Cracks Improve Mechanical Strength



The function of step solidification

- Slowly increase the temperature to gradually crosslink the resin and reduce local shrinkage.
- **Slow cooling:** Avoid resin "embrittlement" during rapid cooling and reduce the risk of cracking.

Effect

- It can reduce internal stress by more than 30% and increase bending strength by 15-20%.

Improve the Long-Term Heat Resistance of Castings



The role of precise temperature control

- The main curing temperature should be close to the target Tg value of the resin.
- The post-curing process further enhances the crosslinking density.

Effect

- The lifespan of the coil is extended in high temperature environments.

Process Consistency and Yield Improvement



- Automated temperature control system: PID algorithm controls ± 1 °C accuracy to ensure consistent curing curves for each batch.

- Reduce human error:** avoid overshoot or insufficient caused by manual temperature adjustment by operators.

Ensure Sufficient Curing and Optimize Electrical Performance



Effect

- The dielectric strength has increased from 15 kV/mm to over 20 kV/mm.
- Partial discharge initiation voltage (PDIV) to reduce the risk of corona discharge during operation.

3.8 PEI Values for Dry Type Transformers with $U_m \leq 36$ kV and $S_r \leq 3150$ kVA

Rated power kVA	$U_m \leq 24$ kV		24 kV $\leq U_m \leq 36$ kV	
	PEI level 1 %	PEI level 2 %	PEI level 1 %	PEI level 2 %
≤ 50	97,668	97,922	97,377	97,662
100	98,485	98,653	98,296	98,485
160	98,654	98,791	98,486	98,640
250	98,875	98,991	98,735	98,865
400	98,984	99,129	98,858	99,020
630	99,082	99,158	98,968	99,053
800	99,194	99,235	99,093	99,140
1000	99,253	99,291	99,160	99,203
1250	99,288	99,325	99,199	99,240
1600	99,332	99,366	99,248	99,287
2000	99,355	99,388	99,275	99,312
2500	99,386	99,418	99,309	99,345
3150	99,419	99,449	99,347	99,381

NOTE:

Although the values in this table have been developed from 50 Hz transformer data, they are also applicable to 60 Hz transformers.

IEC 60076-20 Recommended performance parameters.

3.9 Maximum Load Loss and Maximum No Load Loss for Transformers with Rated Frequency Equal to 50 Hz

Rated power kVA	level 1		level 2	
	Maximum load losses (in W)	Maximum no-load losses (in W)	Maximum load losses (in W)	Maximum no-load losses (in W)
≤ 50	1 700	200	1 500	180
100	2 050	280	1 800	252
160	2 900	400	2 600	360
250	3 800	520	3 400	468
400	5 500	750	4 500	675
630	7 600	1 100	7 100	990
800	8 000	1 300	8 000	1 170
1 000	9 000	1 550	9 000	1 395
1 250	11 000	1 800	11 000	1 620
1 600	13 000	2 200	13 000	1 980
2 000	16 000	2 600	16 000	2 340
2 500	19 000	3 100	19 000	2 790
3 150	22 000	3 800	22 000	3 420

NOTE:

In some countries, higher losses are allowed in regulations for transformers outside the scope of this table, for example with a wider tapping range, dual LV windings or higher voltage.

IEC 60076-20 Recommended performance parameters.

3.10 Rated Voltage ≤ 12 kV Short-Circuit Impedance 6%

U _m	S _R	P _K	P _K	P _O	L _{WA}	P _O	L _{WA}	P _O	L _{WA}
		A _K	B _K	A _O		B _O		C _O	
kV	kVA	W	W	W	dB(A)	W	dB(A)	W	dB(A)
12	100	1 800	2 000	260	51	330	51	440	59
	160	2 600	2 700	350	54	450	54	610	62
	250	3 400	3 500	500	57	610	57	820	65
	400	4 500	4 900	700	60	880	60	1 150	68
	630	7 100	7 300	1 000	62	1 150	62	1 500	70
	800	8 000	9 000	1 100	64	1 300	65	1 800	71
	1 000	9 000	10 000	1 300	65	1 500	67	2 100	73
	1 250	11 000	12 000	1 500	67	1 800	69	2 500	75
	1 600	13 000	14 500	1 800	68	2 200	71	2 800	76
	2 000	15 500	18 000	2 200	70	2 600	73	3 600	78
	2 500	18 500	21 000	2 600	71	3 200	75	4 300	81
3 150	22 000	26 000	3 150	74	3 800	77	5 300	83	

NOTE:

This European Standard also applies to transformers having Insulation System Temperature (IST) with temperature rise higher than IST of 180°C; According to EN 60076-11:2004, Table 2; in this case the load loss will be calculated with proper temperature correction factors for rated temperature rises, for load loss guaranty and impedance voltage temperature reference (see 3.8).

EN 50541-1:2011 Recommended performance parameters.

3.11 Rated Voltage 17,5 kV and 24 kV Impedance Voltage 6%

U _m	S _R	P _K	P _K	P _O	L _{WA}	P _O	L _{WA}	P _O	L _{WA}
		A _K	B _K	A _O		B _O		C _O	
kV	kVA	W	W	W	dB(A)	W	dB(A)	W	dB(A)
17,5 and 24	100	1 800	2 050	280	51	340	51	460	59
	160	2 600	2 900	400	54	480	54	650	62
	250	3 400	3 800	520	57	650	57	880	65
	400	4 500	5 500	750	60	940	60	1 200	68
	630	7 100	7 600	1 100	62	1 250	62	1 650	70
	800	8 000	9 400	1 300	64	1 500	64	2 000	72
	1 000	9 000	11 000	1 550	65	1 800	65	2 300	73
	1 250	11 000	13 000	1 800	67	2 100	67	2 800	75
	1 600	13 000	16 000	2 200	68	2 400	68	3 100	76
	2 000	16 000	18 000	2 600	70	3 000	70	4 000	78
	2 500	19 000	23 000	3 100	71	3 600	71	5 000	81
3 150	22 000	28 000	3 800	74	4 300	74	6 000	83	

NOTE:

This European Standard applies also to transformers having Insulation System Temperature (IST) with temperature rise higher than IST of 180°C; according to EN 60076-11:2004, Table 2; in this case the load loss will be calculated with proper temperature correction factors for rated temperature rises, for load loss guaranty and impedance voltage temperature reference (see 3.8).

EN 50541-1:2011 Recommended performance parameters.

3.12 Rated Voltage 36 kV Impedance Voltage 6%

U _m	S _R	P _K	P _K	P _K	P _O	L _{WA}	P _O	L _{WA}	P _O	L _{WA}
		A _K	B _K	C _K	A _O		B _O		C _O	
kV	kVA	W	W	W	W	dB(A)	W	dB(A)	W	dB(A)
36	160	2 500	2 700	2 900	850	57	900	62	960	66
	250	3 500	3 800	4 000	1 000	59	1 100	64	1 280	67
	400	5 000	5 400	5 700	1 200	61	1 300	65	1 650	69
	630	7 000	7 500	8 000	1 400	63	1 600	68	2 200	71
	800	8 400	9 000	9 600	1 650	64	1 900	69	2 700	72
	1 000	10 000	11 000	11 500	1 900	65	2 250	70	3 100	73
	1 250	12 000	13 000	14 000	2 200	67	2 600	72	3 600	75
	1 600	14 000	16 000	17 000	2 550	68	3 000	73	4 200	76
	2 000	17 000	18 500	21 000	3 000	72	3 500	74	5 000	78
	2 500	20 000	22 500	25 000	3 500	73	4 200	78	5 800	81
	3 150	25 000	27 500	30 000	4 100	76	5 000	81	6 700	83

NOTE:

This European Standard applies also to transformers having Insulation System Temperature (IST) with temperature rise higher than IST of 180°C; according to EN 60076-11:2004, Table 2; in this case the load loss will be calculated with proper temperature correction factors for rated temperature rises, for load loss guaranty and impedance voltage temperature reference (see 3.8).

EN 50541-1:2011 Recommended performance parameters.

3.13 Rated voltage 35 kV Dry-type Power Transformer(NLTC)

35 kV class 800 kVA to 25000 kVA on-load tap-changing power transformer														
rated capacity (kVA)	Voltage combination and tap range			Connection group number	no-load loss (kW)	Load loss at different insulation system temperatures (kW)			no-load current (%)	short circuit impedance (%)				
	high voltage (kV)	High voltage tap range (%)	low voltage (kV)			130°C(B) (100 °C)	155°C(F) (120 °C)	180°C(H) (145 °C)						
800	35	±2x2.5	3.15	3.15	2.25	8.87	9.4	10	0.95	6				
1 000					2.67	10.3	10.9	11.6	0.95					
1 250					3.13	12.1	12.9	13.8	0.85					
1 600					36	±5	6	6.3	3.69	14.6	15.4	16.5	0.85	7
2 000									4.23	17.2	18.2	19.5	0.75	
2 500									4.86	20.6	21.8	23.3	0.75	
3 150									6.03	23.1	24.5	26.2	0.7	
4 000					37	±5	10	10.5	7.02	27.7	29.4	31.5	0.7	8
5 000									8.37	32.9	34.9	37.4	0.6	
6 300									9.9	38.5	40.8	43.7	0.6	
8 000									11.3	43.4	46	49.3	0.5	
10 000	12.9	52.4	55.5	59.4					0.5					
12 500	38.5	±5	11	11	15.7	60.9	64.6	69.1	0.4	9				
16 000					19.3	71.7	76	81.3	0.4					
20 000					22.9	80.6	85.5	91.5	0.35					
25 000					27.1	95.3	101	108	0.35					
										10				

3 Technical Features

3.14 Rated voltage 35 kV Dry-type Power Transformer(OLTC)

35 kV class 2000 kVA to 25000 kVA on-load tap-changing power transformers													
rated capacity (kVA)	Voltage combination and tap range			Connection group number	no-load loss (kW)	Load loss at different insulation system temperatures (kW)			no-load current (%)	short circuit impedance (%)			
	high voltage (kV)	High voltage tap range(%)	low voltage (kV)			130°C(B) (100 °C)	155°C(F) (120 °C)	180°C(H) (145 °C)					
2 000	35	±4×2.5	6	Dyn11	4.5	17.9	19	20.3	0.75	7			
2 500					5.22	21.3	22.6	24.2	0.75				
3 150					6.3	10	Yd11	6.3	24	25.4	27.2	0.7	8
4 000								7.38	28.7	30.4	32.6	0.7	
5 000								8.73	34	36.1	38.6	0.6	
6 300								10.3	39.4	41.8	44.7	0.6	
8 000								11.8	44.8	47.5	50.8	0.5	
10 000								13.5	53.9	57.1	61.2	0.5	
12 500					11	10.5	Yd11	16.4	62.7	66.5	71.1	0.4	9
16 000								20.2	73.8	78.2	83.7	0.4	
20 000	23.8	83	88	94.2				0.35					
25 000	28.1	98.2	104	111				0.35					

3.15 Dimensions of Typical Ratings

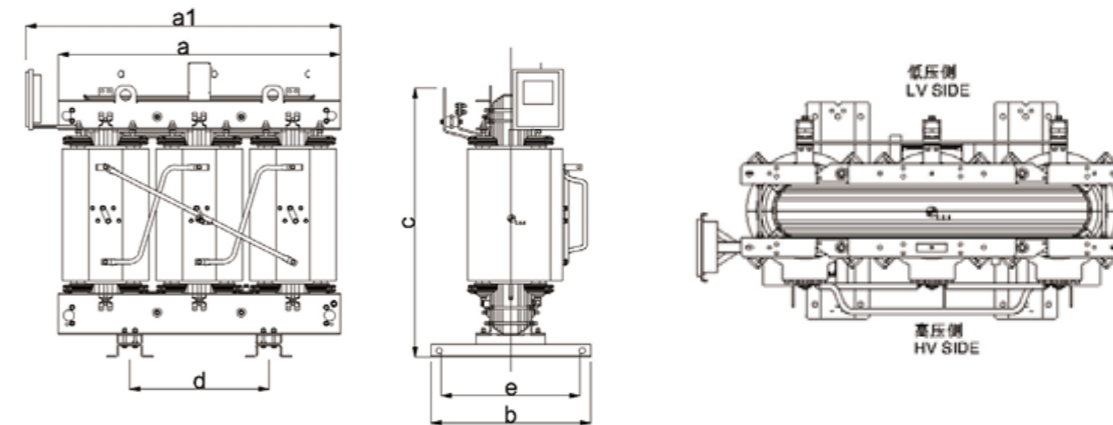

Mechanical data of 10 kV transformer					
Rated power kVA	Winding Material	Base Frame Q1xQ2 (mm)	Weight (kg)	Outline Dimension (Length x Width x Height) (mm)	Enclosure Dimension (IP20) (Length x Width x Height) (mm)
630	copper	670x660	2030	1540x870x1430	2000x1500x2200
800		670x660	2380	1590x880x1550	2000x1500x2200
1000		820x820	2740	1620x990x1570	2200x1650x2200
1250		820x820	3330	1710x990x1615	2200x1650x2200
1600		820x820	4070	1810x1010x1680	2200x1650x2200
2000		1070x1070	5130	1940x1280x1765	2500x1800x2400
2500		1070x1070	6070	2030x1280x1885	2500x1800x2400
630		Aluminum	670x660	1890	1580x990x1525
800	670x660		2170	1630x890x1570	2000x1500x2200
1000	820x820		2680	1720x995x1640	2200x1650x2200
1250	820x820		3040	1810x1005x1735	2200x1650x2200
1600	820x820		3810	1870x1015x1955	2200x1650x2200
2000	1070x1070		4440	2000x1280x2045	2500x1800x2400
2500	1070x1070		5510	2190x1280x2075	2500x1800x2400

Comments:

We reserve the right to make technical changes or modify the contents of this catalogue without prior notice.

3.15 Dimensions of Typical Ratings

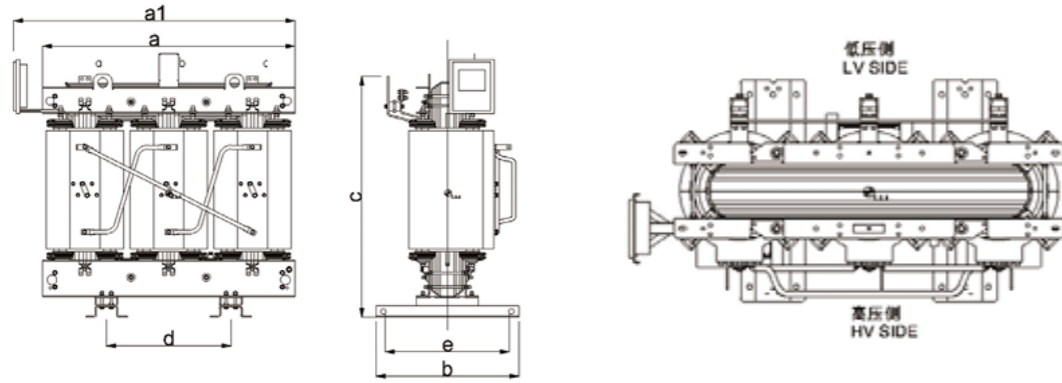

Mechanical data of 20 kV transformer					
Rated power kVA	Winding Material	Base Frame Q1xQ2 (mm)	Weight (kg)	Outline Dimension (Length x Width x Height) (mm)	Enclosure Dimension (IP20) (Length x Width x Height) (mm)
630	copper	670x660	2030	1540x870x1430	2000x1500x2200
800		670x660	2380	1590x880x1550	2000x1500x2200
1000		820x820	2740	1620x990x1570	2200x1650x2200
1250		820x820	3330	1710x990x1615	2200x1650x2200
1600		820x820	4070	1810x1010x1680	2200x1650x2200
2000		1070x1070	5130	1940x1280x1765	2500x1800x2400
2500		1070x1070	6070	2030x1280x1885	2500x1800x2400
630	Aluminum	670x660	1890	1580x990x1525	2000x1500x2200
800		670x660	2170	1630x890x1570	2000x1500x2200
1000		820x820	2680	1720x995x1640	2200x1650x2200
1250		820x820	3040	1810x1005x1735	2200x1650x2200
1600		820x820	3810	1870x1015x1955	2200x1650x2200
2000		1070x1070	4440	2000x1280x2045	2500x1800x2400
2500		1070x1070	5510	2190x1280x2075	2500x1800x2400

Comments:

We reserve the right to make technical changes or modify the contents of this catalogue without prior notice.

3.15 Dimensions of Typical Ratings

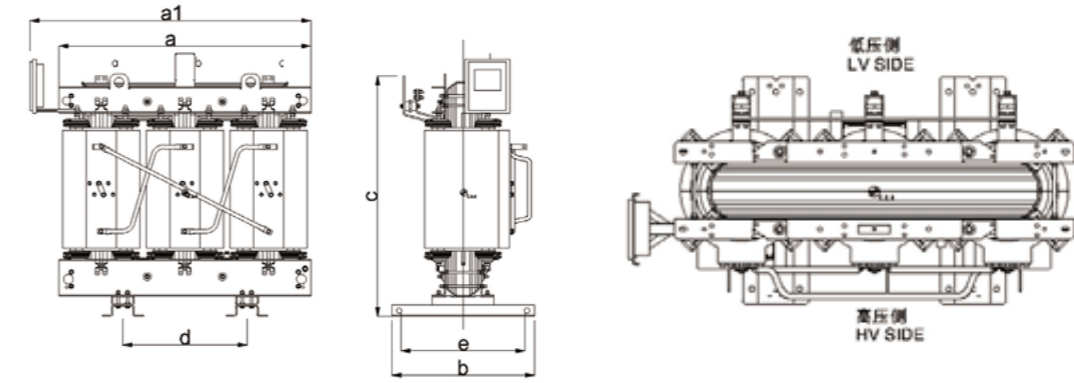

Mechanical data of 35 kV transformer					
Rated power kVA	Winding Material	Base Frame Q1xQ2 (mm)	Weight (kg)	Outline Dimension (Length x Width x Height) (mm)	Enclosure Dimension (IP20) (Length x Width x Height) (mm)
630	copper	670x660	2030	1540x870x1430	2000x1500x2200
800		670x660	2380	1590x880x1550	2000x1500x2200
1000		820x820	2740	1620x990x1570	2200x1650x2200
1250		820x820	3330	1710x990x1615	2200x1650x2200
1600		820x820	4070	1810x1010x1680	2200x1650x2200
2000		1070x1070	5130	1940x1280x1765	2500x1800x2400
2500		1070x1070	6070	2030x1280x1885	2500x1800x2400
630	Aluminum	670x660	1890	1580x990x1525	2000x1500x2200
800		670x660	2170	1630x890x1570	2000x1500x2200
1000		820x820	2680	1720x995x1640	2200x1650x2200
1250		820x820	3040	1810x1005x1735	2200x1650x2200
1600		820x820	3810	1870x1015x1955	2200x1650x2200
2000		1070x1070	4440	2000x1280x2045	2500x1800x2400
2500		1070x1070	5510	2190x1280x2075	2500x1800x2400

Comments:

We reserve the right to make technical changes or modify the contents of this catalogue without prior notice.

Specification of TGOOD Dry-type Transformer

Standard and Tech.Agreement		According to		
		GB 1094.11-2007	GB/T 10228-2015	IEC 60076-11
		GB 20052-2013	JB/T 3837-2016	GB/T 22072-2018
Client Name				
Project Name				
Type				
Quantity		Set		
Number of Phase		Phase		
Frequency		Hz		
Rating		kVA		
Voltage Ratio		kV		
Tapping On HV		%		
Cooling Method				
Highest System Voltage		kV		
Power Frequency Withstand Voltage		kV		
Rated Lightning Impulse Withstand Voltage		kV		
Vector Group				
No Load Loss		kW		
Load Loss		kW		
Short Circuit Impedance		%		
Noise Level		dB		
Winding Material		HV Winding		
Insulation Class		LV Winding		
Temperature Rise		k		
Partial Discharge		Pc		
Enclosure	Enclosure Protection Class			
	Terminal Incoming/Outgoing			
	Painting color			
	Material			
	Lockout switch for enclosure			
Thermometer	The output type of thermometer			
Special Test		Yes: (Please indicate)		
If any special requirements of the size or weight for location and transportation passage		Yes: (Please indicate)		
If the customer has a equipment number		Yes: (Please indicate)		
Environment Temperature		Min		Max
Altitude				
Packing Method				
Transportation				
Attached Documents	Quantity			
	Language			
The final destination of the goods				
Remarks:				

Certificates

